

ENERGY SAVER MANUFACTURED HOUSING STANDARD VENT AND DIRECT VENT MODELS

COMPLY WITH HUD STANDARDS FOR MANUFACTURED HOUSING INSTALLATION

- Meets the Federal Energy Efficiency Standards effective January 20, 2004, according to the National Appliance Energy Conservation Act (NAECA) of 1992.

FLAMABLE VAPOR IGNITION RESISTANT (FVIR) COMPLIANT

GAS CONTROL CONVERTIBLE FOR NATURAL AND PROPANE GAS

- For flexibility to meet the varying needs of Manufactured Housing installations.

SIDE-MOUNTED 3/4" COLD WATER INLET (30 & 40-GALLON MODELS)

- For ease of installation when cold water supply originates below the structure. Top-mounted 3/4" hot water outlet.

DIRECT VENT MODELS PACKAGED WITH BOTTOM INTAKE AIR VENT

- To draw all combustion make-up air from outside the structure.

OPTIONAL DUCTED AIR INLET KIT FOR DIRECT VENT MODELS

- For use when water heater is installed over a basement. Provision for horizontal air inlet ducting up to 30 feet, using Schedule 40 PVC pipe. Kit includes 45° rodent-proof termination cap and wall collars. Kit #9002986005 for 30 and 40-gallon models. Kit #9002987005 for 50-gallon models.

GREEN CHOICE® ECO-FRIENDLY GAS BURNER

- Patented design reduces NOx emissions by up to 33% and complies with less than 40 ng/j requirements for low NOx emissions.

GLASSLINED TANK

- For long-lasting protection against corrosion.

ANODE ROD

- Helps protect against corrosion and maximizes tank life.

CSA CERTIFIED AND ASME RATED T&P RELIEF VALVE

MAXIMUM HYDROSTATIC WORKING PRESSURE 150 PSI

DESIGN-CERTIFIED BY CSA INTERNATIONAL

6-YEAR LIMITED TANK WARRANTY, 2-YEAR LIMITED PARTS WARRANTY

- For complete information, consult written warranty or A. O. Smith.



Green Choice®
The Eco-Friendly Gas-Fired Burner



MODEL NUMBER	SERIES	FIRST HOUR RATING GALLONS	ENERGY FACTOR	GAL. CAP.	BTU INPUT PER HOUR NATURAL/PROPANE	RECOVERY 90°F RISE GALLONS PER HOUR	R VALUE	DIMENSIONS IN INCHES							APPROX. SHIPPING WEIGHT (LBS.)
								A	B	C	D	E	F	DRAFT HOOD OUTLET	
STANDARD ATMOSPHERIC VENT MODELS – See Figure 2															
FMV-30	200	62	0.61	30	35,500/32,000	36	8	61-1/2	58	16	13-1/4	14-1/4	51-3/4	3 or 4	125
FMV-40	200	60	0.59	40	35,500/32,000	34	8	61-3/4	58-1/4	20	13	14-1/4	57-3/4	3 or 4	150
DIRECT VENT MODELS – See Figure 1															
FMD-30	102	54	0.61	30	30,000	31	16	–	56	18	15-1/4	16-3/4	51-1/2	3-1/2	115
FMD-40	102	64	0.59	40	32,000	33	16	–	56-1/2	20	15-1/4	20-3/4	51	3-1/2	134
FMD-50	102	77	0.59	50	38,000	39	16	–	56-1/2	22	15-1/4	23-1/4	50-1/2	4-1/2	170

Approved Roof Jack Kits for Direct Vent Models

Direct Vent Manufactured Housing water heaters must be installed using one of these approved Roof Jack Kits, which must be ordered separately. "Min." and "Max." dimensions indicate kit adjustability for varying vent distances, as shown in drawing.

KIT NUMBER	MIN.	MAX.	SHIP. WEIGHT
9002964005	–	12"	10
9002965005	17"	32"	13
9002966005	32"	60"	27
9002967005	49"	96"	22

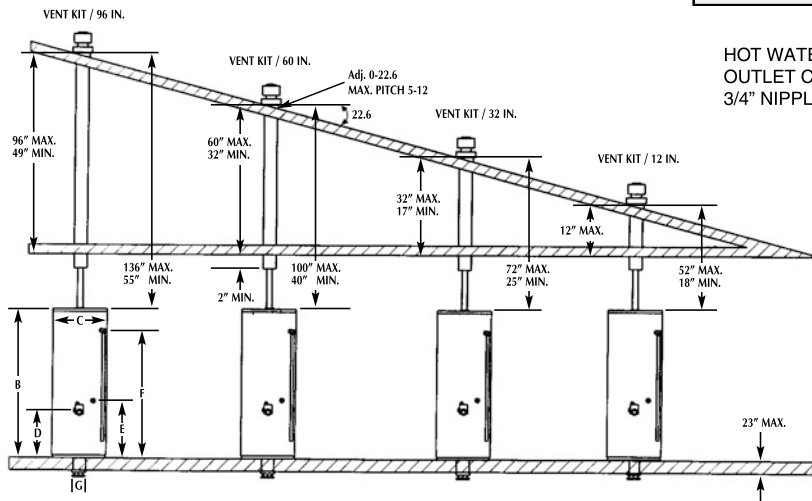

Direct Vent Models
FIGURE 1

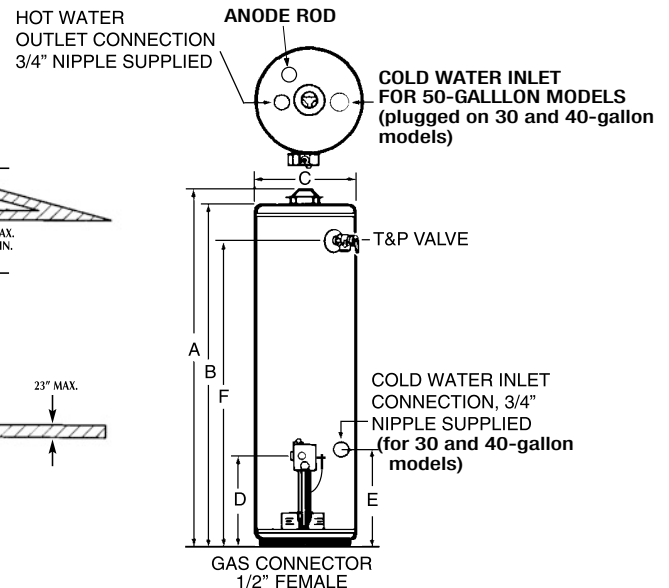

Standard Vent Models
FIGURE 2