



UP TO 82% EFFICIENT HOT WATER SUPPLY BOILERS

The Dura-Max® series offers excellent performance and low-profile design flexibility for both new construction and retrofit applications. A double-row, integral-finned copper tube heat exchanger provides exceptional heat transfer efficiency. Each unit features a small footprint with a built-in draft diverter for extra clearance to simplify installation. Reliable, quiet, drawer-mounted stainless steel burners resist corrosion, improve access for easy maintenance.

FEATURES

100% ALL NON-FERROUS HEAT EXCHANGER WATERWAYS

- All waterways 100% copper, brass or bronze
- Won't rust, resists thermal shock
- Heavy-duty bronze castings and copper heat exchange tubes
- Bronze removable return bends for easy access and inspection of individual tubes

GASKETLESS WET SECTION

- Unique "O"-ring design compresses to form water-tight seal positioned away from and outside the combustion chamber
- Isolated location offers optimum protection and years of service

DRAWER-MOUNTED, STAINLESS STEEL DURA-MAX® BURNERS

- Quiet operation and efficient, reliable design
- Protects against corrosion and condensation deterioration
- Easy slide-out burner tray simplifies cleaning and maintenance

COMPACT, LOW-PROFILE DESIGN

- Built-in draft diverter provides extra clearance in tight, retrofit installations
- Clean, compact jacket design for easy access and assembly
- Cool to touch and approved for combustible floors

INTERMITTENT ELECTRONIC IGNITION

- Eliminates standing pilot, saves energy
- Includes power ON/OFF switch

FACTORY-MOUNTED BRONZE-FITTED PUMP

- Ensures proper flow rates and efficient heat transfer
- Thermal Balancer Pump Delay Switch cycles pump, reduces standby heat loss

MAXIMUM HYDROSTATIC WORKING PRESSURE: 160 PSI

MEETS CURRENT EDITION ASHRAE/IESNA 90.1

FIVE-YEAR HEAT EXCHANGER LIMITED WARRANTY

- For complete information, consult written warranty or contact A. O. Smith

**MODELS
DW-720
through
DW-1810**



ASME

OTHER DURA-MAX® FEATURES

MANUAL RESET, HIGH LIMIT • ASME-RATED PRESSURE RELIEF VALVE • 125#
 • SAFETY FLOW • SWITCH • REDUNDANT GAS VALVE

DURA-MAX® OPTIONS

- CSD-1
- NEW YORK CODE
- CALIFORNIA CODE
- PANEL MOUNTED INLET/OUTLET DIAL
- THERMOMETERS AND PRESSURE GAUGE
- DUAL STAGE FIRING
- RIGHT HAND GAS AND/OR WATER CONNECTIONS
- CUPRO-NICKEL HEAT EXCHANGER
- SIDEWALL VENT KITS ALL-BRONZE PUMP
- HIGH VELOCITY HARD WATER PUMP
- LOW WATER CUTOFF

INPUT AND RECOVERY

MODEL NUMBER	BTU INPUT PER HOUR*	GPH OR LPH	RECOVERY - GALLONS OR LITRES PER HOUR AT DEGREE RISE		
			40°F	100°F	140°F
			22°C	56°C	78°C
DW-720	720,000	GPH	1767	707	505
		LPH	6690	2676	1911
DW-840	840,000	GPH	2062	825	589
		LPH	7805	3122	2230
DW-960	960,000	GPH	2356	943	673
		LPH	8920	3568	2548
DW-1080	1,080,000	GPH	2684	1073	767
		LPH	10,158	4063	2902
DW-1210	1,210,000	GPH	3007	1203	859
		LPH	11,381	4552	3252
DW-1350	1,350,000	GPH	3355	1342	958
		LPH	12,698	5079	3628
DW-1480	1,480,000	GPH	3588	1435	1025
		LPH	13,581	5432	3880
DW-1610	1,610,000	GPH	3903	1561	1115
		LPH	14,774	5910	4221
DW-1810	1,810,000	GPH	4388	1755	1254
		LPH	16,609	6644	4746

* Natural gas only
 Gas supply pressure: 13:8" w.c. maximum, 5.5" w.c. minimum
 Electrical requirements: 120 VAC, 15 Amps

MINIMUM CLEARANCES TO COMBUSTIBLES - ALL MODELS

	Inches	CM
TOP	12	30.5
WATERSIDE	18	45.7
BLANK SIDE	6	15.5
REAR	6	15.5
VENT	6	15.5
FRONT	Alcove	

STANDARD MODELS

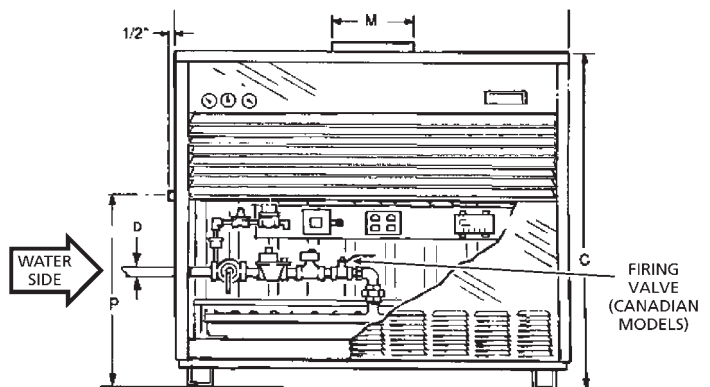
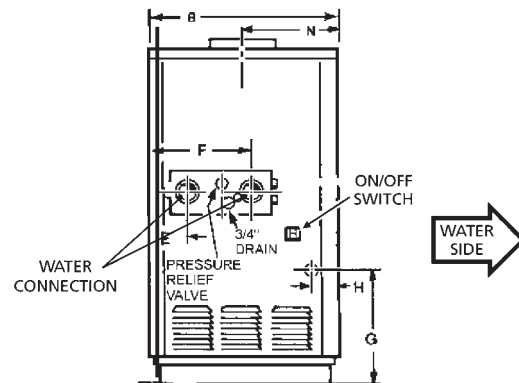



Domestic Hot Water Boilers

INPUT/OUTPUT, FLOW RATE (GALLONS AND LITRES PER MINUTE) AND PRESSURE DROP

MODEL NUMBER	BTU/HR. INPUT	BTU/HR. OUTPUT	20°F/11°C DELTA T				30°F/17°C DELTA T				40°F/22°C DELTA T			
			MAXIMUM FLOW		PRESSURE DROP		MAXIMUM FLOW		PRESSURE DROP		MAXIMUM FLOW		PRESSURE DROP	
			GPM	LPM	FEET	METERS	GPM	LPM	FEET	METERS				
DW-720	720,000	583,200	59	223	3.5	1.1	39	149	1.7	0.5	29	111	1.0	0.3
DW-840	840,000	680,400	69	260	4.8	1.5	46	173	2.1	0.6	34	130	1.5	0.5
DW-960	960,000	777,600	79	297	6.8	2.1	52	198	3.3	1.0	39	149	1.9	0.6
DW-1080	1,080,000	885,600	89	339	4.5	1.4	60	226	2.1	0.6	45	169	1.4	0.4
DW-1210	1,210,000	992,200	100	379	5.3	1.6	67	253	2.7	0.8	50	190	1.6	0.5
DW-1350	1,350,000	1,107,000	112	423	6.8	2.1	75	282	3.2	1.0	56	212	1.8	0.5
DW-1490	1,490,000	1,184,000	120	453	7.9	2.4	80	302	3.9	1.2	60	226	2.1	0.6
DW-1610	1,610,000	1,288,000	130	492	9.5	2.9	87	328	5.0	1.5	65	246	3.0	0.9
DW-1810	1,810,000	1,448,000	146	554	12.0	3.7	98	369	6.2	1.9	73	277	3.9	1.2

Pressure drop shown is loss through boiler only, and does not include any additional piping.

DIMENSIONS AND SHIPPING WEIGHTS

MODEL NUMBER	INCHES OR CM	DIMENSIONS												SHIPPING WEIGHT
		A	B	C	D	E	F	G	H	L	M	N	P	
DW-720	Inches	46-1/2	29-5/8	54-3/4	1-1/4	7-3/4	15-1/2	17-1/4	4-1/4	1	12	15-1/2	32-1/8	780 Lbs.
	CM	118.1	75.2	139.1	3.2	19.7	39.4	43.8	10.8	2.5	30.5	39.4	81.6	354 Kg
DW-840	Inches	52-1/5	29-5/8	54-3/4	1-1/4	7-3/4	15-1/2	17-1/4	4-1/4	1	14	16-1/2	31-1/8	950 Lbs.
	CM	132.6	75.2	139.1	3.2	19.7	39.4	43.8	10.8	2.5	35.6	41.9	79.1	431 Kg
DW-960	Inches	57-3/4	29-5/8	54-3/4	1-1/4	7-3/4	15-1/2	17-1/4	4-1/4	1	14	16-1/2	32-1/8	950 Lbs.
	CM	146.7	75.2	139.1	3.2	19.7	39.4	43.8	10.8	2.5	35.6	41.9	81.6	431 Kg
DW-1080	Inches	52-7/8	32-3/4	58	1-1/4	7-1/2	18-1/2	18-9/16	4	1-1/4	16	17-1/4	30-15/16	1000 Lbs.
	CM	134.3	83.2	147.3	3.2	19.1	47	47.1	10.2	3.2	40.6	43.8	78.6	454 Kg
DW-1210	Inches	58-1/2	32-3/4	58	1-1/2	7-1/2	18-1/2	18-9/16	4	1-1/4	16	17-1/4	30-15/16	1075 Lbs.
	CM	148.6	83.2	147.3	3.8	19.1	47	47.1	10.2	3.2	40.6	43.8	78.6	488 Kg
DW-1350	Inches	64-1/2	32-3/4	58	1-1/2	7-1/2	18-1/2	18-9/16	4	1-1/4	18	17 1/4	30-15/16	1100 Lbs.
	CM	163.8	83.2	147.3	3.8	19.1	47	47.1	10.2	3.2	45.7	45.7	78.6	499 Kg
DW-1480	Inches	69-1/2	34	60-1/2	1-1/2	7-1/2	18-1/2	19-1/8	4-1/2	1-1/4	18	13-3/4	31	1125 Lbs.
	CM	176.5	86.4	153.7	3.8	19.1	47	48.6	11.4	3.2	45.7	34.9	78.7	510 Kg
DW-1610	Inches	75	34	60-1/2	2	7-1/2	18-1/2	19-1/8	4-1/2	1-1/4	18	13-3/4	31	1150 Lbs.
	CM	190.5	86.4	153.7	5.1	19.1	47	48.6	11.4	3.2	45.7	34.9	78.7	522 Kg
DW-1810	Inches	82-1/2	34	60-1/2	2	7-1/2	18-1/2	19-1/8	4-1/2	1-1/4	20	13-3/4	31	1250 Lbs.
	CM	209.6	86.4	153.7	5.1	19.1	47	48.6	11.4	3.2	50.8	34.9	78.7	567 Kg

Water connections on DW-720 through DW-960: 2"

Water connections on DW-1080 through DW-1810: 2-1/2"



Domestic Hot Water Boilers

SUGGESTED SPECIFICATION

The hot water supply boiler(s) shall be A. O. Smith Dura-Max® model DW _____ with an input rating of _____ BTU/hr and a recovery rating of _____ BTU/hr at 100°F temperature rise. The boiler(s) shall be design-tested and certified to the ANSI Z21.13 standard, approved by CSA International and shall carry the ASME "H" Symbol. The wet section shall be design-registered in accordance with the requirements of the ASME Code and shall carry an appropriate National Board Number or Canadian Registration Number. All waterways shall be copper, brass or bronze. The heat exchanger shall be a two (2)-pass design incorporating integral-finned copper tubes. The double-row heat exchanger shall have staggered tubes. Cast bronze return bends shall be readily removable to permit visual inspection or cleaning without removing the entire wet section assembly. Silicone "O"-ring gaskets shall form a water-tight seal by compression and shall be isolated from the flue gases by 3/4" board-type ceramic fiber insulation. The heat exchanger assembly shall be hydrostatically tested to a pressure of 240 psi (1655 kPa) and shall have a maximum working pressure of 160 psi (1100 kPa). The combustion chamber shall be constructed of board-type ceramic fiber insulation rated to 2300°F (1260°C) which interlocks to form a gas-tight seal and shall be supported in a heavy-gauge corrugated steel frame. The external cabinet shall incorporate a built-in draft hood and shall be of baked enamel steel construction. It shall be suitable for installation on combustible flooring. The burners shall be a stainless steel stamped design and shall be mounted in a removable drawer assembly. The burner controls shall be 24 VAC and shall include slow-opening main gas valve for soft ignition, redundant safety shutoff gas valve, main and pilot pressure regulators, recycling intermittent pilot system with one-second shutdown in the event of pilot flame failure, automatic recycling high limit, manual reset ECO limit, main and pilot manual cocks and manual firing valve, and an ASME-rated pressure relief valve. The boiler shall be approved by Factory Mutual (FM). The boiler shall comply with current edition ASHRAE/IESNA 90.1. Optional: Factory-installed, dial-type temperature and pressure gauges shall be mounted on the front of the cabinet.