

CYCLONE® Xi

MODELS BTX AND BTXL 100

96% THERMAL EFFICIENT POWER DIRECT VENT MODELS.

The Cyclone® Xi is a light-duty, power direct vent, fully condensing commercial gas water heater with an internal helical heat exchanger. This helical heat exchanger helps Cyclone® Xi achieve 96% thermal efficiency and deliver outstanding hot water output.

ADVANCED ELECTRONIC CONTROL

- Large LCD display.
- Temperature control up to 181°F.
- Advanced diagnostics.

ENERGY STAR® QUALIFIED

HELICAL INTERNAL HEAT EXCHANGER

- Spiral heat exchanger keeps hot combustion gases in the tank longer to lengthen the heat transfer cycle.
- Positioned in the center of the tank for more even heat distribution.
- Operates at 96% thermal efficiency, which saves money on operating costs compared to a standard 80% efficient gas water heater.

POWER DIRECT VENT DESIGN

- Combined vertical and horizontal runs terminating through the roof or an outside wall. Vents using PVC, CPVC or polypropylene piping. Canadian installations require ULC S636 approved pipe for venting.
- 2" pipe, vents up to 45 equivalent feet.
- 3" pipe, vents up to 125 equivalent feet.

CONDENSING DESIGN

- 96% efficient condensing design.
- Equipped with condensate drain tee.

SIDE-MOUNTED HOT AND COLD RECIRCULATING TAPS

- Allows Cyclone® Xi to be installed as part of combination space heating/water heating applications.

COREGARD™ ANODE ROD

- Our anode rods have a stainless steel core that extends the life of the anode rod allowing superior tank protection far longer than standard anode rods.

BLUE DIAMOND® GLASS COATING

- Provides superior corrosion resistance compared to industry-standard glasslining.

TOP FIRED ULTRA-LOW NOx GAS BURNER

- Enhanced Ultra-low NOx burner complies with SCAQMD Rule 1146.2 and other Air Quality Management Districts with similar requirements for NOx emissions of less than 14 ng/J or 20 ppm.

AVAILABLE IN NATURAL GAS OR PROPANE

MAXIMUM HYDROSTATIC WORKING PRESSURE: 150 PSI

STANDARDS AND CERTIFICATIONS

- Design-certified by CSA International according to ANSI Z21.10.3 - CSA 4.3 Standards.
- These models meet the thermal efficiency and standby loss requirements of the U.S. Department of Energy and current edition ASHRAE/IES 90.1.
- CSA certified and ASME rated T&P relief valve.
- Approved for Canada.

3-YEAR LIMITED TANK AND 1 YEAR LIMITED PARTS WARRANTY

- For complete warranty information, consult written warranty or go to hotwater.com.



BTXL 100

BTX 100



DIMENSIONS FOR BTX-100

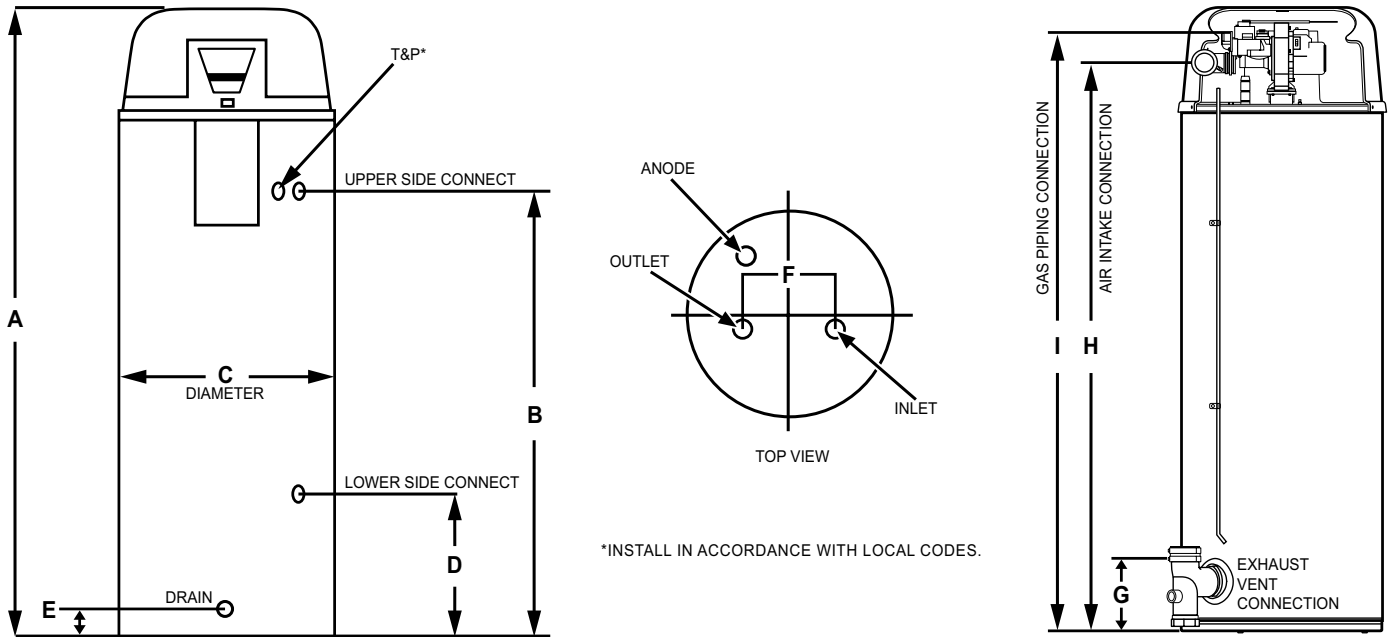

ROUGH-IN DIMENSIONS

| Model Number | Approximate Capacity | | Units | A | B | C | D | E | F | G | H | I |
|--------------|----------------------|--------|--------|-------|--------|-------|-------|------|-------|-------|--------|-------|
| | U.S. Gals. | Liters | | | | | | | | | | |
| BTX-100 | 50 | 189 | Inches | 66.75 | 49.25 | 22 | 15.75 | 3 | 8 | 8 | 62 | 65 |
| | | | cm | 169.5 | 125.09 | 55.88 | 40 | 7.62 | 20.32 | 20.32 | 157.48 | 165.1 |

Specify when ordering propane (LP) gas.

Standard model certified from sea level to 10,100 ft. elevation.

Optional Concentric Vent Kit (100111100) and Condensate Neutralization Kit (100112380).

Top Inlet and Outlet: 3/4" NPT

Side Inlet and Outlet: 3/4" NPT

Gas Inlet: 1/2" NPT

Condensate drain outlet: 1/2" NPT

Electrical Characteristics: 120V 60Hz <5 amps

The manifold pressure is factory set and is not adjustable. A negative pressure will be seen with just the blower running without the Gas Control Valve open.

All models - Maximum Supply Pressure: 14 inches W.C. (3.48kPa)

Minimum Supply Pressure for Natural Gas: 3.50" (.87kPa)

Minimum Supply Pressure for Propane Gas: 8.00" (1.99kPa)

Minimum pressure must be maintained under both load and no load (dynamic and static) conditions.

DIMENSIONS FOR BTXL-100

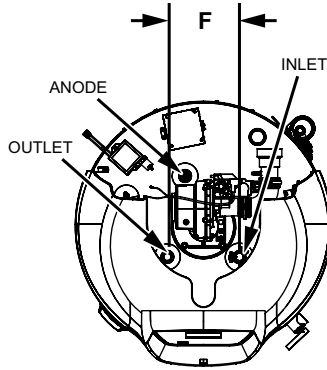
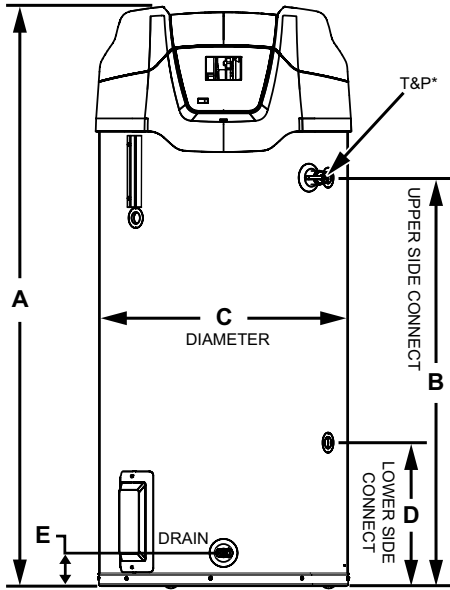

*INSTALL IN ACCORDANCE WITH LOCAL CODES.

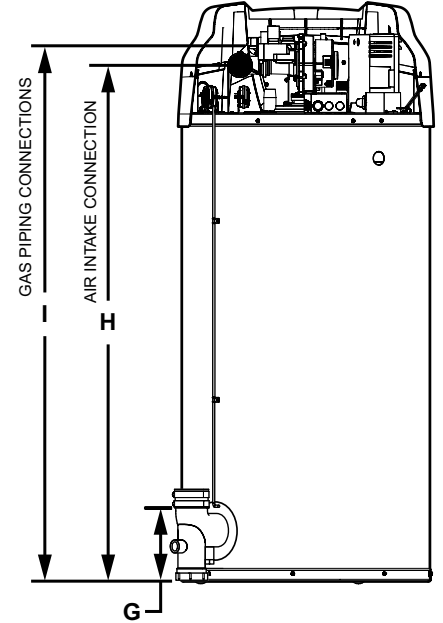

ROUGH-IN DIMENSIONS

| Model Number | Approximate Capacity | | Units | A | B | C | D | E | F | G | H | I |
|--------------|----------------------|--------|--------|-------|-------|-------|------|------|-------|------|-------|-------|
| | U.S. Gals. | Liters | | | | | | | | | | |
| BTXL-100 | 75 | 284 | Inches | 65.25 | 45.64 | 27.75 | 16 | 3.71 | 8 | 7.93 | 57.36 | 58.98 |
| | | | cm | 165.7 | 115.9 | 70.5 | 40.6 | 9.4 | 20.32 | 20.1 | 145.7 | 149.8 |

Specify when ordering propane (LP) gas.

Standard model certified from sea level to 10,100 ft. elevation.

Optional Concentric Vent Kit (100111100) and Condensate Neutralization Kit (100112380).

Top Inlet and Outlet: 1" NPT

Side Inlet and Outlet: 1" NPT

Gas Inlet: 1/2" NPT

Condensate drain outlet: 1/2" NPT

Electrical Characteristics: 120V 60Hz <5 amps

The manifold pressure is factory set and is not adjustable. A negative pressure will be seen with just the blower running without the Gas Control Valve open.

All models - Maximum Supply Pressure: 14 inches W.C. (3.48kPa)

Minimum Supply Pressure for Natural Gas: 3.50" (.87kPa)

Minimum Supply Pressure for Propane Gas: 8.00" (1.99kPa)

Minimum pressure must be maintained under both load and no load (dynamic and static) conditions.



Commercial Gas Water Heater

RECOVERY CAPACITIES - BTX AND BTXL

| Input | | Recovery Capacities | | | | | | | | | | | | | |
|-----------------|-------------|---------------------|------|------|-----|-----|-----|-----|-----|-----|-----|-----|-----|-----|-----|
| Rating (Btu/hr) | Rating (Kw) | Temp Rise | F | 30 | 40 | 50 | 60 | 70 | 80 | 90 | 100 | 110 | 120 | 130 | 140 |
| | | | C | 17 | 22 | 28 | 33 | 39 | 44 | 50 | 56 | 61 | 67 | 72 | 78 |
| 100,000 | 29.3 | GPH | 387 | 291 | 233 | 194 | 166 | 145 | 129 | 115 | 106 | 97 | 90 | 83 | |
| | | LPH | 1465 | 1102 | 882 | 734 | 628 | 549 | 488 | 439 | 401 | 367 | 341 | 314 | |

MAXIMUM VENTING DISTANCE - BTX AND BTXL

| Number of 90° Elbows | 2" Maximum Pipe-ft. (m) | 3" Maximum Pipe-ft. (m) |
|----------------------|-------------------------|-------------------------|
| 1 | 40 (12.19) | 120 (36.57) |
| 2 | 35 (10.66) | 115 (35.05) |
| 3 | 30 (9.14) | 110 (33.52) |
| 4 | 25 (7.62) | 105 (32) |
| 5 | 20 (6.09) | 100 (30.48) |
| 6 | 15 (4.57) | 95 (28.95) |

Note: See the Instruction Manual for the most current and detailed venting information.

SUGGESTED SPECIFICATION

(Natural or Propane) gas water heater(s) shall be A. O. Smith Cyclone Xi model with 96% thermal efficiency with storage capacity _____; an input rating of 100,000 BTUs per hour, a recovery rating of 116 gallons per hour at 100°F rise and a maximum hydrostatic working pressure of 150 psi. Water heater(s) shall be of power direct vent design, using 2" or 3" PVC, CPVC, or polypropylene pipe for horizontal and/or vertical vent runs. Water heater(s) shall have: 1: Steel tank construction with seamless glass lining and a spiral-shaped heat exchanger placed entirely inside the tank, which shall be glasslined on the flue gas side to protect against acidic condensate. 2: Advanced electronic control w/ LCD display and actual diagnostic. 3: A 3-year limited warranty against tank leaks. Water heater(s) shall meet the thermal efficiency and standby loss requirements of the U.S. Department of Energy and current edition of ASHRAE/IES 90.1 and be design-certified by CSA International according to ANSI Z21.10.3-CSA 4.3 standards governing storage tank water heaters.

For Technical Information, call 800-527-1953. A. O. Smith Corporation reserves the right to make product changes or improvements without prior notice.