

COMMERCIAL GAS WATER HEATERS



25589 Highway 1
McBee, SC 29101



**MODELS: XWH
1000, 1300, 1700
2000, 2600, 3400
SERIES 100/101**

**INSTALLATION - OPERATION -
MAINTENANCE - LIMITED WARRANTY**

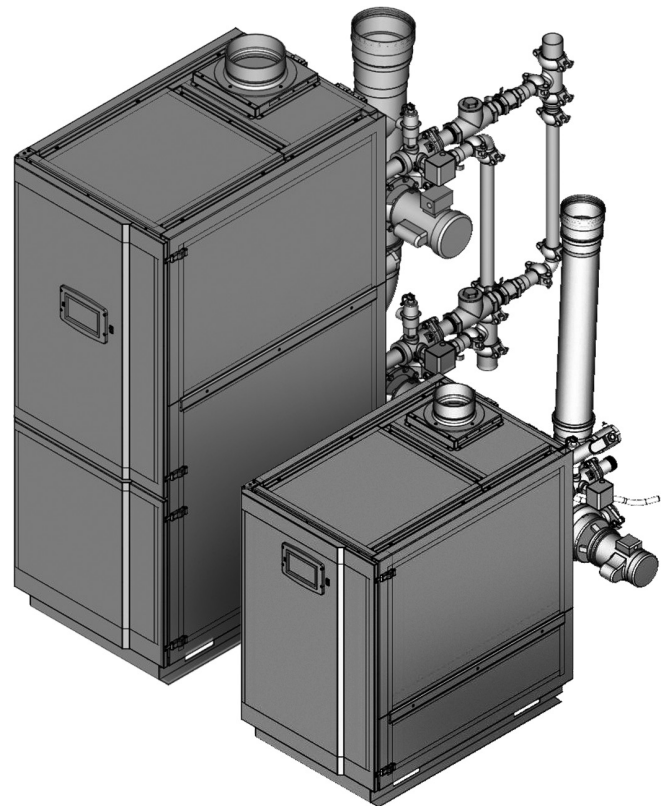

WARNING: If the information in these instructions is not followed exactly, a fire or explosion may result causing property damage, personal injury or death.

- Do not store or use gasoline or other flammable vapors and liquids in the vicinity of this or any other appliance.
- **WHAT TO DO IF YOU SMELL GAS:**
 - Do not try to light any appliance.
 - Do not touch any electrical switch; do not use any phone in your building.
 - Immediately call your gas supplier from a neighbor's phone. Follow the gas supplier's instructions.
 - If you cannot reach your gas supplier, call the fire department.
- Installation and service must be performed by a qualified installer, service agency or the gas supplier.

Thank you for buying this energy efficient water heater.
We appreciate your confidence in our products.



⚠ WARNING

Read and understand this manual and all Warnings and Cautions within before installing and using this appliance.

Place these instructions adjacent to water heater and notify owner to keep for future reference.





TABLE OF CONTENTS

TABLE OF CONTENTS.....	2
SAFE INSTALLATION, USE AND SERVICE.....	3
GENERAL SAFETY.....	4
INTRODUCTION.....	5
Model Identification.....	5
Abbreviations Used.....	5
Qualifications.....	5
DIMENSIONS AND CAPACITY DATA.....	6
FEATURES AND COMPONENTS.....	10
Component Description.....	12
CONTROL COMPONENTS.....	13
INSTALLATION CONSIDERATIONS.....	15
GENERAL REQUIREMENTS.....	20
Location.....	20
Fresh Air Openings For Confined Spaces.....	22
VENTING.....	24
Venting Supports.....	27
CONDENSATE DISPOSAL.....	37
GAS SUPPLY CONNECTIONS.....	38
START UP AND OPERATIONS.....	40
LIGHTING AND OPERATING INSTRUCTIONS.....	42
CONTROL SYSTEM.....	45
Burner Control System.....	45
Burner Control Operation.....	46
General Operational Sequence.....	47
Local Operator Interface: Display System.....	49
Installation Instructions (S7999D OI Display).....	49
Starting Up The S7999D OI Display.....	50
Page Navigation.....	50
TROUBLESHOOTING.....	60
MAINTENANCE PROCEDURES.....	75
Maintenance Schedules.....	75
General Maintenance.....	75
Burner Maintenance.....	76
Venting Maintenance.....	77
Heat exchanger Maintenance.....	77
Handling Ceramic Fiber Materials.....	78
Replacement Parts.....	78
PIPING DIAGRAMS.....	79
NOTES.....	81
NOTES.....	82
LIMITED WARRANTY.....	83

SAFE INSTALLATION, USE AND SERVICE

The proper installation, use and servicing of this water heater is extremely important to your safety and the safety of others. Many safety-related messages and instructions have been provided in this manual and on your water heater to warn you and others of a potential injury hazard. Read and obey all safety messages and instructions throughout this manual. It is very important that the meaning of each safety message is understood by you and others who install, use, or service this water heater.

	<p>This is the safety alert symbol. It is used to alert you to potential personal injury hazards. Obey all safety messages that follow this symbol to avoid possible injury or death.</p>
---	---

	<p>DANGER indicates an imminently hazardous situation which, if not avoided, will result in injury or death.</p>
	<p>WARNING indicates a potentially hazardous situation which, if not avoided, could result in injury or death.</p>
	<p>CAUTION indicates a potentially hazardous situation which, if not avoided, could result in minor or moderate injury.</p>
	<p>CAUTION used without the safety alert symbol indicates a potentially hazardous situation which, if not avoided, could result in property damage.</p>

All safety messages will generally tell you about the type of hazard, what can happen if you do not follow the safety message, and how to avoid the risk of injury.

The California Safe Drinking Water and Toxic Enforcement Act requires the Governor of California to publish a list of substances known to the State of California to cause cancer, birth defects, or other reproductive harm, and requires businesses to warn of potential exposure to such substances.

This product contains a chemical known to the State of California to cause cancer, birth defects, or other reproductive harm. This water heater can cause low level exposure to some of the substances listed in the Act.

IMPORTANT DEFINITIONS

Gas Supplier: The Natural Gas or Propane Utility or service who supplies gas for utilization by the gas burning appliances within this application. The gas supplier typically has responsibility for the inspection and code approval of gas piping up to and including the Natural Gas meter or Propane storage tank of a building. Many gas suppliers also offer service and inspection of appliances within the building.

APPROVALS

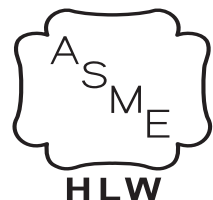

GENERAL SAFETY

GROUNDING INSTRUCTIONS

This water heater must be grounded in accordance with the National Electrical Code, Canadian Electrical Code and/or local codes. Water heater is polarity sensitive; correct wiring is imperative for proper operation.

This water heater must be connected to a grounded metal, permanent wiring system, or an equipment grounding conductor must be run with the circuit conductors and connected to the equipment grounding terminal or lead on the water heater.

INLET WATER CONSIDERATIONS

Circulating water through the water heater and to the remote storage tank is accomplished by a pump.

CORRECT GAS

Make sure the gas on which the water heater will operate is the same as that specified on the water heater rating plate. Do not install the water heater if equipped for a different type of gas; consult your supplier.

PRECAUTIONS

If the unit is exposed to the following, do not operate until all corrective steps have been made by a qualified service agent:

1. Exposure to fire.
2. If damaged.
3. Firing without water.
4. Sooting.

If the water heater has been exposed to flooding, it must be replaced.

LIQUEFIED PETROLEUM GAS MODELS

Water heaters for propane or liquefied petroleum gas (LPG) are different from natural gas models. A natural gas water heater will not function safely on LP gas and no attempt should be made to convert a water heater from natural gas to LP gas.

LP gas must be used with great caution. It is highly explosive and heavier than air. It collects first in the low areas making its odor difficult to detect at nose level. If LP gas is present or even suspected, do not attempt to find the cause yourself. Leave the building, leaving doors open to ventilate, then call your gas supplier or service agent. Keep area clear until a service call has been made.

At times you may not be able to smell an LP gas leak. One cause is odor fade, which is a loss of the chemical odorant that gives LP gas its distinctive smell. Another cause can be your physical condition, such as having a cold or diminishing sense of smell with age. For these reasons, the use of a propane gas detector is recommended.

If you experience an out of gas situation, do not try to relight appliances yourself. Call your local service agent. Only trained LP professionals should conduct the required safety checks in accordance with industry standards.

HIGH ALTITUDE INSTALLATIONS

WARNING

Breathing Hazard - Carbon Monoxide Gas



- Special consideration must be taken with Propane installations above 2000 feet (610 m).
- Please contact an A.O. Smith qualified service technician to obtain the proper setup and instructions before lighting.
- Failure to implement the proper setup will result in improper and inefficient operation of the appliance resulting in production of increased levels of carbon monoxide gas in excess of the safe limits which could result in serious personal injury or death.

Breathing carbon monoxide can cause brain damage or death.
Always read and understand instruction manual.

Rated inputs are suitable up to 2000 feet (610 m) elevation for Propane and 10,100 feet (3079 m) for Natural gas. Consult the factory for Propane installation at altitudes over 2000 feet (610 m).

FIELD INSTALLED COMPONENTS

When installing the water heater, the following components must be installed:

- Circulating Pump
- Remote Temperature Tank Sensor (Supplied with water heater)
- Storage Tank (Temperature & Pressure Relief Valve)

INTRODUCTION

This Instruction Manual covers models XWH 1000, 1300, 1700, 2000, 2600, 3400 - Series 100/101. The instructions and illustrations contained in this Instruction manual will provide you with troubleshooting procedures to diagnose and repair common problems and verify proper operation.

MODEL IDENTIFICATION

Check the rating plate affixed to the water heater. The following information describes the model number structure:

SERIES-100/101 DESIGNATION:

- XP = Extreme Performance

MODEL (APPLICATION):

- XWH = Automatic Circulating Water Heater

SIZE:

- 1000 = 920,000 Btu/hr input
- 1300 = 1,300,000 Btu/hr input
- 1700 = 1,700,000 Btu/hr input
- 2000 = 1,999,900 Btu/hr input
- 2600 = 2,600,000 Btu/hr input
- 3400 = 3,400,000 Btu/hr input

FUEL:

N = Natural gas

P = Propane

ABBREVIATIONS USED

Abbreviations found in this Instruction Manual include :

- ANSI - American National Standards Institute
- ASME - American Society of Mechanical Engineers
- NEC - National Electrical Code
- NFPA - National Fire Protection Association
- UL - Underwriters Laboratory
- CSA - Canadian Standards Association
- AHRI - Air-Conditioning, Heating and Refrigeration Institute

QUALIFICATIONS

QUALIFIED INSTALLER OR SERVICE AGENCY

Installation and service of this water heater requires ability equivalent to that of a Qualified Agency, as defined by ANSI below. In the field involved. Installation skills such as plumbing, air supply, venting, gas supply and electrical supply are required in addition to electrical testing skills when performing service.

ANSI Z21.13 - CSA 4.9: "Qualified Agency" - "Any individual, firm, corporation or company that either in person or through a representative is engaged in and is responsible for (a) the installation, testing or replacement of gas piping or (b) the connection, installation, testing, repair or servicing of appliances and equipment; that is experienced in such work; that is familiar with all precautions required; and that has complied with all the requirements of the authority having jurisdiction."

If you are not qualified (as defined by ANSI above) and licensed or certified as required by the authority having jurisdiction to perform a given task do not attempt to perform any of the procedures described in this manual. If you do not understand the instructions given in this manual do not attempt to perform any procedures outlined in this manual.

This product requires a formal Start-Up by an authorized service/start-up provider that has been approved by the manufacturer for this specific product. Call 1-800-527-1953 to locate the nearest authorized start-up provider and arrange a factory start-up. Please provide as much notice as possible, preferably 2 weeks. Please have the model and serial number ready when you call. This start-up is required to activate the warranty and ensure safe, efficient operation.

Warranty on this product is limited and could be void in the event the unit is not installed per the instructions in this manual and/or not started up by an authorized factory trained service/start-up provider.

DIMENSIONS AND CAPACITY DATA

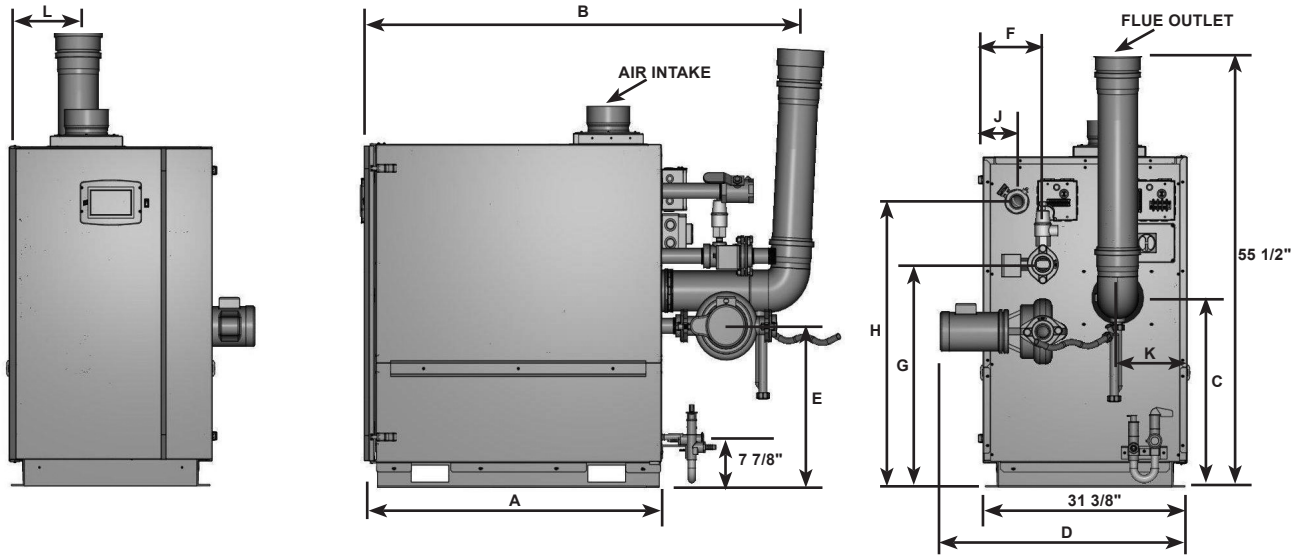

FIGURE 1. SINGLE HEAT EXCHANGER WATER HEATER

TABLE 1. ROUGH IN DIMENSIONS (SINGLE)

Models	XB-1000		XB-1300		XB-1700	
	inches	mm	inches	mm	inches	mm
Flue Outlet Diameter	6	152	8	152	8	203
Air Intake Diameter	6	152	6	152	8	203
Water Inlet	2 inch NPT				2 1/2 inch NPT	
Water Outlet	2 inch NPT				2 1/2 inch NPT	
Gas Inlet	2 inch NPT				2 inch NPT	
A	47	1199	49	1245	57	1448
B	67	1702	68	1727	76	1930
C	29	737	29	737	29	737
D	37	940	38	965	37	940
E	23	584	23	584	24	610
F	9	229	9	229	9	229
G	34	864	34	864	34	864
H	44	1118	45	1143	45	1143
J	6	152	6	152	6	152
K	11	279	11	279	11	279
L	12	305	11	279	12	305

TABLE 2. OPERATING CHARACTERISTICS

Models (XB)	Manifold Pressure			Maximum Supply Pressure		Minimum Supply Pressure		
	Type of Gas	Inches W.C.	kPa	Inches W.C.	kPa	Inches W.C.	kPa	
1000, 1300, 1700 2000, 2600, 3400	Natural	Min Fire	-0.2 to -0.3	-0.05 to -0.07	14.0	3.49	4.0	1.0
		Max Fire	-3.0 to -3.9	-0.75 to -0.97				
	Propane	Min Fire	-0.1 to -0.3	-0.025 to -0.07	14.0	3.49	4.0	1.0
		Max Fire	-3.6 to -4.9	-0.90 to -1.22				

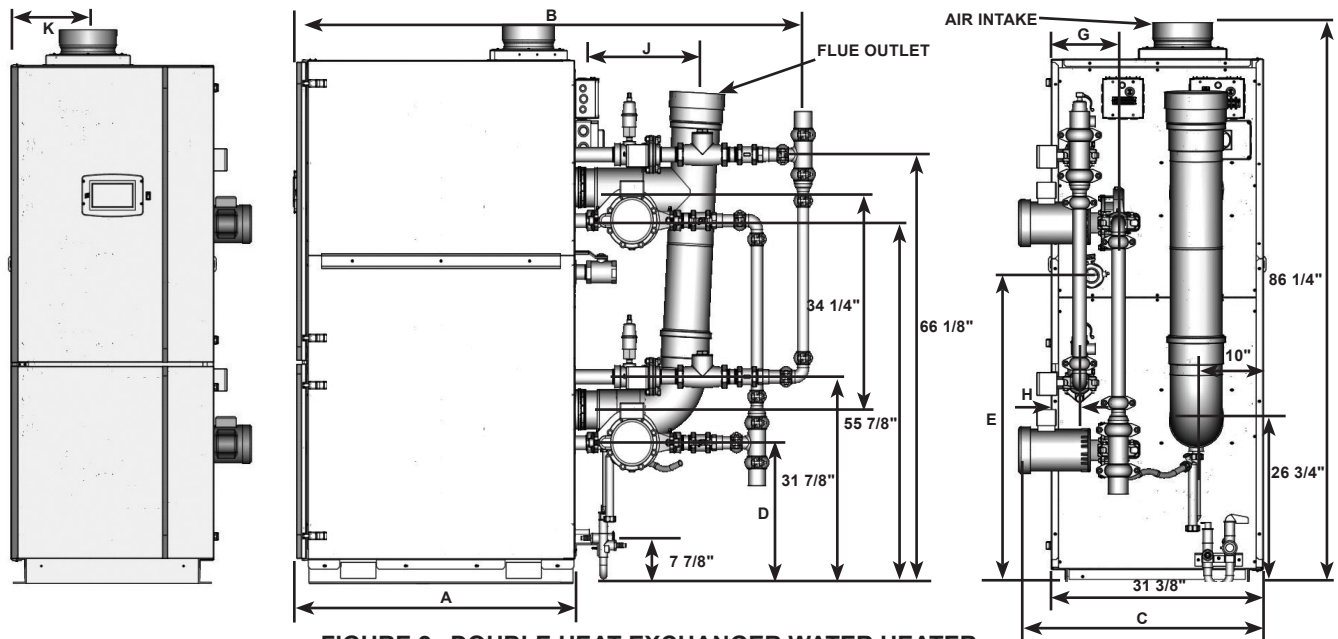

FIGURE 2. DOUBLE HEAT EXCHANGER WATER HEATER

TABLE 3. ROUGH IN DIMENSIONS (DOUBLE)

Models	XB-2000		XB-2600		XB-3400	
	inches	mm	inches	mm	inches	mm
Flue Outlet Diameter	8	203	8	203	10	254
Air Intake Diameter	8	203	8	203	10	254
Water Inlet	3 inch NPT				4 inch NPT	
Water Outlet	3 inch NPT				4 inch NPT	
Gas Inlet	2 inch NPT				3 inch NPT	
A	47	1194	49	1245	57	1448
B	78	1981	80	2032	91	2311
C	36	914	37	940	37	940
D	22	559	22	559	22	559
E	40	1016	41	1041	41	1041
F	7	178	6	152	6	152
G	10	254	10	254	10	254
H	4	102	4	102	4	102
J	20	508	19	483	19	483
K	12	305	12	305	13	330

TABLE 4. RECOVERY CAPACITIES

Models (XWH)	Input Rating (Btu/hr)	Water Flow	Temperature Rise - ΔT °F (°C)							
			40 (22)	60 (33)	70 (39)	80 (44)	90 (50)	100 (56)	120 (67)	140 (78)
1000	920,000	GPH	2,662	1,775	1,521	1,331	1,183	1,065	887	761
		LPH	10,078	6,719	5,759	5,039	4,479	4,031	3,359	2,880
1300	1,300,000	GPH	3,742	2,495	2,139	1,871	1,663	1,497	1,247	1,069
		LPH	14,167	9,444	8,095	7,083	6,296	5,667	4,722	4,048
1700	1,700,000	GPH	4,904	3,269	2,802	2,452	2,180	1,962	1,635	1,401
		LPH	18,565	12,376	10,608	9,282	8,251	7,426	6,188	5,304
2000	1,999,900	GPH	5,794	3,862	3,311	2,897	2,575	2,317	1,931	1,655
		LPH	21,931	14,621	12,532	10,966	9,747	8,773	7,310	6,266
2600	2,600,000	GPH	7,501	5,000	4,286	3,750	3,334	3,000	2,500	2,143
		LPH	28,393	18,929	16,225	14,196	12,619	11,357	9,464	8,112
3400	3,400,000	GPH	9,891	6,594	5,652	4,945	4,396	3,956	3,297	2,826
		LPH	37,441	24,961	21,395	18,721	16,641	14,976	12,480	10,697

ELECTRICAL REQUIREMENTS

TABLE 5. ELECTRICAL REQUIREMENTS

MODELS (XWH)	SUPPLY VOLTAGE (VOLTS)	FREQUENCY (HZ)	CURRENT (AMPS)	ELECTRICAL NOTES
1000	120	60	30	A dedicated, single phase, 30 amp circuit breaker with a grounded neutral should be provided to supply power to the water heater.
1300	120	60	30	
1700	120	60	30	
2000	120	60	60	A dedicated, single phase, 60 amp circuit breaker with a grounded neutral should be provided to supply power to the water heater.
2600	120	60	60	
3400	120	60	60	

FLOW, HEAD AND TEMPERATURE RISE

TABLE 6. FLOW, HEAD AND TEMPERATURE RISE

Models (XWH)	Input (Btu/hr)	Water Flow	Temperature Rise - ΔT °F			Flow Rate	
			20	30	40	Maximum	Minimum
1000	920,000	GPM	86	56	43	86	43
		LPM	325	211	162	325	162
		ΔP FT	26	12	7	26	7
		ΔP M	7.9	3.7	2.1	7.9	2.1
1300	1,300,000	GPM	120	80	60	120	60
		LPM	453	302	226	453	226
		ΔP FT	32.5	15	8	32.5	8
		ΔP M	9.9	4.6	2.4	9.9	2.4
1700	1,700,000	GPM	156	104	78	156	78
		LPM	592	395	296	592	296
		ΔP FT	35	14	8	35	8
		ΔP M	10.7	4.3	2.4	10.7	2.4
2000	1,999,900	GPM	184	123	92	184	92
		LPM	696	464	348	696	348
		ΔP FT	26	12	7	26	7
		ΔP M	7.9	3.7	2.1	7.9	2.1
2600	2,600,000	GPM	239	159	120	239	120
		LPM	905	604	453	905	453
		ΔP FT	32.5	15	8	32.5	8
		ΔP M	9.9	4.6	2.4	9.9	2.4
3400	3,400,000	GPM	313	209	156	313	156
		LPM	1184	789	592	1184	592
		ΔP FT	35	14	8	35	8
		ΔP M	10.7	4.3	2.4	10.7	2.4

NOTE: Head Loss shown is through the water heater only and allows for no additional piping.

FEATURES AND COMPONENTS

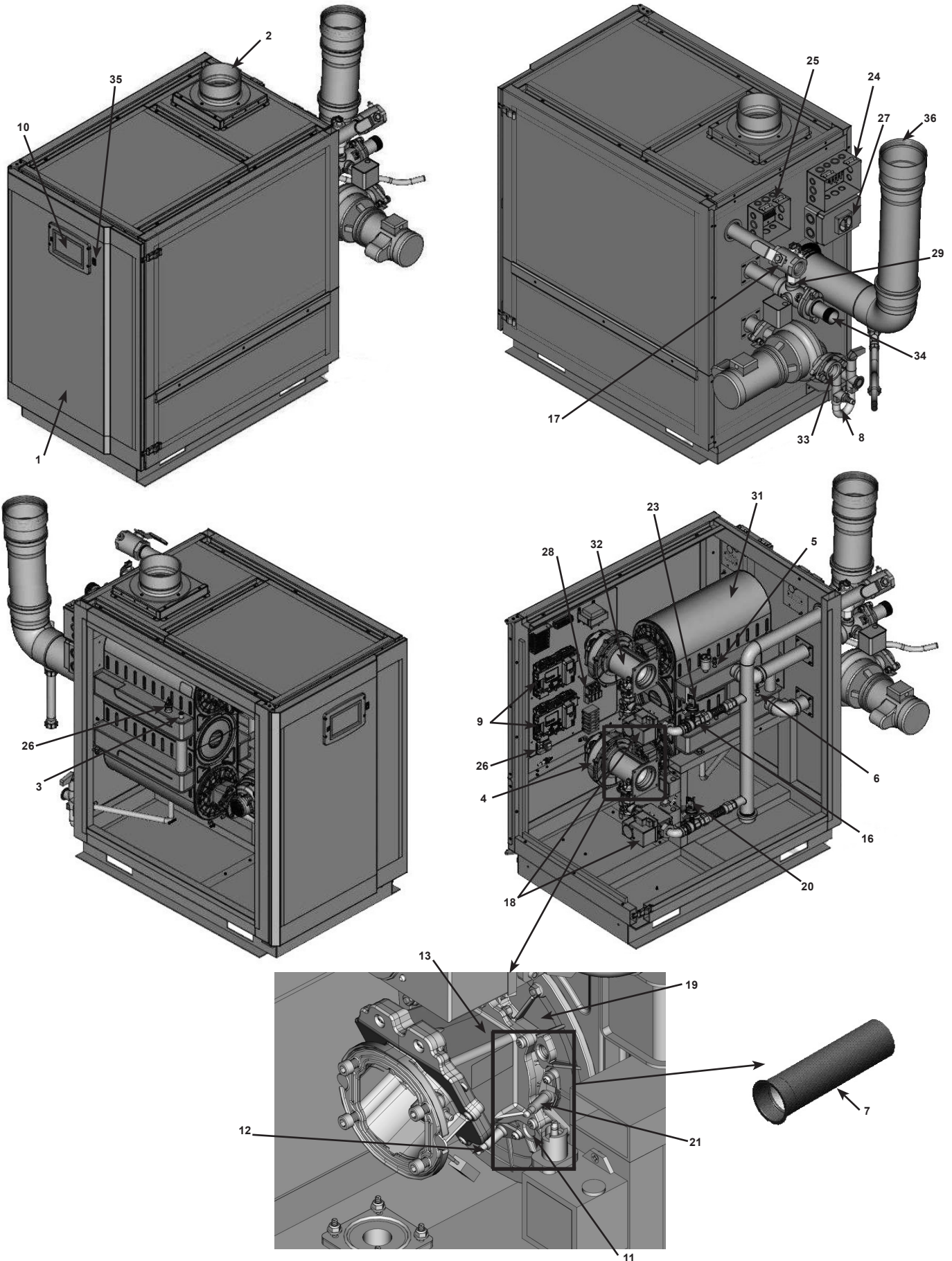

FIGURE 3. SINGLE HEAT EXCHANGER WATER HEATER COMPONENTS

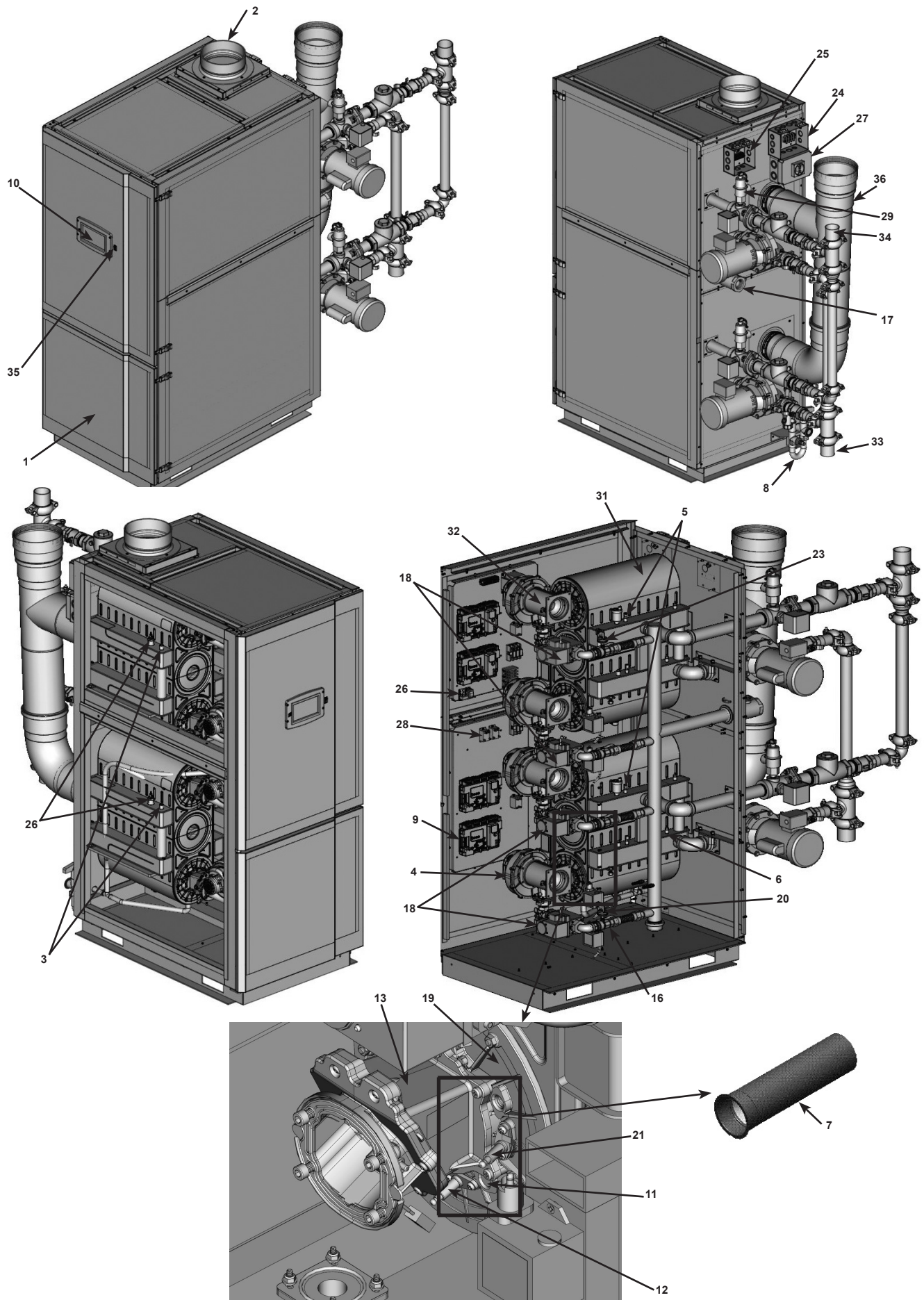

FIGURE 4. DOUBLE HEAT EXCHANGER WATER HEATER COMPONENTS

COMPONENT DESCRIPTION

1. Front access door:

Provides access to the gas train, burner controllers and the heat exchanger.

2. Air Filter Box:

Allows for the connection of the PVC air intake pipe to the water heater through a standard PVC adapter. It uses a filter mounted inside the box to prevent dust and debris from entering the water heater.

3. Automatic air vents:

Designed to remove trapped air from the heat exchanger coils.

4. Blowers:

The blowers pull in air and gas through the venturis. Air and gas mix inside the venturi and are pushed into the burners, where they burn inside the combustion chamber.

5. Inlet temperature sensors

These sensors monitor system return water temperature.

6. Outlet temperature sensors/High Limits

These sensors monitor water heater outlet water temperature. The water heater modulates based on the Lead Lag Sensor connected to the tank.

7. Burners

Made with metal fiber and stainless steel construction, the burners use pre-mixed air and gas and provide a wide range of firing rates.

8. Condensate Trap

Disposes the condensate produced from heat exchanger and houses a switch that detects in case of blockage.

9. Control modules

The control modules respond to internal and external signals and control the blowers, gas valves, and pumps to meet the heating demand.

10. Touch Screen Display

Digital controls with touch screen technology and full color display.

11. Sight glass

The quartz sight glass provides a view of the flame for inspection purposes.

12. Flame sensors

Used by the control module to detect the presence of burner flame.

13. Flap valves

Prevents recirculation of flue products when only one burner is running.

14. Flue gas sensors (not visible)

These sensors monitor the flue gas exit temperature. The control modules will modulate and shut down the water heater if the flue gas temperature gets too hot. This protects the flue pipe from overheating.

15. Flue pipe adapter (not visible)

Allows for the connection of the PVC vent pipe system to the water heater.

16. Gas shutoff valves (Internal unit)

Manual valves used to isolate the gas valves from the burners.

17. Main gas shutoff valve (External unit)

Manual valve used to isolate the water heater from the gas supply.

18. Automatic modulating gas valve

The gas valve with the addition of venturi and blower are used for modulating premix appliances.

19. Heat exchanger access covers

Allows access to the combustion side of the heat exchanger coils.

20. High gas pressure switch

Switch provided to detect excessive supply gas pressure.

21. Spark Igniter

Provides direct spark for igniting the burners.

22. Power supply terminals (not visible)

The main power to the water heater is supplied through the terminals housed inside the high voltage junction box.

23. Low gas pressure switch

Switch provided to detect low gas supply pressure.

24. High voltage connection box

This box has terminals for connecting the main power supply (120V) to the water heater and outputs power supply (120V) for the pumps from the water heater control. This box has terminals for low voltage devices such as condensate trap and flow switch.

25. Sensors/Communication Box

Connects sensors to tank sensor/header sensor and external connections to building managements systems through MODBUS.

26. Low water cutoff board and sensor probe (LWCO)

Device used to ensure adequate water is supplied to the water heater. In the event of inadequate water levels, LWCO will ensure water heater shut down. LWCO board is connected to the electronic panel, whereas the sensor probe is connected to the heat exchanger.

27. Main power supply switch

Turns 120 VAC ON/OFF to the water heater.

28. Pump relay

The pump relays are used for providing power to the water heater.

29. Pressure relief valve

Protects the heat exchangers from an over pressure condition. The relief valve will be set at particular PSI, depending on models.

30. Reset switch (optional) (not visible)

Reset switch for the low water cutoff.

31. Stainless steel heat exchangers

Allows system water to flow through specially designed coils.

32. Venturi

The venturi is a gas/air mixing unit that allows modulation of a premix burner with constant gas/air ratio.

33. Water inlet

Water connection that return water from the system to the heat exchangers.

34. Water outlets

A NPT water connection that supplies hot water to the system.

35. Enable/Disable Switch

This is an emergency water heater turn off switch which disconnects the interlock voltage to the control board, hence turning off the power supply to the gas valves. **Do not use this switch for turning off the water heater, this should be done from the touch screen display, using the Operational Switch on the Lead Lag screen.**

36. Vent outlet

Provides an outlet for combustion gases to outdoor.

CONTROL COMPONENTS

THE CONTROL SYSTEM

The R7910A1138 is a burner control system that provides heat control, flame supervision, circulation pump control, fan control, water heater control sequencing, and electric ignition function. It will also provide status and error reporting.

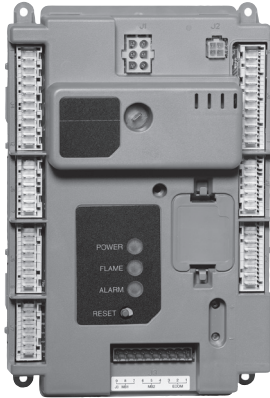

FIGURE 5. BURNER CONTROL SYSTEM

SPARK IGNITER

The spark igniter is a device that ignites the main burner. When power is supplied to the igniter electrode, an electric arc is created between the electrode and the ground terminal which ignites the main burner.

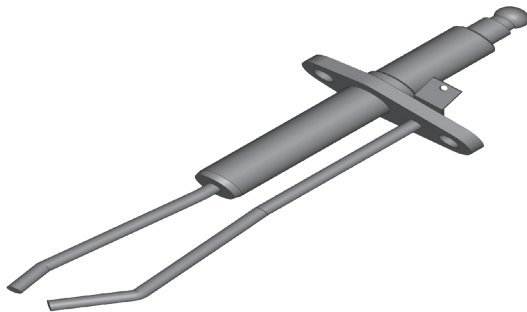

FIGURE 6. SPARK IGNITER

LOW/HIGH GAS PRESSURE SWITCH

This XWH is equipped with a low gas pressure switch which meets the CSD-1 code requirements.

The Low Gas Pressure Switch is normally open and remains open if the pressure is below the preset pressure. It closes as soon as the gas supply pressure is above the minimum supply pressure.

The High Gas Pressure Switch is normally closed and is used to detect excessive gas pressure.

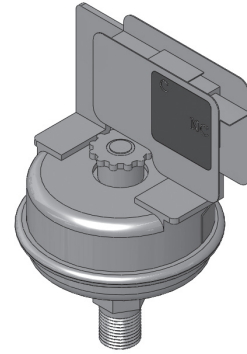

FIGURE 7. LOW/HIGH GAS PRESSURE SWITCH

GAS CONTROL VALVE

The gas valve is a normally closed servo regulated gas valve. The valve opens only when energized by the burner control and closes when the power is removed. The burner control supplies 24 volts to the gas valve during operation.

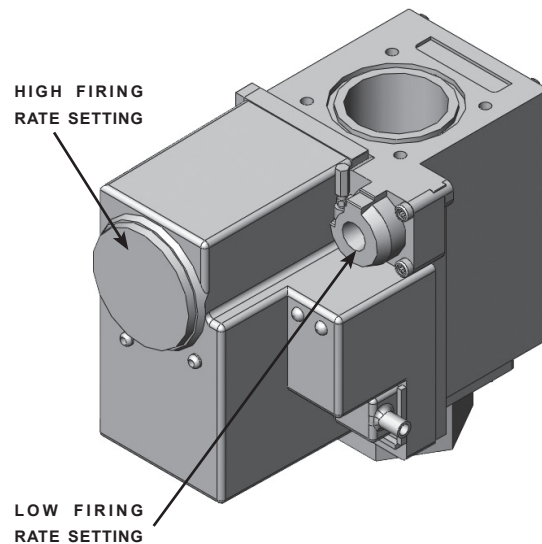

FIGURE 8. GAS CONTROL VALVE

WATER FLOW SWITCH

The water flow switch activates when sufficient water flow has been established. Switch will not close when water flow is not present.

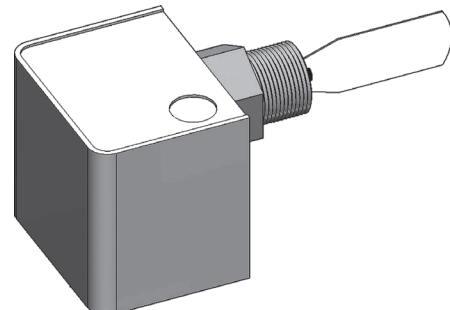

FIGURE 9. WATER FLOW SWITCH

FLAME SENSOR

Each burner is equipped with a flame sensor to detect the presence of the burner flames at high and low fire conditions. If no flame is sensed, the gas valve will close automatically. The voltage sensed by the flame sensor will also be displayed on the Burner Screen.

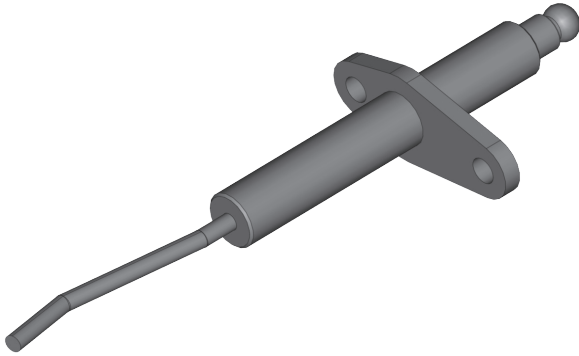

FIGURE 10. FLAME SENSOR

WATER TEMPERATURE LIMIT CONTROLS

CAUTION

Limit Controls

Limit controls are safety devices and are NOT to be used as an operating device (thermostat).

This water heater incorporates an outlet water sensor having dual sensors, that are factory set at 210°F (99°C).

MAIN POWER SUPPLY SWITCH

The main power supply switch is a padlockable switch. This switch provides 120V from the power supply to the water heater.

This switch needs to be turned off when servicing the water heater.

NOTE: The Enable/Disable (Interlock) Switch on the front of the water heater does not interrupt electrical power to the water heater.

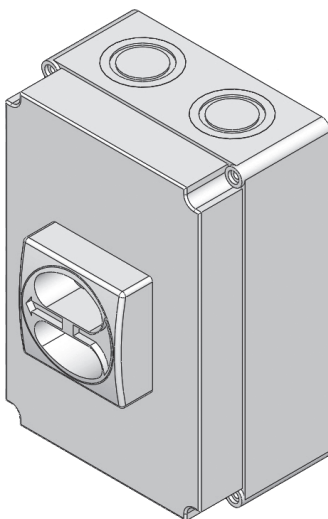

FIGURE 11. MAIN POWER SUPPLY SWITCH

WATER TEMPERATURE SENSORS

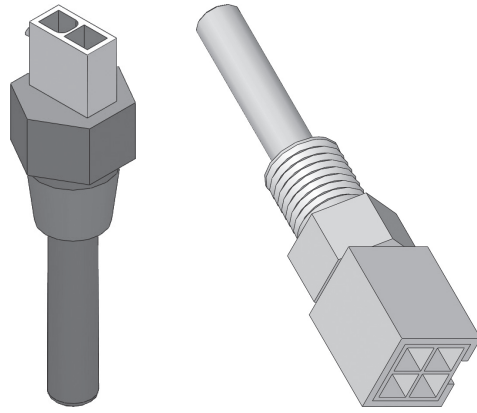

FIGURE 12. WATER TEMPERATURE SENSORS

Temperature sensors are threaded immersion probes. Temperature probes have embedded temperature sensors (thermistors). The water heater's control system monitors these sensors to determine water temperature at various points in the system.

INLET AND OUTLET TEMPERATURE SENSORS

All models have two inlet and two outlet temperature sensors for each heat exchanger, factory installed to monitor the water temperature entering and leaving the water heater. The Inlet Probe is a temperature sensor only and has two leads. The Outlet probe also contains the manual reset high temperature limit switch and has four leads. The control system displays the Inlet and Outlet water temperatures sensed from these two sensors on the default Temperatures screen.

REMOTE SENSORS

All models are supplied from the factory with a remote sensor. The remote sensor is used to control system water temperature for a single water heater in a domestic hot water storage tank.

The water heater will modulate its firing rate in response to the actual system temperature and load conditions. The control system displays the temperature sensed from the remote sensor as the "Lead Lag" temperature on the default Temperatures screen.

LOW WATER CUTOFF DEVICE (LWCO)

Low water cutoff device is normally a closed switch that opens when water drops below a preset level. Each model is equipped with a factory installed LWCO. LWCO board is connected to the electronic panel, whereas the sensor probe is connected to the heat exchanger.

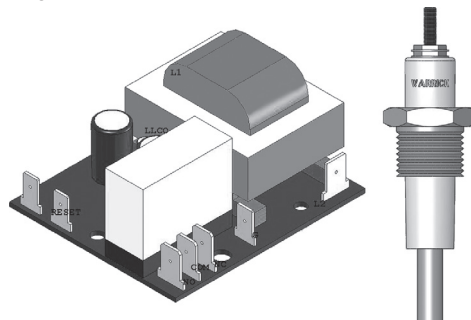

FIGURE 13. LWCO BOARD AND PROBE

INSTALLATION CONSIDERATIONS

GENERAL

If the system is to be filled with water for testing or other purposes during cold weather and before actual operation, care must be taken to prevent freezing of water in the system. Failure to do so may cause the water in the system to freeze with resulting damage to the system. Damage due to freezing is not covered by the warranty.

Figure 76 on Page 79 shows a typical primary, secondary piping method. This is the preferred piping method for most circulating water heaters. Other piping methods, however, may provide good system operation. A prime concern when designing heating systems is the maintenance of proper flow through the unit during water heater operation. The secondary pump should be sized per the recommended flow rate of the water heater, see Dimension and Capacity Data section in this manual.

Before locating the water heater:

1. Check for nearby connection to:
 - System water piping
 - Venting connections
 - Gas supply piping
 - Electrical power
2. Locate the water heater so that if water connections should leak, water damage will not occur. When such locations cannot be avoided, it is recommended that a suitable drain pan, adequately drained, be installed under the appliance. The pan must not restrict combustion air flow. Under no circumstances is the manufacturer to be held responsible for water damage in connection with this appliance, or any of its components.
3. Check area around the water heater. Remove any combustible materials, gasoline and other flammable liquids.
4. Make sure the gas control system components are protected from dripping or spraying water or rain during operation or service.
5. If a new water heater will replace an existing water heater, check for and correct system problems, such as:
 - System leaks causing oxygen corrosion or heat exchanger cracks from hard water deposits.
 - Lack of freeze protection in water heater water causing system and water heater to freeze and leak.

CIRCULATING PUMP

A circulating pump is used when a system requires a circulating loop or there is a storage tank used in conjunction with the water heater. Install in accordance with the current edition of the National Electrical Code, NFPA 70 or the Canadian Electrical Code, CSA C22.1. All bronze circulating pumps are recommended for use with commercial water heaters. Some circulating pumps are manufactured with sealed bearings and do not require further lubrication. Some circulating pumps must be periodically oiled. Refer to the pump manufacturer's instructions for lubrication requirements.

XWH Models: The circulating pump is integral to the XWH models. This pump has been lubricated at the factory, and future lubrication should be in accordance with the motor manufacturer's instructions provided as a supplement to this manual.

PRIMARY SYSTEM CONTROL

All XWH installations require a "Primary System Control" that senses and reacts to water temperature inside the storage tank on domestic water applications. The Primary System Control will activate and deactivate water heater heating cycles based on its setpoint and current system water temperature. There are three suitable methods to configure a Primary System Control. One of these three methods must be used.

1. The Primary System Control can be the water heater's control system working with the factory supplied Header Sensor, installed inside the storage tank on domestic water applications.
2. Alternatively, the Burner Control system can be used as a Primary System Control. It will also provide water heater status and error reporting. Multiple water heaters can be joined together to heat a system instead of a single, larger burner or water heater. Using water heaters in parallel is more efficient, costs less, reduces emissions, improves load control, and is more flexible than the traditional large water heater.
3. MB2 and COM2 ports can be used for Building Management Systems.

INTERNAL CONTAMINANTS

The system must be internally cleaned and flushed after a new or replacement water heater has been installed, to remove contaminants that may have accumulated during installation. This is extremely important when a replacement water heater is installed into an existing system where Stop Leak or other water heater additives have been used.

Failure to clean and flush the system can produce acid concentrations that become corrosive, and leads to heat exchanger failure.

All hot water heating systems should be completely flushed with a grease removing solution to assure trouble-free operation. Pipe joint compounds, soldering paste, grease on tubing and pipe all tend to contaminate a system

Failure to flush contaminants from a system can cause solids to form on the inside of heat exchangers, create excessive blockage of water circulation, deterioration of the pump seals and impellers.

WATER LINE CONNECTIONS

Piping diagrams will serve to provide the installer with a reference for the materials and methods of piping necessary for installation. It is essential that all water piping be installed and connected as shown on the diagrams. Check the diagrams to be used thoroughly before starting installation to avoid possible errors and to minimize time and material cost. It is essential that all water piping be installed and connected as shown on the diagrams. See Figure 76 on Page 79 and Figure 77 on Page 80.

CLOSED WATER SYSTEMS

Water supply systems may, because of code requirements or such conditions as high line pressure, among others, have installed devices such as pressure reducing valves, check valves, and back flow preventers. Devices such as these cause the water system to be a closed system.

THERMAL EXPANSION

As water is heated, it expands (thermal expansion). In a closed system the volume of water will increase when it is heated. As the volume of water increases there will be a corresponding increase in water pressure due to thermal expansion. Thermal expansion can cause premature failure (leakage). This type of failure is not covered under the limited warranty. Thermal expansion can also cause intermittent Temperature-Pressure Relief Valve operation: water discharged from the valve due to excessive pressure build up. This condition is not covered under the limited warranty. The Temperature-Pressure Relief Valve is not intended for the constant relief of thermal expansion.

A properly sized thermal expansion tank must be installed on all closed systems to control the harmful effects of thermal expansion. Contact a local plumbing service agency to have a thermal expansion tank installed.

PRESSURE RELIEF VALVE

An ASME rated pressure relief valve is furnished with the water heater. A fitting for the relief valve is provided in the top of the water heater. Never operate the heating elements without being certain the water heater is filled with water and a properly sized pressure relief valve is installed in the relief valve opening provided.

The pressure rating of the relief valve should be equal to or less than the rated pressure capacity of any component in the system including the water heater. Should the valve need to be replaced, call the toll free phone number listed on the back of this manual for further technical assistance

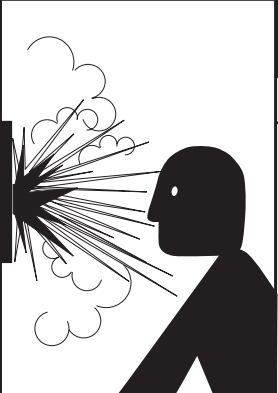
	WARNING
	Explosion Hazard <ul style="list-style-type: none">• Relief Valve must comply with ASME code.• Properly sized Relief Valve must be installed in opening provided.• Can result in overheating and excessive tank pressure.• Can cause serious injury or death.

A discharge pipe from the relief valve should terminate at an adequate floor drain. Do not thread, plug, or cap the end of drain line.

CAUTION
Water Damage Hazard
<ul style="list-style-type: none">• Pressure Relief Valve discharge pipe must terminate at adequate drain.

The Discharge Pipe:

- Shall not be smaller in size than the outlet pipe size of the valve, or have any reducing couplings or other restrictions.
- Shall not be plugged or blocked.
- Shall not be exposed to freezing temperatures.
- Shall be of material listed for hot water distribution.
- Shall be installed so as to allow complete drainage of both the relief valve and the discharge pipe.
- Must terminate a maximum of six inches above a floor drain or external to the building. In cold climates, it is recommended that the discharge pipe be terminated at an adequate drain inside the building.
- Shall not have any valve or other obstruction between the relief valve and the drain.

Once the water heater is installed and filled with water and the system is pressurized, manually test the operation of the pressure relief valve. See the Maintenance Procedures section of this manual for instructions.

Your local code authority may have other specific safety relief valve requirements not covered below. If any pressure relief valve is replaced, the replacement valve must comply with the requirements for Relief Valves for Hot Water Supply Systems, ANSI Z21.22 • CSA 4.4, and the code requirements of ASME.

XWH water heaters are shipped with a 125 psi (860 kPa) pressure relief valve that must be installed in the water outlet as near to the water heater as possible.

This ASME-rated valve has a discharge capacity that exceeds maximum water heater input rating and a pressure rating that does not exceed maximum working pressure shown on water heater rating plate.

In addition, a CSA design-certified and ASME-rated temperature and pressure (T&P) relief valve must be installed on each and every water storage tank in hot water supply system. The T&P relief valve must comply with applicable construction provisions of Standard for Relief Valves for Hot Water Supply Systems, ANSI Z21.22 or CSA 4.4. T&P relief valve must be of automatic reset type and not embody a single-use type fusible plug, cartridge or linkage.

T&P relief valve should have a temperature rating of 210°F (99°C), a pressure rating not exceeding lowest rated working pressure of any system component, and a discharge capacity exceeding total input of water heaters supplying water to storage tank.

Locate the T&P relief valve (a) in the top of the tank, or (b) in the side of the tank on a centerline within the upper 6 inches (152 mm) of the top of the tank, see Figure 76 and Figure 77. The tapping should be threaded in accordance with the current edition of the Standard for Pipe Threads, General Purpose (inch), ANSI/ASME B1.20.1. The location of, or intended location for, the T&P relief valve should be readily accessible for servicing or replacement.

GAS CONNECTIONS

Make sure the gas on which water heater is to operate is same as that specified on the rating plate. Do not install water heater if equipped for a different type of gas. Consult your gas supplier.

This water heater is not intended to operate at gas supply pressure other than shown on the rating plate. A lock-up or positive shut-off type regulator must be installed in gas supply line. For proper gas regulation the lock-up style regulators must be installed no closer than a minimum of 3 feet (0.9 m) from the water heater and a maximum of 8 feet (2.4 m) away from the

water heater. Exposure to higher gas supply pressure may cause damage to gas valves which can result in fire or explosion. If overpressure has occurred such as through improper testing of gas lines or emergency malfunction of supply system, the gas valves must be checked for safe operation. Make sure that the outside vents on supply regulators and the safety vent valves are protected against blockage. These are parts of the gas supply system, not water heater. Vent blockage may occur during ice build-up or snowstorms.

CAUTION

Gas Supply

- The gas type must match the gas type on the rating plate.
- Gas supply pressure must match pressure indicated on the rating plate
- Isolate water heater from gas supply piping system.
- Disconnect water heater and main manual gas shutoff valve from gas supply during pressure testing of gas supply system.

The water heater must be isolated from the gas supply piping system by closing its main manual gas shut off valve during any pressure testing of the gas supply piping system at test pressures equal to or less than 1/2 psig.

Disconnect the water heater and its main manual gas shut-off valve from the gas supply piping during any pressure testing of the gas supply system over 1/2 psig. The gas supply line must be capped when not connected to the water heater.

It is important to guard against gas valve fouling from contaminants in the gas ways. Such fouling may cause improper operation, fire or explosion. If copper supply lines are used they must be approved for gas service.

When local codes require a main manual shut-off valve outside the water heater jacket, a suitable main manual shut-off valve must be installed in a location complying with those codes.

Before attaching gas line be sure that all gas pipe is clean on inside. To trap any dirt or foreign material in the gas supply line, a sediment trap must be incorporated in piping. The sediment trap must be readily accessible and not subject to freezing conditions. Install in accordance with recommendations of serving gas supplier. Refer to the current edition of the National Fuel Gas Code, ANSI Z223.1/NFPA 54 or the Natural Gas and Propane Installation Code, CAN/CSA B149.1

Size of gas supply piping may be larger than heater connection on installations where a significant run of piping is required.

To prevent damage, care must be taken not to apply too much torque when attaching gas supply pipe to water heater gas inlet. When installing and tightening gas piping use a second wrench to hold the gas valve to keep the valve from turning. To prevent damage to the gas valve do not use pipe wrench on the valve body.

Fittings and unions in gas line must be of metal to metal type. Apply joint compounds (pipe dope) sparingly and only to the male threads of pipe joints. Do not apply compound to the first two threads. Use compounds resistant to the action of liquefied petroleum gases. The water heater and its gas connection must be leak tested before placing the water heater in operation.

GAS SUPPLY LINE SIZING

The gas piping installation must be capable of supplying the maximum probable gas demand without excessive pressure loss. Depending on local practices, the ALLOWABLE PRESSURE LOSS between the gas meter, or service regulator and each

appliance is generally 0.3 or 0.5 inches of water column (0.075 or 0.124 kPa).

For single water heater installation, refer to Table 7 and Table 8 to size iron pipe or equivalent gas supply line size to be used with single unit.

For multiple water heater installation or installations of a single water heater with other gas appliances, please refer to Table 9 and Table 10 on Page 19 to size iron pipe or equivalent gas supply line. These tables are taken from the current edition of the National Fuel Gas Code, ANSI Z223.1/NFPA 54 or the Natural Gas and Propane Installation Code, CAN/CSA B149.1.

- Table 9 is based on a pressure drop of 0.5 inches water column (0.124 kPa), and a gas with a specific gravity of 0.60 and a heating value of 1,000 BTU/ft³, approximately that of Natural Gas.
- Table 10 is based on a pressure drop of 0.5 inches water column (0.124 kPa), and a gas with a specific gravity of 1.53 and a heating value of 2,500 BTU/ft³, approximately that of Propane Gas.

Where it is necessary to use more than the average number of fittings (i.e., elbows, tees and valves in gas supply line) use a pipe larger than specified to compensate for increased pressure drop.

Table 7 and Table 8 shows the maximum equivalent gas pipe length for a single unit installation. It does not take into account other appliances that may be connected to the gas line. For installation of multiple units, or instances where several appliances are connected to the same line, use Table 9 and Table 10 for proper sizing.

**TABLE 7.
SINGLE UNIT INSTALLATION, SUGGESTED GAS PIPE SIZING. MAXIMUM EQUIVALENT PIPE LENGTH (IN FEET).**

BTU Input	2"		2-1/2"		3"		4"	
	Nat	Pro	Nat	Pro	Nat	Pro	Nat	Pro
920,000	70	150	175	—	—	—	—	—
1,300,000	40	100	100	200	—	—	—	—
1,700,000	20	60	70	150	200	—	—	—
2,000,000	20	50	50	100	150	—	—	—
2,600,000	10	30	30	70	90	200	—	—
3,400,000	—	—	20	40	50	125	200	—

Natural gas 1000 Btu/ft³, 0.60 specific gravity @ 0.3 in. w.c. pressure drop.
Propane gas 2500 Btu/ft³, 1.50 specific gravity @ 0.3 in. w.c. pressure drop.

**TABLE 8.
SINGLE UNIT INSTALLATION, SUGGESTED GAS PIPE SIZING. MAXIMUM EQUIVALENT PIPE LENGTH (IN FEET).**

BTU Input	2"		2-1/2"		3"		4"	
	Nat	Pro	Nat	Pro	Nat	Pro	Nat	Pro
920,000	125	200	200	—	—	—	—	—
1,300,000	80	175	175	—	—	—	—	—
1,700,000	40	100	100	—	—	—	—	—
2,000,000	30	80	80	200	200	—	—	—
2,600,000	20	50	50	125	150	—	—	—
3,400,000	10	30	30	70	90	200	—	—

Natural gas 1000 Btu/ft³, 0.63 specific gravity @ 0.5 in. w.c. pressure drop.
Propane gas 2500 Btu/ft³, 1.50 specific gravity @ 0.5 in. w.c. pressure drop.

CORROSIVE MATERIALS AND CONTAMINATION SOURCES

Products to avoid:

- Spray cans containing chloro/fluorocarbons
- Permanent wave solutions
- Chlorinated waxes/cleaners
- Chlorine-based swimming pool chemicals
- Calcium chloride used for thawing
- Sodium chloride used for water softening
- Refrigerant leaks
- Paint or varnish removers
- Hydrochloric acid/muriatic acid
- Cements and glues
- Antistatic fabric softeners used in clothes dryers
- Chlorine-type bleaches, detergents, and cleaning solvents found in household laundry rooms
- Adhesives used to fasten building products and other similar products

Areas likely to have contaminants:

- Dry cleaning/laundry areas and establishments
- Swimming pools
- Metal fabrication plants
- Beauty shops
- Refrigeration repair shops
- Photo processing plants
- Auto body shops
- Plastic manufacturing plants
- Furniture refinishing areas and establishments
- New building construction
- Remodeling areas

Common household products, pool and laundry products may contain fluorine or chlorine compounds. When these chemicals come in contact with the water heater, they react and can form strong acids. The acid can spoil the water heater wall, causing serious damage and may result in flue gas spillage or water heater water leakage into the building.

If the above mentioned contaminants and corrosive materials chemicals are present near the location of the water heater, make sure to remove the water heater permanently or relocate air inlet and vent terminations to other areas.

FIELD WIRING

120 VAC POWER SUPPLY WIRING

A dedicated, single phase, 30-60 amp (refer to Table 5 on Page 8) circuit breaker with a grounded neutral should be provided to supply power to the water heaters. Use #10 AWG wire for the 120 VAC power supply to the water heater. All 120 VAC power supply connections must be made as shown in Figure 14. These connections should be made at the rear of the unit where a wiring junction box is provided. Field installed power supply wiring to the water heater should be installed in conduit. This conduit and wiring should be separate from any other conduit/wiring to guard against EMI (electromagnetic interference).

POWER SUPPLY CHECK

To reduce the possibility of electrical interference with the water heater's control system the power supply voltage, polarity and ground must be checked. Using an AC volt meter check the 120 VAC power supply wiring from the breaker prior to making power supply connections at the water heater. Confirm the power supply voltage & polarity are correct and that an adequate ground connection is present by performing the three voltage tests below. See Figure 14 for wiring references.

Confirm RMS voltage between:

- H and GND = 108 VAC minimum, 132 VAC maximum.
- N and H = 108 VAC minimum, 132 VAC maximum.
- N and GND = < 1 VAC maximum.

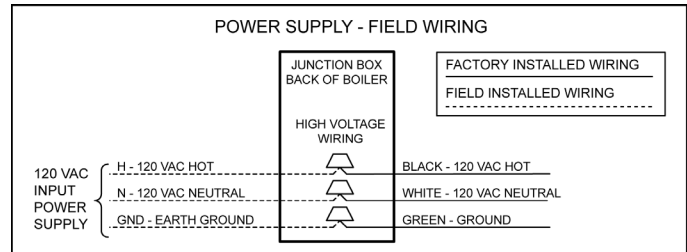

FIGURE 14. FIELD WIRING

LOW VOLTAGE CONTROL WIRING

1. Header Terminals: In XWH water heaters the header terminals are connected to the tank sensor where the temperature can be sensed. See Figure 15. The tank sensor is to be connected using the factory supplied sensor harness. The maximum length of the wire connecting from the water heater to the outdoor sensor must be no more than 50 feet (15.2 m).
2. MB2 and COM2 terminals are meant for building management systems.



FIGURE 15. LOW VOLTAGE CONTROL WIRING

All low voltage control wiring connections must be made as shown in Figure 14. These connections should be made at the rear of the unit where a wiring junction box is provided. Field installed wiring inside 1/2 inch conduit is installed between the junction box on the back of the water heater and the temperature probe and/or field supplied external control being used. This conduit and wiring should be separate from any other conduit/wiring to guard against EMI (electromagnetic interference).

TABLE 9. SUGGESTED PIPE SIZE FOR MULTIPLE GAS APPLIANCES (NATURAL GAS)

Nominal Iron Pipe Size (Inches)	Maximum Capacity of Pipe in BTU/hr and kW for Gas Pressures of 14 in. W.C. (0.5 psi) or Less and a Pressure Drop of 0.5 in. W.C. (based on 0.60 Specific Gravity Gas w/Heating Value of 1,000 BTU's/Ft3)																
	Length of Pipe in Feet (Meters)																
	10 (3.05)	20 (6.1)	30 (9.14)	40 (12.19)	50 (15.24)	60 (18.29)	70 (21.34)	80 (24.38)	90 (27.43)	100 (30.48)	125 (38.1)	150	175	200			
1 1/2	BTU/hr 2,100,000	1,460,000	1,180,000	990,000	900,000	810,000	750,000	690,000	650,000	620,000	550,000	500,000	460,000	—			
	kW 615	428	346	290	264	237	220	202	190	182	161	146	135	—			
2	BTU/hr 3,950,000	2,750,000	2,200,000	1,900,000	1,680,000	1,520,000	1,400,000	1,300,000	1,220,000	1,150,000	1,020,000	950,000	850,000	800,000			
	kW 1,157	805	644	556	492	445	410	381	357	337	299	278	249	234			
2 1/2	BTU/hr 6,300,000	4,350,000	3,520,000	3,000,000	2,650,000	2,400,000	2,250,000	2,050,000	1,950,000	1,850,000	1,650,000	1,500,000	1,370,000	1,280,000			
	kW 1,845	1,274	1,031	879	776	703	659	600	571	542	483	439	401	375			
3	BTU/hr 11,000,000	7,700,000	6,250,000	5,300,000	4,750,000	4,300,000	3,900,000	3,700,000	3,450,000	3,250,000	2,950,000	2,650,000	2,450,000	2,280,000			
	kW 3,222	2,255	1,830	1,552	1,391	1,259	1,142	1,084	1,010	952	864	776	718	668			
4	BTU/hr 23,000,000	15,800,000	12,800,000	10,900,000	9,700,000	8,800,000	8,100,000	7,500,000	7,200,000	6,700,000	6,000,000	5,500,000	5,000,000	4,600,000			
	kW 6,736	4,627	3,749	3,192	2,841	2,577	2,372	2,197	2,109	1,962	1,757	1,611	1,464	1,347			

TABLE 10. SUGGESTED PIPE SIZE FOR MULTIPLE GAS APPLIANCES (PROPANE GAS)

Nominal Iron Pipe Size (Inches)	Maximum Capacity of Pipe in BTU/hr and kW for Gas Pressures of 14 in. W.C. (0.5 psi) or Less and a Pressure Drop of 0.5 in. W.C. (based on 0.60 Specific Gravity Gas w/Heating Value of 1,000 BTU's/Ft3)																
	Length of Pipe in Feet (Meters)																
	10 (3.05)	20 (6.1)	30 (9.14)	40 (12.19)	50 (15.24)	60 (18.29)	70 (21.34)	80 (24.38)	90 (27.43)	100 (30.48)	125 (38.1)	150	175	200			
1 1/2	BTU/hr 3,276,000	2,277,600	1,840,800	1,544,400	1,404,000	1,263,600	1,170,000	1,076,400	1,014,000	967,200	858,000	780,000	717,600	670,800			
	kW 959	667	539	452	411	370	343	315	297	283	251	228	210	196			
2	BTU/hr 6,162,000	4,290,000	3,432,000	2,964,000	2,620,800	2,371,200	2,184,000	2,028,000	1,903,200	1,794,000	1,591,200	1,482,000	1,326,000	1,248,000			
	kW 1,805	1,256	1,005	868	768	694	640	594	557	525	466	434	388	366			
2 1/2	BTU/hr 9,828,000	6,786,000	5,491,200	4,680,000	4,134,000	3,744,000	3,510,000	3,198,000	3,042,000	2,886,000	2,574,000	2,340,000	2,137,200	1,999,800			
	kW 2,878	1,987	1,608	1,371	1,211	1,097	1,028	937	891	845	754	685	626	585			
3	BTU/hr 17,160,000	12,012,000	9,750,000	8,268,000	7,410,000	6,708,000	6,084,000	5,772,000	5,382,000	5,070,000	4,602,000	4,134,000	3,822,000	3,556,800			
	kW 5,026	3,518	2,856	2,421	2,170	1,965	1,782	1,690	1,576	1,485	1,348	1,211	1,119	1,042			
4	BTU/hr 35,880,000	24,648,000	19,968,000	17,004,000	15,132,000	13,728,000	12,636,000	11,700,000	11,232,000	10,452,000	9,360,000	8,580,000	7,800,000	7,176,000			
	kW 10,508	7,219	5,848	4,980	4,432	4,021	3,701	3,427	3,290	3,061	2,741	2,513	2,284	2,102			

GENERAL REQUIREMENTS

REQUIRED ABILITY

Installation or service of this water heater requires ability equivalent to that of a licensed tradesman in the field involved. Plumbing, air supply, venting, gas supply, and electrical work are required.

LOCATION

When installing the water heater, consideration must be given to proper location. The location selected should provide adequate air supply and be as centralized with the piping system as possible.

⚠ CAUTION

Property Damage Hazard

This water heater should not be installed on carpeting.

This water heater should not be located in an area where it may be subject to freezing.

This water heater must be located near a floor drain. It should be located in an area where leakage from the water heater or connections will not result in damage to the adjacent area or to lower floors of the structure.



⚠ WARNING

Fire Hazard

Flammable items, pressurized containers, or any other potential fire hazard articles must never be placed on or adjacent to the water heater. Open containers or flammable material should not be stored or used in the same room with the water heater.

⚠ DANGER

Fire Explosion Hazard



There is a risk of fire or explosion in areas where gasoline, other flammable liquids, or engine driven equipment and vehicles are stored, operated, or repaired when a fuel burning appliance such as a water heater is operated.

Flammable vapors are heavy and travel along the floor. They may be ignited by sparks causing fire or explosion.

REPLACING EXISTING COMMON VENTED WATER HEATER

NOTE: This section does not describe a method for common venting XWH units. It describes what must be done when a unit is removed from a common vent system. The XWH units require special vent systems and fans for common vent. Contact the factory if you have questions about common venting XWH units.

When an existing water heater is removed from a common venting system, the common venting system is likely to be too large for proper venting of the appliances remaining connected to it. At the time of removal of an existing water heater, the following steps should be followed with each appliance remaining connected to the common venting system placed in operation, while the other appliances remaining connected to the common venting system are not in operation.

1. Seal any unused openings in the common venting system.
2. Visually inspect the venting system for proper size and horizontal pitch and determine there is no blockage or restriction, leakage, corrosion and deficiencies which could cause an unsafe condition.
3. In so far as it is practical, close all building doors and windows and all doors between the space in which the appliances remaining connected to the common venting system are located and other spaces of the building. Turn on clothes dryers and any appliance not connected to the common venting system. Turn on any exhaust fans, such as range hoods and bathroom exhausts, so they will operate at maximum speed. Do not operate a summer exhaust fan. Close fireplace dampers.
4. Place in operation the appliance being inspected. Follow the lighting instructions. Adjust thermostat so the appliance will operate continuously.
5. Test for spillage at the draft hood relief opening after 5 minutes of main burner operation. Use the flame of a match or candle, or smoke from a cigarette, cigar or pipe.
6. After it has been determined that each appliance remaining connected to the common venting system properly vents when tested as outlined above, return doors, windows, exhaust fans, fireplace dampers and any other gas-burning appliance to their previous condition of use.
7. Any improper operation of the common venting system should be corrected so that the installation conforms with the National Fuel Gas Code, ANSI Z223.1/NFPA 54 and/or CSA B149.1, Installation Codes. When resizing any portion of the common venting system, the common venting system should be resized to approach the minimum size as determined using the appropriate tables and guidelines in the National Fuel Gas Code, ANSI Z223.1/NFPA 54 and/or CSA B149.1, Installation Codes.

This water heater is intended for Indoor Installation only, and should not be installed where freezing temperatures or any moisture could damage the external components of the water heater.

PANELS AND COVERS

All panels and covers (e.g. control and junction box covers; front, side and rear panels of water heater) must be in place after service and/or before operation of water heater. This will ensure that all gas ignition components will be protected from water.

The XWH is a low-pressure water heater to be used as hot water heating (potable water only) applications.

CHEMICAL VAPOR CORROSION

Water heater corrosion and component failure can be caused by the heating and breakdown of airborne chemical vapors. Spray can propellants, cleaning solvents, refrigerator and air conditioning refrigerants, swimming pool chemicals, calcium and sodium chloride (water softener salt), waxes, and process chemicals are typical compounds which are potentially corrosive. These materials are corrosive at very low concentration levels with little or no odor to reveal their presence.

Products of this sort should not be stored near water heater. Also, air which is brought in contact with water heater should not contain any of these chemicals. If necessary, uncontaminated air should be obtained from remote or outside sources. Failure to observe this requirement will void warranty.

INSTALLATION CLEARANCES

This water heater is approved for installation in an alcove with minimum clearances to combustibles.

TABLE 11. INSTALLATION CLEARANCES

	RECOMMENDED SERVICE CLEARANCES	CLEARANCES FROM COMBUSTIBLE MATERIALS
Front	30" (762 mm)	8" (203 mm)
Rear	36" (610 mm)	24" (610 mm)
Left	24" (610 mm)	1" (25.4 mm)
Right	24" (610 mm)	2" (51 mm)
Top	24" (610 mm)	6" (152 mm)

2" (51 mm) clearance is allowable from combustible construction for hot water pipes.

Sufficient area should be provided at the front and rear of the unit for proper servicing. In a utility room installation, the door opening should be wide enough to allow the water heater to enter or to permit the replacement of another appliance such as a water heater.

FLOORING AND FOUNDATION:

All models are approved for installation on combustible flooring, but must never be installed on carpeting. Do not install the water heater on carpeting even if foundation is used. Fire can result, causing severe personal injury, death, or substantial property damage.

If flooding is possible, elevate the water heater sufficiently to prevent water from reaching the water heater.

LEVELING

Because this unit is a condensing unit, it has a condensation disposal system that requires this unit to be level to properly drain. Each unit should be checked to be certain that it is level prior to starting the unit.

If the unit is not level, obtain and insert shims under the feet at the frame base to correct this condition.

AIR REQUIREMENTS

⚠ WARNING

Breathing Hazard - Carbon Monoxide Gas



- Install appliance in accordance with the Instruction Manual and NFPA 54 or CAN/CSA-B149.1.
- To avoid injury, combustion and ventilation air must be taken from outdoors.
- Do not place chemical vapor emitting products near water heater.

Breathing carbon monoxide can cause brain damage or death. Always read and understand instruction manual.

For safe operation an adequate supply of fresh uncontaminated air for combustion and ventilation must be provided.

An insufficient supply of air can cause recirculation of combustion products resulting in contamination that may be hazardous to life. Such a condition often will result in a yellow, luminous burner flame, causing sooting of the combustion chamber, burners and flue tubes and creates a risk of asphyxiation.

Do not install the water heater in a confined space unless an adequate supply of air for combustion and ventilation is brought in to that space using the methods described in the Confined Space section that follows.

Never obstruct the flow of ventilation air. If you have any doubts or questions at all, call your gas supplier. Failure to provide the proper amount of combustion air can result in a fire or explosion and cause property damage, serious bodily injury or death.

UNCONFINED SPACE

An unconfined space is one whose volume is not less than 50 cubic feet per 1,000 Btu/hr (4.8 cubic meters per kW) of the total input rating of all appliances installed in the space. Rooms communicating directly with the space, in which the appliances are installed, through openings not furnished with doors, are considered a part of the unconfined space.

Makeup air requirements for the operation of exhaust fans, kitchen ventilation systems, clothes dryers and fireplaces shall also be considered in determining the adequacy of a space to provide combustion, ventilation and dilution air.

UNUSUALLY TIGHT CONSTRUCTION

In unconfined spaces in buildings, infiltration may be adequate to provide air for combustion, ventilation and dilution of flue gases. However, in buildings of unusually tight construction (for example, weather stripping, heavily insulated, caulked, vapor barrier, etc.) additional air must be provided using the methods described in the Confined Space section that follows.

CONFINED SPACE

A confined space is one whose volume is less than 50 cubic feet per 1,000 Btu/hr (4.8 cubic meters per kW) of the total input rating of all appliances installed in the space.

Openings must be installed to provide fresh air for combustion, ventilation and dilution in confined spaces. The required size for the openings is dependent on the method used to provide fresh air to the confined space and the total Btu/hr input rating of all appliances installed in the space.

DIRECT VENT APPLIANCES

Appliances installed in a direct vent configuration that derive all air for combustion from the outdoor atmosphere through sealed intake air piping are not factored in the total appliance input Btu/hr calculations used to determine the size of openings providing fresh air into confined spaces.

EXHAUST FANS

Where exhaust fans are installed, additional air shall be provided to replace the exhausted air. When an exhaust fan is installed in the same space with a water heater, sufficient openings to provide fresh air must be provided that accommodate the requirements for all appliances in the room and the exhaust fan. Undersized openings will cause air to be drawn into the room through the water heater's vent system causing poor combustion. Sooting, serious damage to the water heater and the risk of fire or explosion may result. It can also create a risk of asphyxiation.

LOUVERS AND GRILLES

The free areas of the fresh air openings in the instructions that follow do not take in to account the presence of louvers, grilles or screens in the openings.

The required size of openings for combustion, ventilation and dilution air shall be based on the "net free area" of each opening. Where the free area through a design of louver or grille or screen is known, it shall be used in calculating the size of opening required to provide the free area specified. Where the louver and grille design and free area are not known, it shall be assumed that wood louvers will have 25% free area and metal louvers and grilles will have 75% free area. Non motorized louvers and grilles shall be fixed in the open position.

FRESH AIR OPENINGS FOR CONFINED SPACES

The following instructions shall be used to calculate the size, number and placement of openings providing fresh air for combustion, ventilation and dilution in confined spaces. The illustrations shown in this section of the manual are a reference for the openings that provide fresh air into confined spaces only. Do not refer to these illustrations for the purpose of vent installation. See Venting section on Page 24 for complete venting installation instructions.

OUTDOOR AIR THROUGH TWO OPENINGS

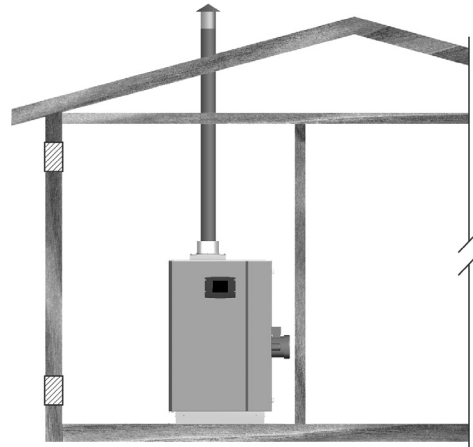

FIGURE 16. OUTDOOR AIR THROUGH TWO OPENINGS

The confined space shall be provided with two permanent openings, one commencing within 12 inches (300 mm) of the top and one commencing within 12 inches (300 mm) of the bottom of the enclosure. The openings shall communicate directly with the outdoors. See Figure 16.

Each opening shall have a minimum free area of 1 square inch per 4,000 Btu/hr (550 mm² per kW) of the aggregate input rating of all appliances installed in the enclosure. Each opening shall not be less than 100 square inches (645 cm²).

OUTDOOR AIR THROUGH ONE OPENING

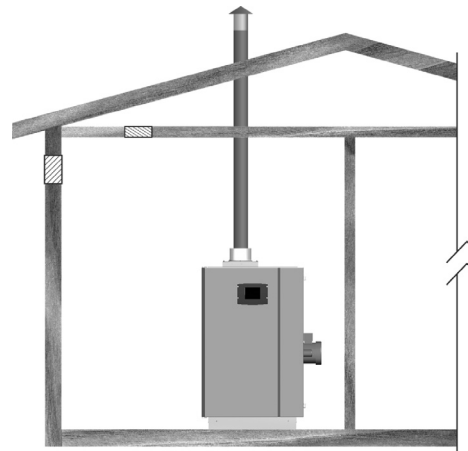

FIGURE 17. OUTDOOR AIR THROUGH ONE OPENING

Alternatively a single permanent opening, commencing within 12 inches (300 mm) of the top of the enclosure, shall be provided. See Figure 17. The water heater shall have clearances of at least 1 inch (25 mm) from the sides and back and 6 inches (150 mm) from the front of the appliance. The opening shall directly communicate with the outdoors or shall communicate through a vertical or horizontal duct to the outdoors or spaces that freely communicate with the outdoors and shall have a minimum free area of the following:

- 1 square inch per 3000 Btu/hr (700 mm² per kW) of the total input rating of all appliances located in the enclosure, and
- Not less than the sum of the areas of all vent connectors in the space.

OUTDOOR AIR THROUGH TWO HORIZONTAL DUCTS

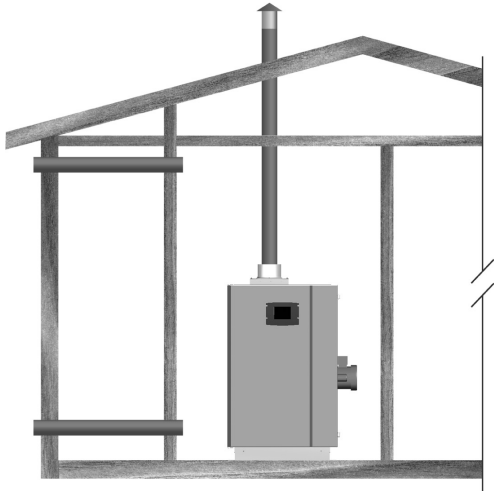

FIGURE 18. OUTDOOR AIR THROUGH TWO HORIZONTAL DUCTS

The confined space shall be provided with two permanent horizontal ducts, one commencing within 12 inches (300 mm) of the top and one commencing within 12 inches (300 mm) of the bottom of the enclosure. The horizontal ducts shall communicate directly with the outdoors. See Figure 18.

Each duct opening shall have a minimum free area of 1 square inch per 2,000 Btu/hr (1100 mm² per kW) of the aggregate input rating of all appliances installed in the enclosure.

When ducts are used, they shall be of the same cross sectional area as the free area of the openings to which they connect. The minimum dimension of rectangular air ducts shall be not less than 3 inches.

OUTDOOR AIR THROUGH TWO VERTICAL DUCTS

The illustrations shown in this section of the manual are a reference for the openings that provide fresh air into confined spaces only.

Do not refer to these illustrations for the purpose of vent installation.

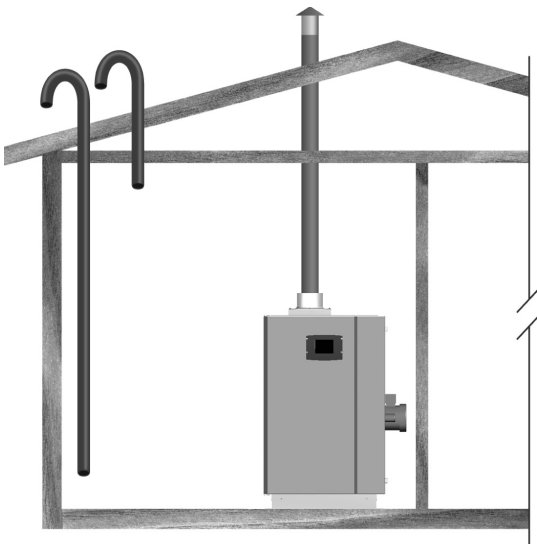

FIGURE 19. OUTDOOR AIR THROUGH TWO VERTICAL DUCTS

The confined space shall be provided with two permanent vertical ducts, one commencing within 12 inches (300 mm) of the top and one commencing within 12 inches (300 mm) of the bottom of the enclosure. The vertical ducts shall communicate directly with the outdoors. See Figure 19.

Each duct opening shall have a minimum free area of 1 square inch per 4,000 Btu/hr (550 mm² per kW) of the aggregate input rating of all appliances installed in the enclosure.

When ducts are used, they shall be of the same cross sectional area as the free area of the openings to which they connect. The minimum dimension of rectangular air ducts shall be not less than 3 inches.

AIR FROM OTHER INDOOR SPACES

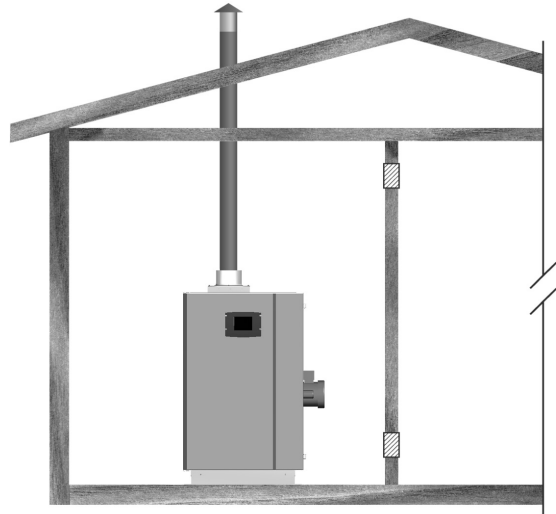

FIGURE 20. AIR FROM OTHER INDOOR SPACES

The confined space shall be provided with two permanent openings, one commencing within 12 inches (300 mm) of the top and one commencing within 12 inches (300 mm) of the bottom of the enclosure. See Figure 20.

Each opening shall communicate directly with an additional room(s) of sufficient volume so that the combined volume of all spaces meets the criteria for an Unconfined Space.

Each opening shall have a minimum free area of 1 square inch per 1,000 Btu/hr (1100 mm² per kW) of the aggregate input rating of all appliances installed in the enclosure. Each opening shall not be less than 100 square inches (645 cm²).

VENTING

⚠ WARNING

Fire and Breathing Hazard



The instructions in this section on venting the boiler must be followed to avoid choked combustion or recirculation of flue gases. Such conditions cause sooting or risks of fire and asphyxiation.



VENT INSTALLATION CONSIDERATIONS

This water heater can be vented using room air for intake combustion air, or direct vented so that all intake air for combustion comes from the outside through a sealed pipe. When installing this appliance as direct vent, use the recommended terminations in this section, refer to Page 27 till Page 30.

In cold climates any water vapor remaining in the flue gases will condense into a cloud of vapor at the point where the vent system exits the building. Special consideration is recommended, before locating the vent termination near walkways, windows and building entrances.

Direct venting into dead spaces such as alleys, atriums, and inside corners can cause recirculation of flue gases. Recirculation of flue gases will cause sooting, premature failure of the heat exchanger, and icing of the combustion air intake during severe cold weather. To prevent the recirculation of flue gases, maintain as much distance as possible between the combustion air intake and the exhaust vent terminal. Due to large volumes of flue gases, multiple water heater applications also require additional distance between the intake and the exhaust terminals.

This water heater must be vented with Polypropylene, PVC/CPVC or an UL approved AL 29-4C Stainless Steel venting material which are explained in the following pages. Vent sizing, installation and termination should be in accordance with this instruction manual.

All electrical power and gas must be turned off prior to any installation of the venting system.

GENERAL VENT INSTALLATION PROCEDURE

Prior to beginning the installation of the vent system, determine and obtain all parts required for the installation. Proper operation of the water heater and venting system is dependent upon use of all specified parts and installation techniques; both safety and proper performance of the system may suffer if instructions are not followed.

POLYPROPYLENE INSTALLATION:

All XWH water heaters are shipped with Polypropylene venting kits out of the factory. These kits are in separate cartons along with the water heater shipment. They must be assembled and installed on the water heater as shown in Figure 21 & Figure 22. Using Centrocerin is recommended as an assembly lube for venting. Application of Centrocerin resists movement between the vent legths and fittings. The vent pipes must also be properly supported. The kit also includes a PVC/CPVC adapter, which can be discarded and will only be required for PVC/CPVC vent installations. A condensate trap is also supplied with the venting kit and needs to be piped separately in the field.

PVC/CPVC INSTALLATION:

Installation must comply with local requirements and with the National Fuel Gas Code, ANSI Z223.1 for U.S. installations or CSA B149.1 for Canadian installations.

Refer to Table 12 on Page 36 for PVC/CPVC piping materials. PVC/CPVC Installation requires the use of factory supplied PVC/CPVC adapters.

All PVC vent pipes must be glued, properly supported, and the exhaust must be pitched a minimum of a 1/4 inch per foot back to the water heater (to allow drainage of condensate).

This water heater requires a special venting system. Use only the vent materials, primer, and cement specified in this manual to make the vent connections. Failure to follow this warning could result in fire, personal injury, or death.

NOTE: Make sure that for PVC venting installation, the first 10 feet (3 m) of vent must be CPVC and the set point temperature of the water heater must not exceed 200 °F.

STAINLESS STEEL INSTALLATION:

Installations must comply with applicable national, state, and local codes. Stainless steel vent systems must be listed as a UL-1738 approved system for the United States and a ULC-S636 approved system for Canada.

The factory supplied polypropylene vent kit will not adapt to stainless steel installation. For using the water heater with stainless steel, contact factory or pre-order the unit with stainless steel kit.

Installation of the approved AL 29-4C stainless steel venting material should adhere to the stainless steel vent manufacturer's installation instructions supplied with the vent system.

Refer to Table 13 and Table 14 on Page 36 for air intake and vent pipe sizes.

AIR INTAKE/VENT CONNECTIONS

1. **Air Intake Adapter:** Provides an inlet for combustion air directly to the unit from outdoors.
2. **Vent Outlet:** Provides an outlet for combustion gases to outdoors.

VENTING SYSTEM

This water heater may be installed in six separate orientations depending on the requirements of the building and the appliance. The installer must decide which method is most appropriate for each installation. These orientations are:

1. **Vertical Termination** - vertical vent termination through un-enclosed or enclosed areas with roof penetration, see Figure 23 on Page 28.
2. **Through-the-Wall Termination (TWT)** - horizontal vent termination directly through an outside wall, see Figure 24 on Page 28.
3. **Horizontal Direct Vent** - using TWT to exhaust flue products and PVC piping to bring combustion air to the water heater from the outside. See Figure 25 on Page 29 and Figure 28 on Page 30.
4. **Vertical Direct Vent** - using a vertical vent termination to exhaust flue products and PVC piping to bring combustion air to the water heater from outside, see Figure 26 on Page 29 and Figure 27 on Page 30.

SUPPLIED VENT KIT:

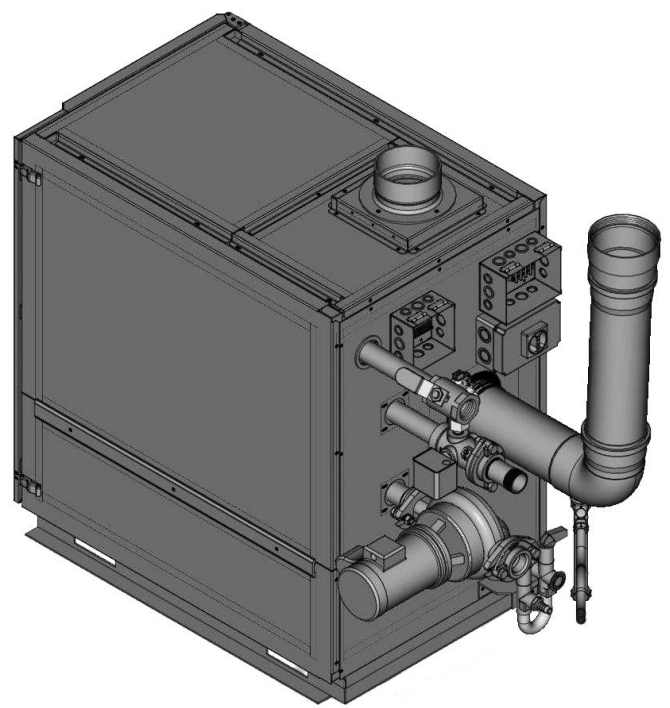
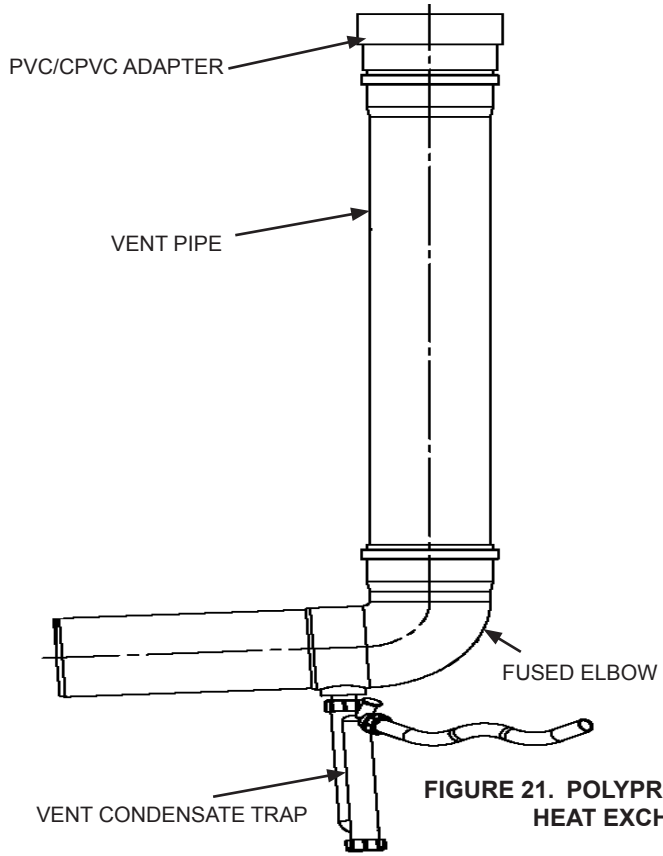

FIGURE 21. POLYPROPYLENE INSTALLATION: SINGLE HEAT EXCHANGER WATER HEATER

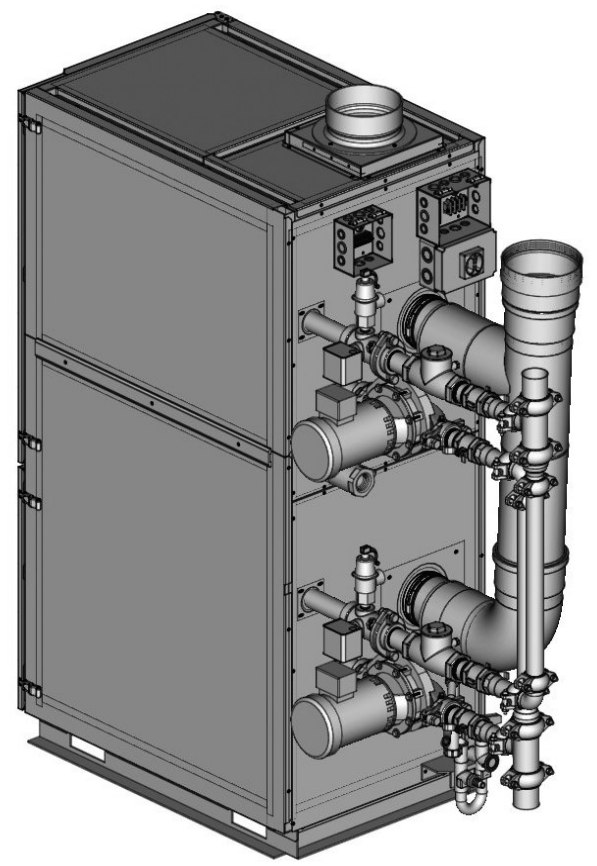
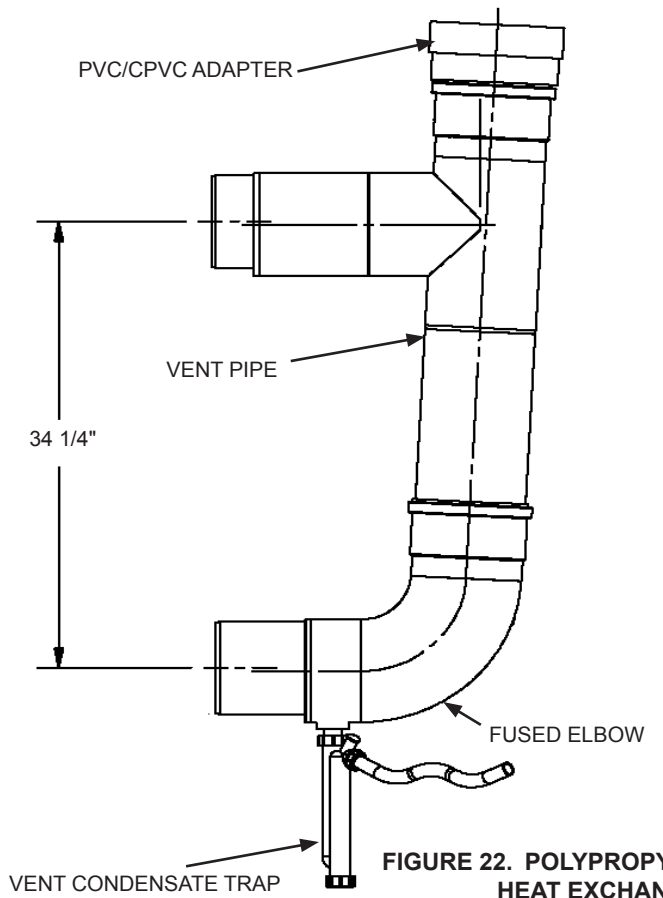

FIGURE 22. POLYPROPYLENE INSTALLATION: DOUBLE HEAT EXCHANGER WATER HEATER

AIR INLET PIPE MATERIALS

Make sure the air inlet pipe(s) are sealed. The acceptable air inlet pipe materials are:

- PVC/CPVC
- Polypropylene

The opening on the air intake box will readily accept PVC/CPVC pipes. If air intake is Polypropylene, an adapter (use the ones provided with exhaust kit) is required. Adapter part numbers:

SIZE	PART NUMBERS
6"	324400-000
8"	324401-000
10"	324402-000

Seal all joints and seams of the air inlet pipe using either Aluminum Foil Duct Tape meeting UL Standard 723 or 181A-P or a high quality UL Listed silicone sealant. Do not install seams of vent pipe on the bottom of horizontal runs.

Secure all joints with a minimum of 3 sheet metal screws or pop rivets. Apply Aluminum Foil Duct Tape or silicone sealant to all screws or rivets installed in the vent pipe.

Make sure that the air inlet pipes are properly supported.

The PVC/CPVC or Polypropylene air inlet pipe must be cleaned and sealed with the pipe manufacturer's recommended solvents and standard commercial pipe cement for the material used.

The PVC/CPVC or Polypropylene air inlet pipe should use a silicone sealant to ensure a proper seal at the water heater connection and the air intake adapter connection. Proper sealing of the air inlet pipe ensures that combustion air will be free of contaminants and supplied in proper volume.

REQUIREMENTS FOR INSTALLATION IN CANADA

1. Installations must be made with a vent pipe system certified to ULC-S636. IPEX is an approved vent manufacturer in Canada supplying vent material listed to ULC-S636.
2. The initial 3 feet (0.9 m) of plastic vent pipe from the water heater flue outlet must be readily accessible for visual inspection.
3. The components of the certified vent system must not be interchanged with other vent systems or unlisted pipe/fittings.

VENT AND AIR PIPE INSTALLATION

1. Measure from the water heater level to vent. Refer to the Table 13 on Page 36 for the allowable lengths.
2. Prepare pipes to the required lengths and deburr the inside and outside of the pipe ends. Chamfer outside the pipe end to ensure even cement distribution when joining.
3. Clean all pipe ends and fittings using a clean dry rag. (Moisture will retard curing and dirt or grease will prevent adhesion.)
4. Dry fit vent or air piping to ensure proper fit before assembling any joint. The pipe should go a third to two-thirds into the fitting to ensure proper sealing after cement is applied.
5. Priming and Cementing:
 - Handle pipes and fittings carefully to prevent contamination of surfaces.
 - Apply an even coat of primer to the fitting socket.
 - Apply an even coat of primer to the pipe end to approximately 1/2" beyond the socket depth.
 - Apply a second primer coat to the fitting socket.
 - While primer is still wet, apply an even coat of approved cement to the pipe equal to the depth of the fitting socket.
 - While primer is still wet, apply an even coat of approved cement to the fitting socket.
 - Apply a second coat of cement to the pipe.
 - While the cement is still wet, insert the pipe into the fitting, if possible twist the pipe a 1/4 turn as you insert it.

NOTE: If voids are present, sufficient cement was not applied and joint could be defective.

- Clear excess cement from the joint removing ring or beads as it will needlessly soften the pipe.

When a sidewall or vertical rooftop combustion air supply system is disconnected for any reason, the air inlet pipe must be resealed to ensure that combustion air will be free of contaminants and supplied in proper volume.

Failure to properly seal all joints and seams may result in flue gas recirculation, spillage of flue products and carbon monoxide emissions causing severe personal injury or death.

VENTING SUPPORTS

Care must be taken in the installation of the venting system that adequate support is maintained throughout the installation process. When extending more than 10 feet (3 m) vertically, vertical support kits are required once every 10 feet (3 m) of vertical run. Vertical support is also required immediately after any transition (elbow, tee, etc.) to vertical of over 10 feet (3 m) of run and after any offset in the vertical run.

The support brackets (supplied in the Vertical Support Kit) are to be securely fastened to a solid vertical member of the building using the appropriate fasteners; i.e., wood screws for wood framing, machine or tapping screws for structural steel or masonry anchors for solid masonry. The bracket should be located so that it will not interfere with any joints of the venting system. The bottom most support bracket should be located directly above the first transition from horizontal to vertical.

If a means of support for the brackets is not available and horizontal vent sections are present, install hanger straps (made from non-combustible material) as close to the points of transition as possible. If the horizontal portions of the vent and/or vent connector are longer than 6 feet (1.8 m), then install hanger straps every 6 feet (1.8 m) to support the connector.

Do not rivet or screw the straps to the conduit or otherwise puncture the conduit wall. Instead, wrap an extra loop of strap around the conduit to hold it in position, or attach the strap to the center screw of the double wall AL 29-4C® vent coupling, if applicable.

VERTICAL INSTALLATION REQUIREMENTS

1. The vent system must terminate at least 3 feet (0.9 m) and no more than 6 feet (1.8 m) above the roof line and no closer than 10 feet (3 m) from any wall or vertical structure. If the exhaust vent terminal is within 10 feet (3 m) of a wall or parapet, it must extend a minimum of 2 feet (0.6 m) above the wall or parapet, see Figure 23 on Page 28 and Figure 26 on Page 29.
2. For direct vent installations, the total distance of the vent system from the water heater vent connector to the vertical vent termination should not exceed 100 equivalent feet (30.5 m). Minimum vertical vent is 10 equivalent feet (3 m) for direct vent installations. Standard minimum vertical vent length is 10 feet (3 m). See Figure 23, Figure 26 thru Figure 28 for differences between standard and direct vent installations.
3. Maintain a minimum of 4 feet (1.2 m) separation between the air intake and the exhaust terminals.

HORIZONTAL INSTALLATION REQUIREMENTS

1. The vent system must terminate with the Through-the-Wall Termination (TWT) kits. Do not locate the terminal within 8 feet (2.4 m) of an inside corner of a building or adjacent to outside walls, shrubs or other such objects that may cause adverse wind conditions in the immediate area.
2. The TWT should be located not less than 12 inches (305 mm) above grade or, in geographical areas where snow accumulates, no less than 12 inches (305 mm) above anticipated snow line. Ensure that TWT is protected against blockage which may occur during ice buildup or snowstorms. The TWT should terminate at least 3 feet (0.9 m) above any forced air inlet within 10 feet (3 m), except when the forced air inlet is the combustion air intake of a direct vent appliance. The TWT should terminate at least 4 feet (1.2 m) below, 4 feet (1.2 m) horizontally from or 1 foot (305 mm) above any door, window or gravity air inlet into any building as provided in the current edition of the national fuel gas code ANSI Z223.1. In addition, a minimum clearance of 4 feet (1.2 m) horizontally from, and in no case above or below, unless the 4 feet (1.2 m) of horizontal distance is maintained from electric meters, gas meters, regulators and relief equipment.
3. This horizontal exhaust vent system must pitch upward toward the termination at 1/4 inch per foot (21 mm per meter).
4. The TWT is designed such that the building is protected from degradation by flue gas and condensate. However, if additional protection is desired, install against the wall a non-corrosive metal sheet under the TWT.
5. Due to the normal formation of water vapor in the combustion process, horizontal terminations must not be located over areas of pedestrian or vehicular traffic, (i.e., public walkways or over areas where condensate could create a nuisance or hazard). This is especially true in colder climates where ice buildup is likely to occur. A. O. Smith Corporation will not be held liable for any personal injury or property damage due to any dislodging of ice.

DIRECT VENT INSTALLATION REQUIREMENTS

The labels in the Direct Vent Kit must be affixed to the water heater in locations specified by the instruction sheet provided in the kit. The following are requirements for the Air-Intake Terminal (AIT):

1. The Air-Intake System (AIS) must terminate with the venting equipment provided with the water heater.
2. The AIT should not be located less than 3 feet (0.9 m) below any exhaust vent within 10 feet (3 m).
3. The total horizontal distance of the AIS from the water heater's Blower Adapter to the outside of the "AIT" should not be greater than 100 equivalent feet (30.5 m) of vent pipe nor less than 3 feet (0.9 m), including elbows.

MODELS (XWH)	RAIN CAP (PVC/CPVC)
1000	320884-000
1300	320884-001
1700	320884-001
2000	320884-001
2600	320884-001
3400	320884-002

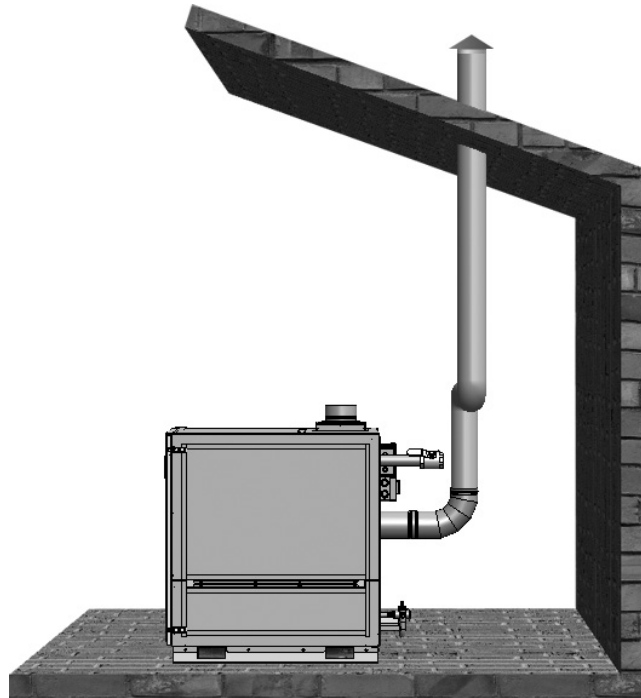

FIGURE 23. VERTICAL VENTING/ TERMINATION

MODELS (XWH)	TEE VENT TERMINATIONS (PVC/CPVC)	TEE VENT TERMINATIONS (POLYPROPYLENE)
1000	321765-000	324435-000
1300	321765-001	324435-001
1700	321765-001	324435-001
2000	321765-001	324435-001
2600	321765-001	324435-001
3400	321765-002	324435-002

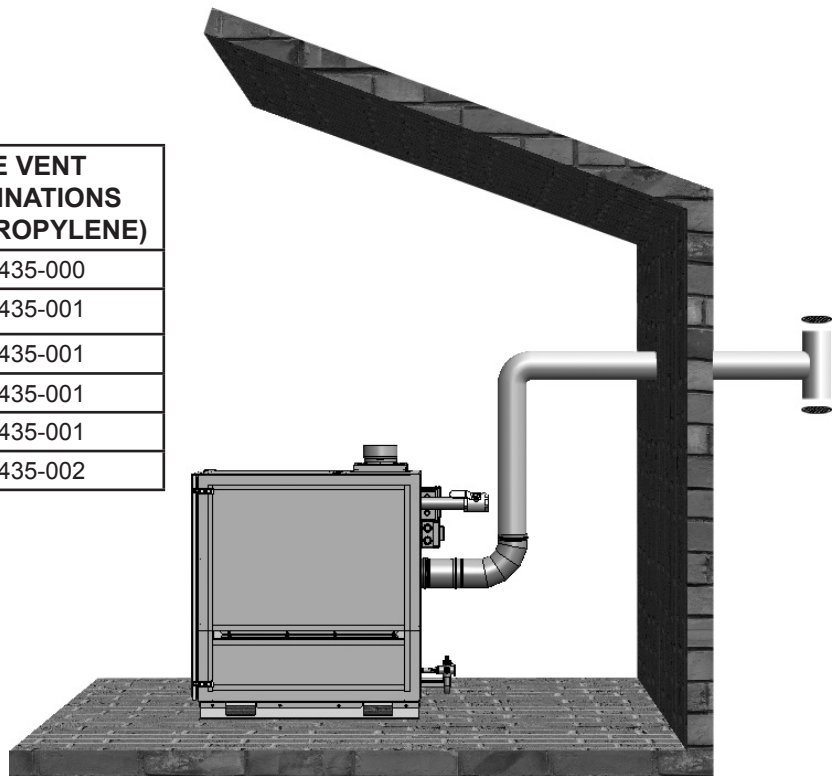

FIGURE 24. HORIZONTAL VENTING/ TERMINATION

MODELS (XWH)	TEE VENT TERMINATIONS (PVC/CPVC)	TEE VENT TERMINATIONS (POLYPROPYLENE)	AIR INTAKE ELBOW (PVC/CPVC)
1000	321765-000	324435-000	321764-000
1300	321765-001	324435-001	321764-000
1700	321765-001	324435-001	321764-001
2000	321765-001	324435-001	321764-001
2600	321765-001	324435-001	321764-001
3400	321765-002	324435-002	321764-002

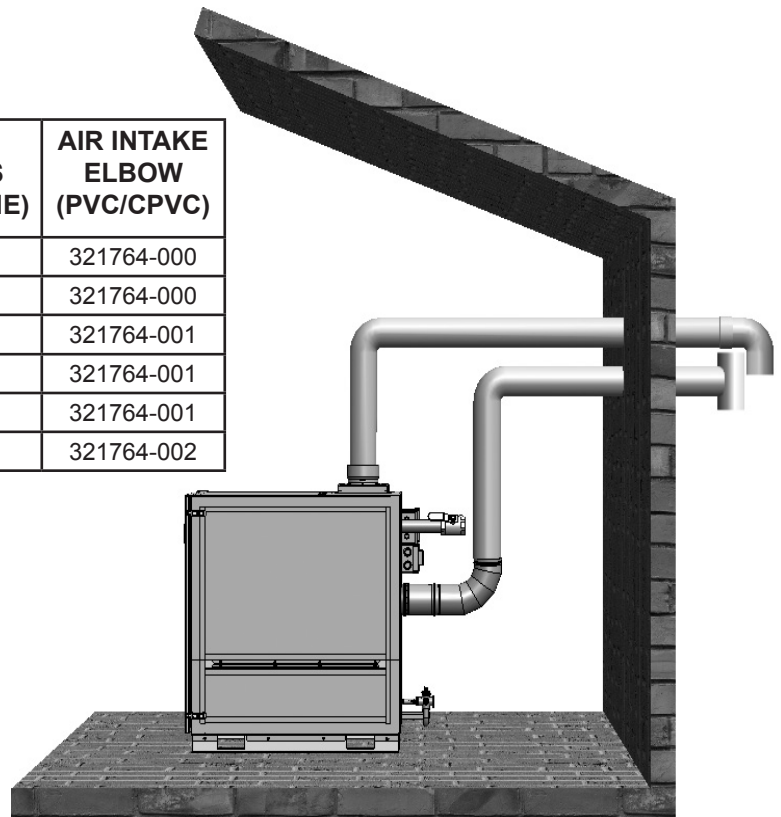

FIGURE 25. DIRECT VENT HORIZONTAL

MODELS (XWH)	RAIN CAP (PVC/CPVC)	AIR INTAKE ELBOW (PVC/CPVC)
1000	320884-000	321764-000
1300	320884-001	321764-000
1700	320884-001	321764-001
2000	320884-001	321764-001
2600	320884-001	321764-001
3400	320884-002	321764-002

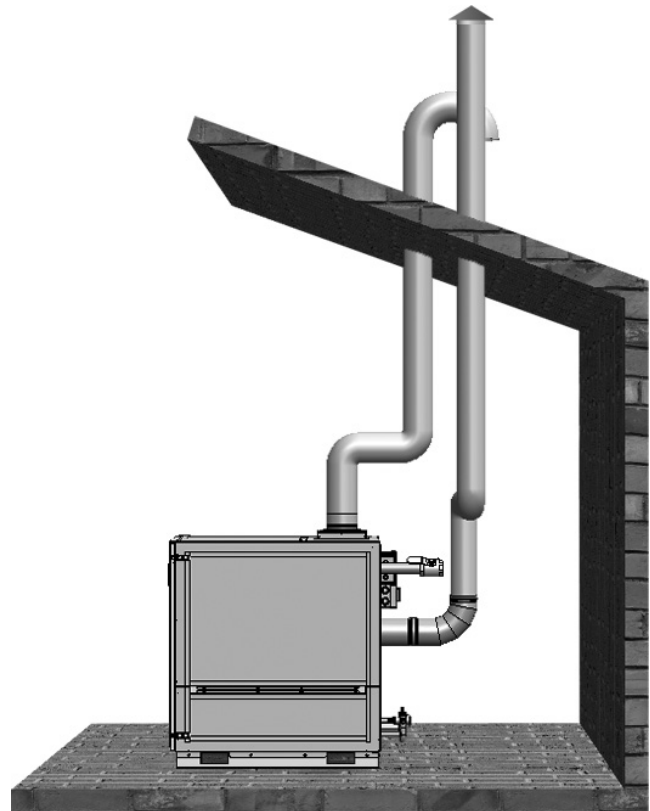

FIGURE 26. DIRECT VENT VERTICAL

MODELS (XWH)	RAIN CAP (PVC/CPVC)	AIR INTAKE ELBOW (PVC/CPVC)
1000	320884-000	321764-000
1300	320884-001	321764-000
1700	320884-001	321764-001
2000	320884-001	321764-001
2600	320884-001	321764-001
3400	320884-002	321764-002

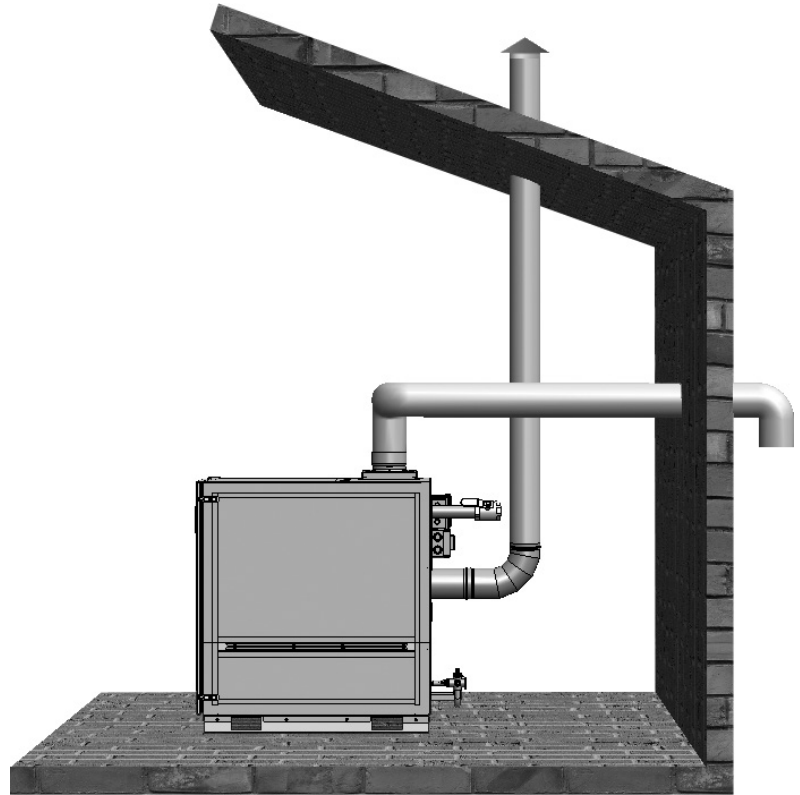

FIGURE 27. DIRECT VENT, VERTICAL VENT HORIZONTAL INTAKE

MODELS (XWH)	TEE VENT TERMINATION (PVC/CPVC)	TEE VENT TERMINATIONS (POLYPROPYLENE)	AIR INTAKE ELBOW (PVC/CPVC)
1000	321765-000	324435-000	321764-000
1300	321765-001	324435-001	321764-000
1700	321765-001	324435-001	321764-001
2000	321765-001	324435-001	321764-001
2600	321765-001	324435-001	321764-001
3400	321765-002	324435-002	321764-002

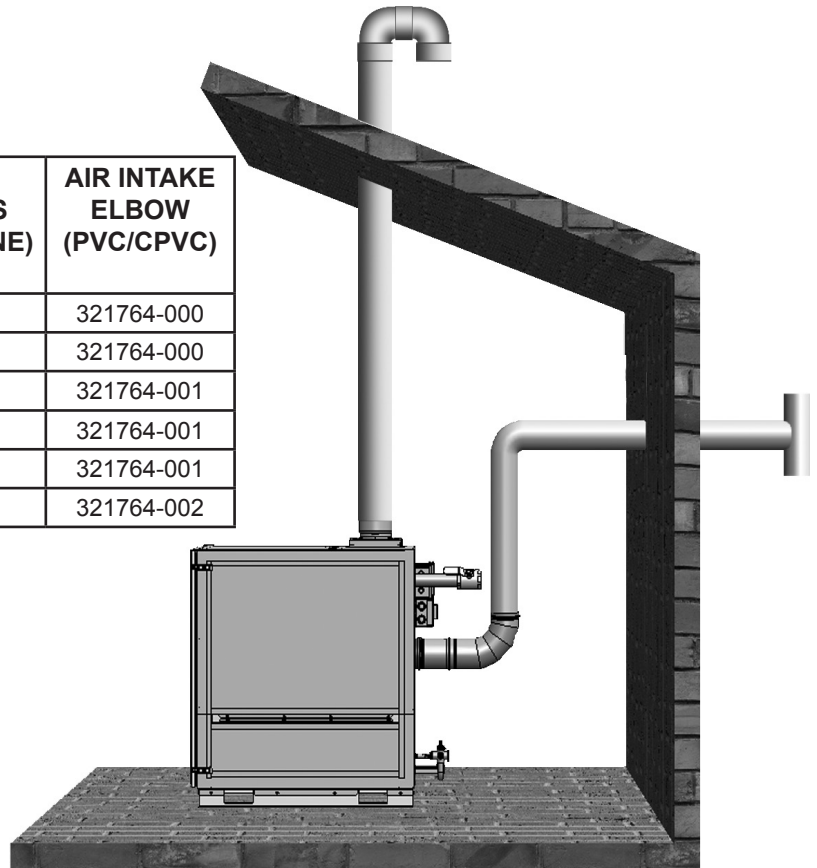

FIGURE 28. DIRECT VENT, HORIZONTAL VENT VERTICAL INTAKE

TERMINATION CLEARANCES SIDEWALL POWER VENT

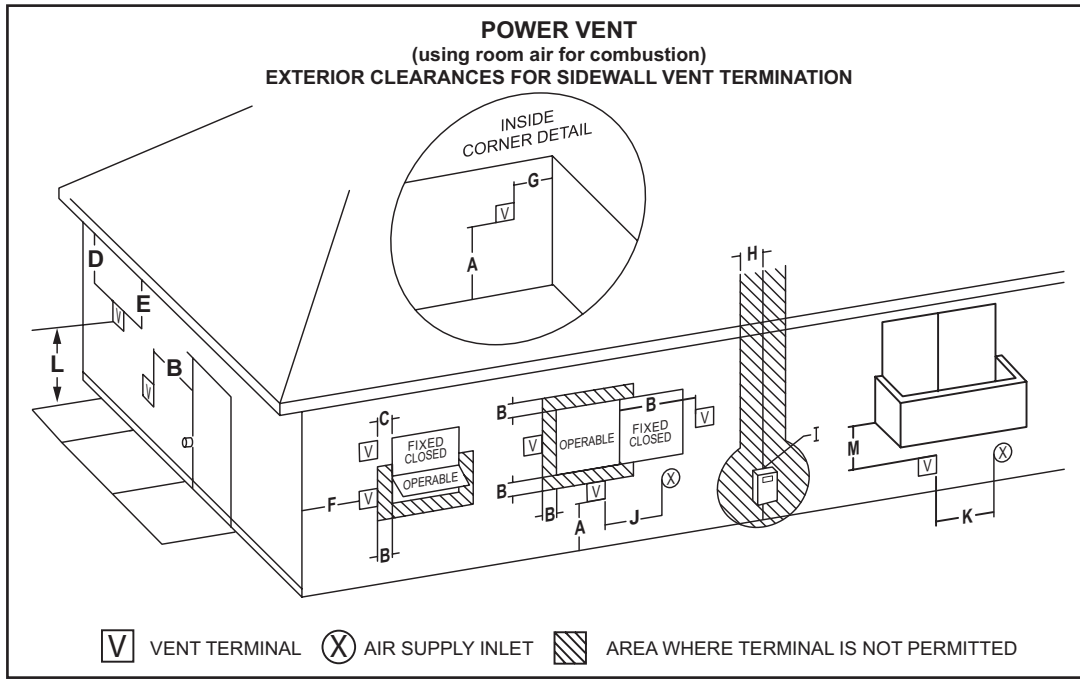

FIGURE 29. POWER VENT

Vent terminal clearances for “Power Vent” installations. Power Vent configurations use room air for combustion.

	CANADIAN INSTALLATIONS ¹		US INSTALLATIONS ²		CANADIAN INSTALLATIONS ¹		US INSTALLATIONS ²	
A	Clearance above grade, veranda, porch, deck or balcony	12 inches (30 cm)	12 inches (30 cm)	H	Clearance to each side of center line extended above meter/regulator assembly	3 feet (91 cm) within a height 15 feet (4.5 m) above the meter/regulator assembly	3 feet (91 cm) within a height 15 feet (4.5 m) above the meter/regulator assembly*	
B	Clearance to window or door that may be opened	6 inches (15 cm) for appliances up to 10,000 Btu/hr (3 kW), 12 inches (30 cm) for appliances between 10,000 Btu/hr (3 kW) and 100,000 Btu/hr (30 kW), 36 inches (91 cm) for appliances above 100,000 Btu/hr (30 kW)	4 feet (1.2 m) below or to side of opening; 1 foot (30 cm) above opening	I	Clearance to service regulator vent outlet	3 feet (91 cm)	3 feet (91 cm)*	
C	Clearance to permanently closed window	12 inches (30 cm)*	12 inches (30 cm)*	J	Clearance to a non mechanical air supply inlet into building or combustion air inlet to any other appliance	6 inches (15 cm) for appliances up to 10,000 Btu/hr (3 kW), 12 inches (30 cm) for appliances between 10,000 Btu/hr (3 kW) and 100,000 Btu/hr (30kW), 36 inches (91cm) for appliances above 100,000 Btu/hr (30 kW)	4 feet (1.2 m) below or to side of opening; 1 foot (30 cm) above opening.	
D	Vertical clearance to ventilated soffit located above the terminal within a horizontal distance of 2 feet (61 cm) from the center line of the terminal	12 inches (30 cm)*	12 inches (30 cm)*	K	Clearance to a mechanical air supply inlet	6 feet (1.83 m)	3 feet (91 cm) above if within 10 feet (3 m) horizontally	
E	Clearance to unventilated soffit	12 inches (30 cm)*	12 inches (30 cm)*	L	Clearance above paved sidewalk or paved driveway located on public property	7 feet (2.13 m)†	7 feet (2.13 m)	
F	Clearance to outside corner	2 feet (60 cm)*	2 feet (60 cm)*	M	Clearance under veranda, porch, deck, or balcony	12 inches (30 cm) ‡	12 inches (30 cm) ‡	
G	Clearance to inside corner	8 feet (2.44 m)*	8 feet (2.44 m)*					

¹ In accordance with the current CSA B149.1, Natural Gas and Propane Installation Code.

² In accordance with the current ANSI Z223.1/NFPA 54, National Fuel Gas Code.

† A vent shall not terminate directly above a sidewalk or paved driveway that is located between two single family dwellings and serves both dwellings.

‡ Permitted only if veranda, porch, deck, or balcony is fully open on a minimum of two sides beneath the floor.

* Clearance in accordance with local installation codes and the requirements of the gas supplier and the manufacturer’s installation instructions.

TERMINATION CLEARANCES SIDEWALL DIRECT VENT

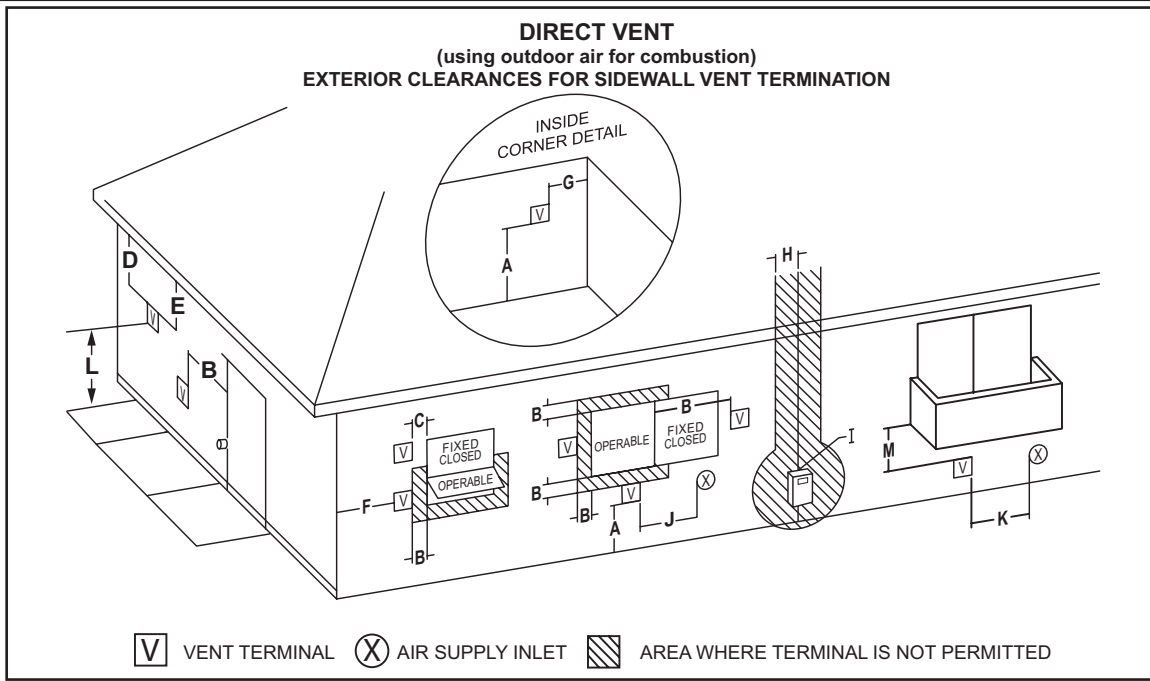

FIGURE 30. DIRECT VENT

Vent terminal clearances for “Direct Vent” installations. Direct Vent configurations use outdoor air for combustion.

		CANADIAN INSTALLATIONS ¹		US INSTALLATIONS ²		CANADIAN INSTALLATIONS ¹		US INSTALLATIONS ²	
A	Clearance above grade, veranda, porch, deck or balcony	12 inches (30 cm)	12 inches (30 cm)	H	Clearance to each side of center line extended above meter/regulator assembly	3 feet (91 cm) within a height 15 feet (4.5 m) above the meter/regulator assembly	3 feet (91 cm) within a height 15 feet (4.5 m) above the meter/regulator assembly*		
B	Clearance to window or door that may be opened	6 inches (15 cm) for appliances up to 10,000 Btu/hr (3 kW), 12 inches (30 cm) for appliances between 10,000 Btu/hr (3 kW) and 100,000 Btu/hr (30 kW), 36 inches (91 cm) for appliances above 100,000 Btu/hr (30 kW)	6 inches (15 cm) for appliances up to 10,000 Btu/hr (3 kW), 9 inches (23 cm) for appliances between 10,000 Btu/hr (3 kW) and 50,000 Btu/hr (15 kW), 12 inches (30 cm) for appliances above 50,000 Btu/hr (15 kW)	I	Clearance to service regulator vent outlet	3 feet (91 cm)	3 feet (91 cm)*		
C	Clearance to permanently closed window	6 inches (15 cm)*	6 inches (15 cm)*	J	Clearance to a non mechanical air supply inlet into building or combustion air inlet to any other appliance	6 inches (15 cm) for appliances up to 10,000 Btu/hr (3 kW), 12 inches (30 cm) for appliances between 10,000 Btu/hr (3 kW) and 100,000 Btu/hr (30 kW), 36 inches (91 cm) for appliances above 100,000 Btu/hr (30 kW)	6 inches (15 cm) for appliances up to 10,000 Btu/hr (3 kW), 9 inches (23 cm) for appliances between 10,000 Btu/hr (3 kW) and 50,000 Btu/hr (15 kW), 12 inches (30 cm) for appliances above 50,000 Btu/hr (15 kW)		
D	Vertical clearance to ventilated soffit located above the terminal within a horizontal distance of 2 feet (61 cm) from the center line of the terminal	12 inches (30 cm)*	12 inches (30 cm)*	K	Clearance to a mechanical air supply inlet	6 feet (1.83 m)	3 feet (91 cm) above if within 10 feet (3 m) horizontally		
E	Clearance to unventilated soffit	12 inches (30 cm)*	12 inches (30 cm)*	L	Clearance above paved sidewalk or paved driveway located on public property	7 feet (2.13 m)†	7 feet (2.13 m)*		
F	Clearance to outside corner	2 feet (60 cm)*	2 feet (60 cm)*	M	Clearance under veranda, porch, deck, or balcony	12 inches (30 cm) ‡	12 inches (30 cm) ‡*		
G	Clearance to inside corner	8 feet (2.44 m)*	8 feet (2.44 m)*						

¹ In accordance with the current CSA B149.1, Natural Gas and Propane Installation Code.

² In accordance with the current ANSI Z223.1/NFPA 54, National Fuel Gas Code.

† A vent shall not terminate directly above a sidewalk or paved driveway that is located between two single family dwellings and serves both dwellings.

‡ Permitted only if veranda, porch, deck, or balcony is fully open on a minimum of two sides beneath the floor.

* Clearance in accordance with local installation codes and the requirements of the gas supplier and the manufacturer’s installation instructions.

INSTALLATION REQUIREMENTS FOR THE COMMONWEALTH OF MASSACHUSETTS

For all side wall terminated, horizontally vented power vent, direct vent, and power direct vent gas fueled water heaters installed in every dwelling, building or structure used in whole or in part for residential purposes, including those owned or operated by the Commonwealth and where the side wall exhaust vent termination is less than seven (7) feet above finished grade in the area of the venting, including but not limited to decks and porches, the following requirements should be satisfied:

INSTALLATION OF CARBON MONOXIDE DETECTORS At the time of installation of the side wall horizontal vented gas fueled equipment, the installing plumber or gasfitter should observe that a hard wired carbon monoxide detector with an alarm and battery back-up is installed on the floor level where the gas equipment is to be installed. In addition, the installing plumber or gasfitter should observe that a battery operated or hard wired carbon monoxide detector with an alarm is installed on each additional level of the dwelling, building or structure served by the sidewall horizontal vented gas fueled equipment. It should be the responsibility of the property owner to secure the services of qualified licensed professionals for the installation of hard wired carbon monoxide detectors.

In the event that the side wall horizontally vented gas fueled equipment is installed in a crawl space or an attic, the hard wired carbon monoxide detector with alarm and battery back-up may be installed on the next adjacent floor level.

In the event that the requirements of this subdivision can not be met at the time of completion of installation, the owner should have a period of thirty (30) days to comply with the above requirements provided that during said thirty (30) day period, a battery operated carbon monoxide detector with an alarm should be installed.

APPROVED CARBON MONOXIDE DETECTORS Each carbon monoxide detector as required in accordance with the above provisions should comply with NFPA 720 and be ANSI/UL 2034 listed and CSA certified.

SIGNAGE A metal or plastic identification plate should be permanently mounted to the exterior of the building at a minimum height of eight (8) feet above grade directly in line with the exhaust vent terminal for the horizontally vented gas fueled heating appliance or equipment. The sign should read, in print size no less than one-half (1/2) inch in size, **"GAS VENT DIRECTLY BELOW. KEEP CLEAR OF ALL OBSTRUCTIONS."**

INSPECTION The state or local gas inspector of the side wall horizontally vented gas fueled equipment should not approve the installation unless, upon inspection, the inspector observes carbon monoxide detectors and signage installed in accordance with the provisions of 248 CMR 5.08(2)(a) 1 through 4.

EXEMPTIONS: The following equipment is exempt from 248 CMR 5.08(2)(a)1 through 4:

1. The equipment listed in Chapter 10 entitled "Equipment Not Required To Be Vented" in the most current edition of NFPA 54 as adopted by the Board; and
2. Product Approved side wall horizontally vented gas fueled equipment installed in a room or structure separate from the dwelling, building, or structure used in whole or in part for residential purposes.

MANUFACTURER REQUIREMENTS - GAS EQUIPMENT VENTING SYSTEM PROVIDED When the manufacturer of Product Approved side wall horizontally vented gas equipment provides a venting system design or venting system components with the equipment, the instructions provided by the manufacturer for installation of the equipment and the venting system should include:

1. Detailed instructions for the installation of the venting system design or the venting system components; and
2. A complete parts list for the venting system design or venting system.

MANUFACTURER REQUIREMENTS - GAS EQUIPMENT VENTING SYSTEM NOT PROVIDED When the manufacturer of a Product Approved side wall horizontally vented gas fueled equipment does not provide the parts for venting the flue gases, but identifies "special venting systems," the following requirements should be satisfied by the manufacturer:

1. The referenced "special venting system" instructions should be included with the appliance or equipment installation instructions; and
2. The "special venting systems" should be Product Approved by the Board, and the instructions for that system should include a parts list and detailed installation instructions.

A copy of all installation instructions for all Product Approved side wall horizontally vented gas fueled equipment, all venting instructions, all parts lists for venting instructions, and/or all venting design instructions should remain with the appliance or equipment at the completion of the installation.

DIRECT VENT: HORIZONTAL TERMINATION

Gas vent extending through an exterior wall must not terminate adjacent to a wall or below building extensions such as eaves, parapets, balconies, or decks. Failure to comply could result in severe personal injury, death, or substantial property damage.

Installation must comply with local requirements and with the National Fuel Gas Code, ANSI Z223.1 for U.S. installations or CSA B149.1 for Canadian installations.

VENT/AIR TERMINATION LOCATIONS:

Follow these guidelines for locating the vent/air terminations:

1. Make sure the total length of piping for vent or air do not exceed the limits mentioned in Table 13 and Table 14 on Page 36.
2. Consider the surroundings when terminating the vent and air:
 - While positioning the vent termination, ensure vapors will not damage nearby shrubs, plants or air conditioning equipment.
 - The flue products will form a noticeable plume as they condense in cold air. Avoid areas where the plume could obstruct window views.
 - Prevailing winds could cause freezing of condensate and water/ice buildup where flue products impinge on building surfaces or plants.
 - Do not allow accidental contact of flue products with people or pets.
 - Do not locate the terminations near building corners, near adjacent buildings or surfaces, window wells, stairwells, alcoves, courtyards, or other recessed areas, where wind eddies could affect performance or cause recirculation .
 - Sidewall vent and air inlet terminations must terminate in the same pressure zone.
 - Do not terminate above any door or window, where condensate can freeze, causing ice formations.
 - Locate or monitor the vent to prevent condensate damage to exterior finishes.

3. The air piping must terminate in a down-turned elbow, using a mesh screen. This setup will avoid recirculation of flue products into the combustion air stream. See Figure 31.
4. The vent piping must terminate with a Tee pointed upwards and away from the air inlet. See Figure 31.
5. Maintain clearances as shown in Figure 31 and Figure 32. Vent must terminate:

- At least 6 feet (1.8 m) from adjacent walls.
- No closer than 12 inches (305 mm) below roof overhang.
- At least 7 feet (2.1 m) above any public walkway.
- At least 3 feet (0.9 m) above any forced air intake within 10 feet (3 m).
- No closer than 12 inches (305 mm) below or horizontally from any door or window or any other gravity air inlet.

Air inlet must terminate at least 12 inches (305 mm) above grade or snow line; at least 12 inches (305 mm) below the vent termination; and the vent pipe must not extend more than 24 inches (610 mm) vertically outside the building as shown in Figure 31 and Figure 32.

Do not terminate closer than 4 feet (1.2 m) horizontally from any electric meter, gas meter, regulator, relief valve, or other equipment. Never terminate above or below any of these within 4 feet (1.2 m) horizontally.

6. Locate terminations so they are not likely to be damaged by foreign objects, such as stones or balls, or subject to buildup of leaves or sediment.

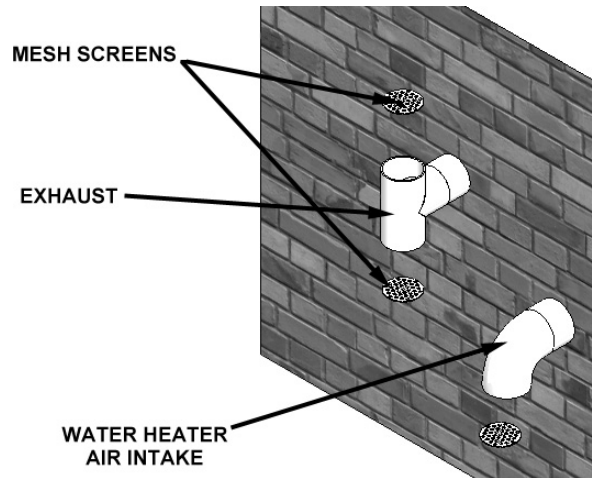

FIGURE 31. AIR/VENT TERMINATION - HORIZONTAL

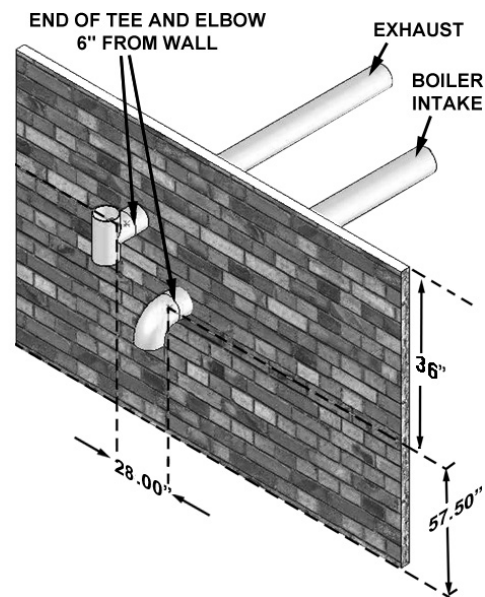

FIGURE 32. HORIZONTAL CLEARANCES - AIR/VENT TERMINATION

DIRECT VENTING: VERTICAL TERMINATION

Installation must comply with local requirements and with the National Fuel Gas Code, ANSI Z223.1 for U.S. installations or CSA B149.1 for Canadian installations.

VENT/AIR TERMINATION LOCATIONS:

Follow these guidelines for locating the vent/air terminations:

1. Make sure the total length of piping for vent or air do not exceed the limits mentioned in Table 13 and Table 14 on Page 36.
2. The vent must terminate at least 3 feet (0.9 m) above the highest place in which the vent penetrates the roof and at least 2 feet (0.6 m) above any part of a building within 10 feet (3 m) horizontal.
3. The air piping must terminate in a down-turned 180° elbow, using a mesh screen.
4. The vent piping must terminate in an up-turned rain cap as shown in Figure 33. When the vent termination uses a rain cap as illustrated in Figure 33, maintain at least 36" (914 mm) above the air inlet.
5. Locate terminations so they are not likely to be damaged by foreign objects, such as stones or balls, or subject to buildup of leaves or sediment and also not blocked or restricted by snow accumulation.
6. If installing both intake air and vent piping in a Direct Vent configuration vertically through the roof; ensure that all exterior vertical clearance requirements shown in Figure 35 are being maintained. These clearances and those cited by local and national codes must be maintained.

NOTE: On flat roof installations the intake air and the vent terminations must be a minimum of 24 inches (60 cm) above any parapet, vertical wall or structure within 10 feet (3 m) horizontally. See Figure 35.

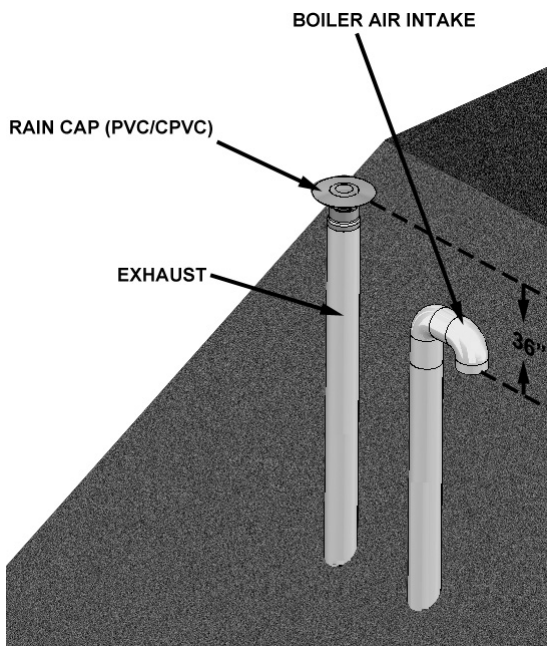

FIGURE 33. PVC/CPVC AIR/VENT TERMINATION - VERTICAL

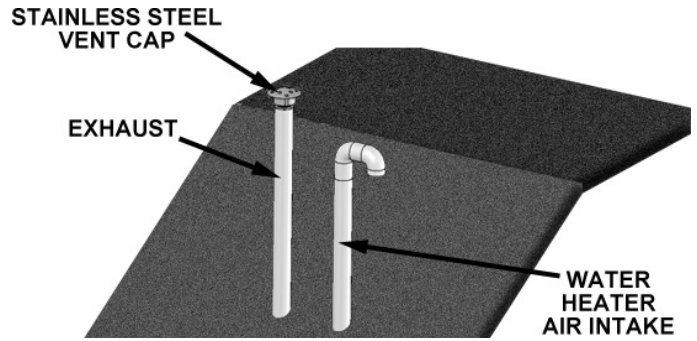

FIGURE 34. STAINLESS STEEL AIR/VENT TERMINATION - VERTICAL

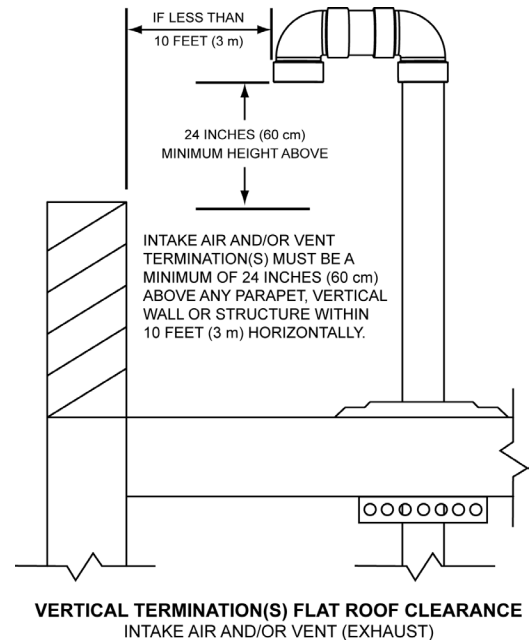

FIGURE 35. VERTICAL TERMINATION - FLAT ROOF CLEARANCES

PREPARE ROOF/WALL PENETRATIONS

1. Air pipe penetration:

Cut a hole for the air pipe. Size the air pipe hole as close as desired to the air pipe outside diameter.

2. Vent pipe penetration:

Cut a hole for the vent pipe. For either combustible or noncombustible construction, size the vent pipe hole with at least a 1/2 inch clearance around the vent pipe outer diameter:

- 7½ inch (178 mm) hole for 6 inch (152 mm) vent pipe
- 8½ inch (203 mm) hole for 7 inch (178 mm) vent pipe

Insert a galvanized metal thimble in the vent pipe hole (when required by local codes).

3. Space the air and vent holes to provide the minimum spacing shown in Figure 33 and Figure 34.
4. Follow all local codes for isolation of vent pipe when passing through floors, ceilings, and roofs.
5. Provide flashing and sealing boots sized for the vent pipe and air pipe.

TABLE 12. PVC, VENT PIPE, AND FITTINGS

ALL VENT PIPE MATERIALS AND FITTINGS MUST COMPLY WITH THE FOLLOWING:			
ITEM	MATERIAL	STANDARDS FOR INSTALLATION IN:	
		UNITED STATES	CANADA
Vent pipe and fittings	PVC schedule 40	ANSI/ASTM D1785	PVC, CPVC and Polypropylene venting must be ULC-S636 Certified.
	CPVC schedule 40/80	ANSI/ASTM F441	
	Polypropylene	UL 1738	
Pipe cement/primer	PVC	ANSI/ASTM D2564	ULC-S636 Certified.
	CPVC	ANSI/ASTM F493	

NOTICE: DO NOT USE CELLULAR (FOAM) CORE PIPE

TABLE 13. DIRECT VENT ALLOWABLE AIR/VENT LENGTHS

MODELS (XWH)	AIR INTAKE DIAMETER (INCH)	AIR INTAKE MIN. LENGTH FEET (M)	AIR INTAKE MAX. LENGTH FEET (M)	VENT DIAMETER (INCH)	VENT MIN. LENGTH FEET (M)	VENT MAX. LENGTH FEET (M)
1000	6	12 (3.7)	100 (30.5)	6	10 (3)	100 (30.5)
1300	6	12 (3.7)	100 (30.5)	8	10 (3)	100 (30.5)
1700	8	12 (3.7)	100 (30.5)	8	10 (3)	100 (30.5)
2000	8	12 (3.7)	100 (30.5)	8	10 (3)	100 (30.5)
2600	8	12 (3.7)	100 (30.5)	8	10 (3)	100 (30.5)
3400	10	12 (3.7)	100 (30.5)	10	10 (3)	100 (30.5)

TABLE 14. ROOM AIR ALLOWABLE VENT LENGTHS

MODELS (XWH)	VENT DIAMETER (INCH)	VENT MIN. LENGTH FEET (M)	VENT MAX. LENGTH FEET (M)
1000	6	10 (3)	100 (30.5)
1300	8	10 (3)	100 (30.5)
1700	8	10 (3)	100 (30.5)
2000	8	10 (3)	100 (30.5)
2600	8	10 (3)	100 (30.5)
3400	10	10 (3)	100 (30.5)

NOTE: When determining equivalent combustion air and vent length, add 10 feet (3 m) for each 90° elbow and 5 feet (1.5 m) for each 45° elbow. The Vent Max. Length does not include appliance elbows and adapters shipped with the unit.

TABLE 15. COMPLETE VENTING SYSTEM

VENT MATERIAL	START-BASE VENT		FIELD VENT LENGTHS & FITTINGS		TERMINATIONS & RAIN CAPS	
	INTAKE	EXHAUST	INTAKE	EXHAUST	INTAKE	EXHAUST
Polypropylene Venting	Air Intake Box (Adapter required to install Polypropylene pipes, can use Adapter discarded from exhaust).	Use Polypropylene Kit shipped with the unit, Discard PVC/CPVC Adapter or use it with Air Intake for Direct Vent applications.	Use Polypropylene pipes and fittings.	Use Polypropylene pipes and fittings.	Polypropylene 90° elbows.	Polypropylene Tee.
PVC/CPVC Venting	Air Intake Box will readily fit the PVC/CPVC pipes.	Use both Polypropylene Kit + PVC/CPVC Adapter (shipped with the unit).	Use PVC/CPVC pipes and fittings.	Use PVC/CPVC pipes and fittings.	PVC 90° elbows with wire mesh.	PVC Tee with wire mesh/ Rain Caps.
Stainless Steel Venting	Adapter required to fit to the Air Intake Box.	Pre-order unit with Stainless Steel Factory Kit.	Use Stainless Steel pipes and fittings.	Use Stainless Steel pipes and fittings.	Adapter required + PVC 90° elbows with wire mesh.	Adapter required + PVC Tee with wire mesh/ Rain Caps.

CONDENSATE DISPOSAL

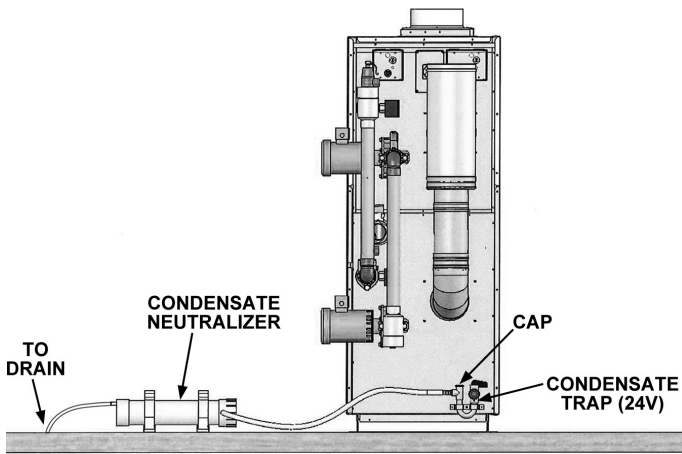

FIGURE 36. CONDENSATE DISPOSAL SYSTEM

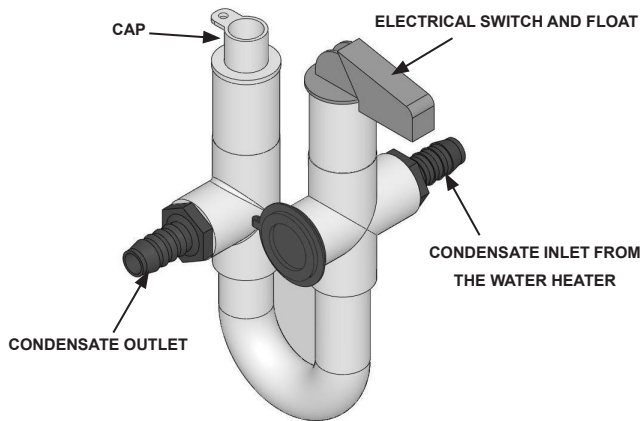

FIGURE 37. CONDENSATE TRAP

CONDENSATE TRAP

Installation of the Condensate Trap must conform with the instructions in this manual and local building codes. Condensate Neutralizer Kits are available. Contact your distributor or Service Agency. Do not remove, modify or alter the factory installed condensate trap. Install a commercially available neutralizing kit if required by the local codes.

The water heater is factory fitted with a 24V condensate trap connected to the controller. For safety reasons, if the condensate drain is blocked, the control system will turn off all the firing burners and bring the water heater to a safe shut down. If there is an air blockage in the line, vent out the air by removing the cap. Cap acts as an air vent for releasing any air block on down stream condensate line. Flexible silicon hose connect from the trap through the Condensate Neutralizer to the drain.

Due to the highly efficient operation of this unit, condensate is formed during operation and must be removed by the condensate drain systems. Inspect the condensate drains and tubes at least once a month and insure they will allow the free flow of condensate at all times. The system must be inspected more frequently in cold weather if the drain system is located in an area, such as along the floor, where freezing temperatures are likely to occur. The condensate drain system must be protected against freezing. Contact a qualified service agent to inspect and correct the condition if freezing of the condensate lines is a problem.

CONDENSATE NEUTRALIZER

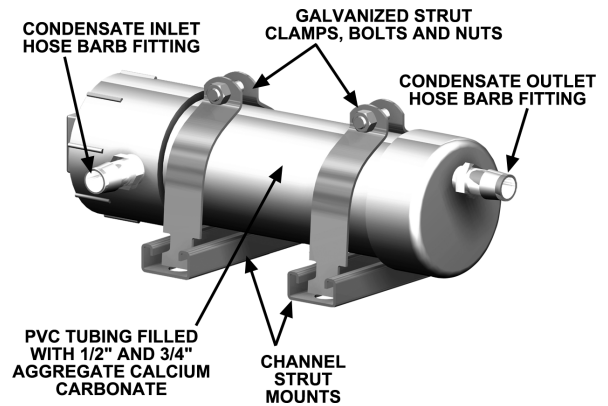

FIGURE 38. CONDENSATE NEUTRALIZER

The condensate drains from the water heater have pH levels between 4.3 and 5.0. The pH measurement of a fluid is an indicator of the acidity or alkalinity. Neutral fluids have pH of 7.0. Acid fluids have pH below 7. Some local codes may require the use of a condensate neutralizer to raise the pH level of the condensate leaving the water heater. The condensate neutralizer be must installed between the water heater and the drain and must be installed lower than the outlet of the condensate trap as shown in Figure 36. The Condensate Neutralizer Kit model must be selected with respect to the water heater's output as mentioned in the Table 16.

TABLE 16. CONDENSATE NEUTRALIZER KIT MODELS

MODELS (XWH)	A. O. SMITH CONDENSATE NEUTRALIZER KIT NUMBERS
1000	9007961005
1300	9007962005
1700	9007962005
2000	9007962005
2600	9007963005
3400	9007963005

GAS SUPPLY CONNECTIONS

GAS SUPPLY PIPE CONNECTIONS

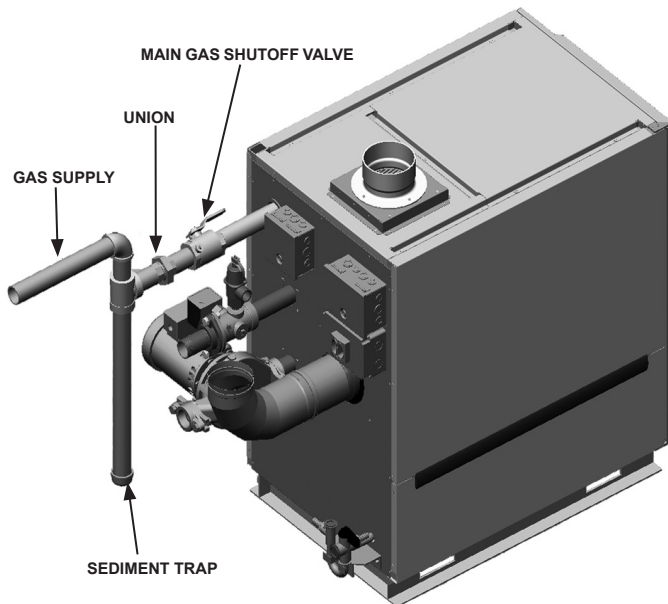

FIGURE 39. GAS SUPPLY PIPING

1. Make sure to install ground joint union for servicing.

In Canada – When using manual main shutoff to support the weight of the piping with valves, ensure that it is identified by the installer.

2. Install sediment trap per NFPA 54 for US and CAN B149.1 for Canada.
3. Support the piping with hangers, not by the water heater or its accessories. The gas valve and blower will not support the weight of the piping. Failure to comply could result in severe personal injury, death, or substantial property damage.
4. Purge all air from the gas supply piping.
5. Before setting the water heater in operation, check the water heater and its gas connection for leaks.
 - Disconnect the water heater from the gas supply piping system during any pressure testing, at a test pressure in excess of 1/2 PSIG (3.5 kPa)
 - The water heater must be isolated from the gas supply piping system by closing a manual shutoff valve during any pressure testing, at test pressures equal to or less than 1/2 PSIG (3.5 kPa).

Do not check for gas leaks with an open flame, instead use the bubble test. Failure to use the bubble test or check for gas leaks can cause severe personal injury, death, or substantial property damage.

6. Use pipe sealing compound compatible with propane gases. Apply sparingly only to male threads of the pipe joints so that pipe dope does not block gas flow.

Failure to apply pipe sealing compound as detailed in this manual can result in severe personal injury, death, or substantial property damage.

7. Make sure the maximum inlet gas pressure do not exceed the value specified. Minimum value specified is for input adjustment only.

Make sure to use two wrenches when tightening gas piping at the water heater, using one wrench to prevent the water heater gas line connection from turning. Failure to support the water heater gas connection pipe to prevent it from turning could damage gas line components. Do not use wrench on valve body as damage would occur.

GAS PRESSURE REQUIREMENTS

The maximum allowable gas supply pressure for this water heater is 14 inches w.c. (3.5 kPa). Install a positive lock-up gas pressure regulator in the gas supply line if inlet gas pressure can exceed 14 inches w.c. (3.5 kPa) at any time.

If a positive lock-up regulator is required follow these instructions:

1. Positive lock-up gas pressure regulators must be rated at or above the input Btu/hr rating of the water heater they supply.
2. Positive lock-up gas pressure regulator(s) should be installed no closer than 3 feet (0.9 m) and no farther than 8 feet (2.4 meters) from the water heater's inlet gas connection.
3. After installing the positive lock-up gas pressure regulator(s), an initial nominal supply pressure setting of 7 inches w.c. (1.7 kPa) while the water heater is operating is recommended and will generally provide good water heater operation. Some addition adjustment maybe required later to maintain a steady gas supply pressure.
4. When installing multiple water heaters in the same gas supply system it is recommended that individual positive lock-up gas pressure regulators be installed at each unit.

PIPE SIZES FOR PROPANE GAS

Make sure to contact the gas supplier for pipe sizes, tanks, and 100% lockup gas pressure regulator.

PURGING GAS LINE

Gas line purging is required with new piping or systems in which air has entered. Gas purging should be performed per NFPA 54 for US and CAN B149.1 for Canada.

CHECK GAS SUPPLY INLET PRESSURE

CSA or UL listed flexible gas connections are acceptable, but make sure that the line has adequate capacity to allow your water heater to fire at full rate. Consult with local codes for proper installation or service procedures.

Do not adjust or attempt to measure gas valve outlet pressure. Attempting to alter or measure the gas valve outlet pressure could result in damage to the valve, causing potential severe personal injury, death, or substantial property damage.

Make sure the gas piping are sized for the proper flow and length of pipe, to avoid excessive pressure drop. The gas meter and the gas regulator must be properly sized for the total gas load.

Perform the below steps when checking inlet gas supply:

1. Turn the main power switch to the "OFF" position.
2. Shut off gas supply.
3. Remove the 1/8" pipe plug on the main gas shutoff valve and install a suitable 1/8" fitting (field supplied) for the manometer tubing. Place the tubing of the manometer over the tap once the 1/8" fitting is installed.
4. Slowly turn on the gas supply.
5. Ensure inlet pressure is within specified range.
6. If the gas pressure is out of range, contact the gas utility, gas supplier, qualified installer or service agency to determine the necessary steps to provide proper gas pressure to the control.

CHECK FOR GAS LEAKS

Before operating the water heater, make sure to check the floor near and around the water heater for gas odorant or any unusual odor. Remove the top access panel and check for odor in the interior of the water heater enclosure. Do not start the water heater if there is any indication of a gas leak. Use an approved leak detection solution and repair any leaks at once.

In the case of propane water heaters, the supplier mixes an odorant with the propane to make its presence detectable. But in some instances, the odorant can fade, and the gas may no longer have an odor. Before operating the water heater, make sure the propane supplier verify the correct odorant level in the gas.

Do not adjust or attempt to measure gas valve outlet pressure. The gas valve is factory set for the correct outlet pressure. This setting is suitable for natural gas and propane, requiring no field adjustment. Attempting to alter or measure the gas valve outlet pressure could result in damage to the valve, causing potential severe personal injury, death, or substantial property damage.

START UP AND OPERATIONS

IMPORTANT

Only an A. O. Smith Certified Start-up agent must perform the initial firing of the water heater. At this time the user should not hesitate to ask the start-up agent any questions regarding the operation and maintenance of the unit. If you still have questions, please contact the factory or your local A. O. Smith representative. Contact Technical Support noted on the back cover for the name of your closest Certified Start-Up agent.

Lighting and Operating instructions are included with this manual. By using these instructions, the user may be able to make minor operational adjustments and save unnecessary service calls. However the user should not attempt repairs, but should contact a service technician or gas supplier.

GENERAL

Never operate the water heater without first making sure the water heater and system are filled with water, in addition:

- Make sure a temperature and pressure relief valve is installed in the storage tank for hot water supply installations.
- Make sure that the water heater and system have been purged of air and checked for leaks.

Also ensure to check the gas piping for leaks before beginning the initial firing of the water heater.

FILLING AND PURGING OF HEATING WATER HEATER INSTALLATION

1. Fast fill system through bypass until pressure approaches desired system pressure. Close bypass valve and permit pressure to be established by the pressure reducing valve.
2. Vent all high points in system to purge system of air.

Provisions should be made to permit manual venting of radiators or convectors.

FILLING HOT WATER SUPPLY WATER HEATER INSTALLATION

1. Close the system's drain valve by turning handle clockwise.
2. Open a nearby hot water faucet to permit the air to escape
3. Fully open the cold water inlet pipe valve allowing the water heater and piping to be filled.
4. Close the hot water faucet as water starts to flow.

PURGING GAS LINE

Gas line purging is required with new piping or systems in which air has entered.

INLET GAS PRESSURE

The inlet gas pressure is measured by removing the 1/8" NPT Plug located on the upstream side of the supply gas valve, and insert a 1/8" NPT hose barb fitting to be connected to a manometer or pressure gauge. Once pressure has been checked and/or adjusted, replace the plug and check for leaks. The maximum value specified in Table 2 on Page 6 must not be exceeded. The minimum values, shown in Table 2, must be maintained under both load and no load conditions (static and firing conditions). The combination gas valves supplied with the water heater are for low pressure service. If upstream pressure exceeds 14.0" W.C., an intermediate gas pressure regulator of the lockup type must be installed.

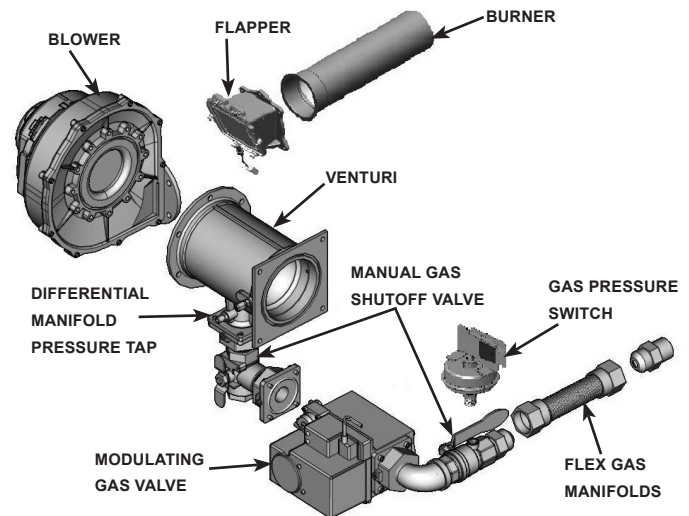

FIGURE 40. GAS TRAIN ASSEMBLY

MANIFOLD PRESSURE CONNECTIONS

Check the manifold pressure (refer to Table 2 on Page 6) by removing the pipe plug (located on the back of the water heater near the main gas shutoff valve, see Figure 39) and inserting a suitable 1/8" NPT hose barb for connection to the manometer/pressure gauge. Upon completion of measurements and adjustments, remove the hose barb and replace the pipe plug. Check for gas leaks and insure all connections are gas tight, see Figure 40.

CAUTION
Gas Supply
Should overheating occur or the gas supply fail to shut off, turn off the gas supply at a location external to the water heater (i.e., main manual gas shutoff valve).
Light the water heater in accordance with the instructions provided on the label affixed to the water heater's front door on the inside.

WATER TEMPERATURE REGULATION

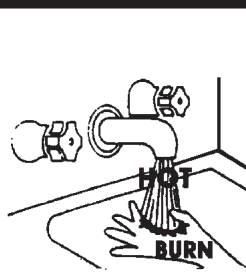
DANGER	Untempered hot water can cause severe burns instantly resulting in severe injury or death.
	Children, elderly, and the physically or mentally disabled are at highest risk for scald injury.
	Feel water before bathing or showering. Temperature limiting valves are available.
	Read instruction manual for safe temperature setting.

HOT WATER CAN SCALD: Water heaters are intended to produce hot water. Water heated to a temperature which will satisfy space heating, clothes washing, dish washing and other sanitizing needs can scald and permanently injure you upon contact. Some people are more likely to be permanently injured by hot water than others. These include the elderly, children, the infirm or physically/mentally disabled. If anyone using hot water in your home fits into one of these groups or if there is a local code or state law requiring a specific temperature water at the hot water tap, then you must take special precautions. In addition to using the lowest possible temperature setting that satisfies your hot water needs, a means such as a mixing valve should be used at the hot water taps used by these people or at the hot water supply tank. Mixing valves are available at plumbing supply or hardware stores. Follow the manufacturer's instructions for installation of the valves. Before changing the thermostat setting on the hot water system controller, refer to Table 17.

Hot water temperatures required for automatic dishwasher and laundry use can cause scald burns resulting in serious personal injury and/or death. The temperature at which injury occurs varies with the person's age and time of exposure. The slower response time of children, aged or disabled persons increases the hazards to them. Never allow small children to use a hot water tap, or to draw their own bath water. Never leave a child or disabled person unattended in a bathtub or shower.

The water heater should be located in an area that is inaccessible to the general public.

TABLE 17. RISK OF SCALDS

Water Temperature °F	Time for 1st Degree Burns (Less Severe Burns)	Time for Permanent Burns 2nd & 3rd Degree Burns (Most Severe Burns)
110	(normal shower temp.)	
116	(pain threshold)	
116	35 minutes	45 minutes
122	1 minute	5 minutes
131	5 seconds	25 seconds
140	2 seconds	5 seconds
149	1 second	2 seconds
154	instantaneous	1 second

(U.S. Government Memorandum, C.P.S.C., Peter L. Armstrong, Sept. 15, 1978)

Should overheating occur or the gas supply fail to shut off, turn off the main manual gas shutoff valve to the water heater.

CHECK/CONTROL WATER HARDNESS

XWH water heaters are approved for use in Domestic Water Heating Systems with a water supply hardness of 0 grains per gallon to a maximum of 12 grains per gallon and a Total Dissolved Solids (TDS) not exceeding 350 PPM. Heating water having higher grains/TDS specified here requires larger circulating pump. Consult manufacturer when heating water exceeding these specs. Refer to Table 18 for recommend flow rate to maintain scale free operation with up to a medium water hardness. For scale free operation in hard water systems with a water hardness greater than 12 grains per gallon, a water softener must be installed and maintained.

TABLE 18. WATER HARDNESS MEDIUM (0-12 GRAINS PER GALLON)

MODEL NO. (XWH)	ΔT °F	GPM (LPM)	ΔP FEET
1000	25	76 (287.6)	17.5
1300	25	99 (374.7)	22
1700	25	129 (488.2)	23
2000	25	152 (575.3)	17.5
2600	25	198 (749.4)	22
3400	25	258 (976.53)	23

ΔT °F = Temperature rise °F at the specified GPM.

GPM = Flow rate in gallons per minute.

ΔP = Pressure loss through the heat exchanger in feet of head.

For systems over 5 grains per gallon; and for scale free operation, water heater setpoint should not exceed 140 °F.

NOTE: The factory installed/supplied pump on the above listed model water heaters is sized to maintain a 25 °F ΔT through the water heater when the water heater is firing at 100% fire.

In addition to the pressure loss through the heat exchanger, the factory supplied pump is sized for an additional 50 feet (15.2 m) of equivalent feet of piping between the water heater and a storage tank. All piping between the water heater and the storage tank must be of a pipe size equal to the inlet/outlets of the water heater. Installation differences may slightly change these parameters.

FREEZE PROTECTION

1. Determine freeze protection fluid quantity using system water content, following fluid manufacturer's instructions.
2. Local codes may require a backflow preventer or actual disconnect from city water supply.
3. When using freeze protection fluid with automatic fill, install a water meter to monitor water makeup. Freeze protection fluid may leak before the water begins to leak, causing concentration to drop, reducing the freeze protection level.

INSPECT/FILL CONDENSATE SYSTEM

Inspect/check condensate lines and fittings:

1. Inspect the condensate drain line, condensate PVC fittings and condensate trap. Repair any leaks.

Fill condensate trap with water:

1. Remove the 2 inch PVC cap with the switch located at the top of the trap.
2. Fill with fresh water until the water begins to pour out of the drain.
3. Replace the cap. Press the cap onto the trap until the cap makes contact with the drain.

The condensate trap must be filled with water during all times of water heater operation to avoid flue gas emission from the condensate drain line. Failure to fill the trap could result in severe personal injury or death.

LIGHTING AND OPERATING INSTRUCTIONS

FOR YOUR SAFETY READ BEFORE OPERATING



WARNING: IF YOU DO NOT FOLLOW THESE INSTRUCTIONS EXACTLY, A FIRE OR EXPLOSION MAY RESULT CAUSING PROPERTY DAMAGE, PERSONAL INJURY OR LOSS OF LIFE.



- A. THIS APPLIANCE DOES NOT HAVE A PILOT. IT IS EQUIPPED WITH AN IGNITION DEVICE WHICH AUTOMATICALLY LIGHTS THE BURNER. DO NOT TRY TO LIGHT THE BURNER BY HAND.
- B. BEFORE LIGHTING: SMELL ALL AROUND THE APPLIANCE AREA FOR GAS. BE SURE TO SMELL NEXT TO THE FLOOR BECAUSE SOME GAS IS HEAVIER THAN AIR AND WILL SETTLE ON THE FLOOR.
- WHAT TO DO IF YOU SMELL GAS
- DO NOT TRY TO LIGHT ANY APPLIANCE.
 - DO NOT TOUCH ANY ELECTRIC SWITCH;
 - DO NOT USE ANY PHONE IN YOUR BUILDING.
 - IMMEDIATELY CALL YOUR GAS SUPPLIER FROM A NEIGHBOR'S PHONE. FOLLOW THE GAS SUPPLIER'S INSTRUCTIONS.
 - IF YOU CAN NOT REACH YOUR GAS SUPPLIER, CALL THE FIRE DEPARTMENT.
- C. USE ONLY YOUR HAND TO TURN THE MAIN MANUAL GAS VALVE. NEVER USE TOOLS. IF THE KNOB WILL NOT PUSH IN OR TURN BY HAND, DON'T TRY TO REPAIR IT. CALL A QUALIFIED SERVICE TECHNICIAN. FORCE OR ATTEMPTED REPAIR MAY RESULT IN A FIRE OR EXPLOSION.
- D. DO NOT USE THIS APPLIANCE IF ANY PART HAS BEEN UNDER WATER. IMMEDIATELY CALL A QUALIFIED SERVICE TECHNICIAN TO INSPECT THE APPLIANCE AND TO REPLACE ANY PART OF THE CONTROL SYSTEM AND ANY GAS CONTROL WHICH HAS BEEN UNDER WATER.
- E. DO NOT OPERATE APPLIANCE UNLESS UNIT IS FILLED WITH WATER AND WATER LINES ARE FULLY OPEN.

GAS FLOW

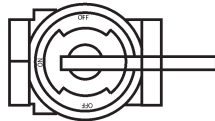

OPEN

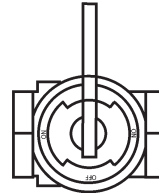

CLOSED

OPERATING INSTRUCTIONS

1. STOP! READ THE SAFETY INFORMATION ABOVE ON THIS LABEL.
2. SET SYSTEM TEMPERATURE CONTROLLER TO LOWEST SETTING.
3. TURN OFF ELECTRIC POWER TO THE BOILER.
4. CLOSE MAIN VALVE. TURN MAIN MANUAL GAS VALVE TO "OFF" OR CLOSED POSITION. THE VALVE IS "OFF" WHEN THE HANDLE IS PERPENDICULAR TO THE GAS FLOW DIRECTION.
5. WAIT FIVE (5) MINUTES TO CLEAR OUT ANY GAS. THEN SMELL FOR GAS INCLUDING NEAR THE FLOOR. IF YOU SMELL GAS STOP! FOLLOW "B" IN THE SAFETY INFORMATION ABOVE ON THIS LABEL. IF YOU DO NOT SMELL GAS, GO TO THE NEXT STEP.
6. OPEN MAIN VALVE. TURN MAIN GAS VALVE TO "ON" OR OPEN POSITION. THE VALVE IS IN THE "ON" POSITION WHEN THE HANDLE IS PARALLEL TO THE GAS FLOW DIRECTION.
7. THIS APPLIANCE IS EQUIPPED WITH AN IGNITION DEVICE WHICH AUTOMATICALLY LIGHTS THE BURNER. DO NOT TRY TO LIGHT THE BURNER BY HAND.
8. TURN ON POWER TO THE APPLIANCE.
9. SET SYSTEM TEMPERATURE CONTROLLER TO DESIRED OPERATING TEMPERATURE.
10. IF THE APPLIANCE WILL NOT OPERATE, FOLLOW THE INSTRUCTIONS TO TURN OFF GAS TO APPLIANCE. CALL YOUR SERVICE TECHNICIAN OR GAS SUPPLIER.

TO TURN OFF GAS TO APPLIANCE

- A. SET SYSTEM TEMPERATURE CONTROLLER TO LOWEST SETTING.
- B. TURN OFF ELECTRICAL POWER TO BOILER.
- C. CLOSE MAIN VALVE. TURN MAIN MANUAL GAS VALVE TO "OFF" OR CLOSED POSITION. THE VALVE IS IN THE "OFF" POSITION WHEN THE HANDLE IS PERPENDICULAR TO THE GAS FLOW DIRECTION.

ADJUSTMENT

! WARNING

Breathing Hazard - Carbon Monoxide Gas



Failure to make accurate adjustments could cause improper combustion resulting in death.

Breathing carbon monoxide can cause brain damage or death.
Always read and understand instruction manual.

There must be sufficient load to operate the water heater at high fire to perform the following adjustments. Start the water heater and observe proper operating parameters for the system.

Required Tools:

- TORX® T40 or 5 mm hex wrench
- 3 mm or 7/64 inch hex wrench
- Combustion analyzer

These water heaters are equipped with a combined gas/air control and gas safety shut off control valves. The valve functions in parallel with the variable speed combustion blower to supply the correct gas air ratio for optimum performance and efficiency. The combustion blower speed is controlled automatically and determines the amount of negative pressure experienced by the gas safety shut off/control valves. The gas/air regulator adjusts gas flow to maintain the proper pressure at the outlet nozzle of the associated valve.

SETTING OF THE TEST MODE

On the Burner Home screen, select any individual water heater which will guide to Burner Information screen.

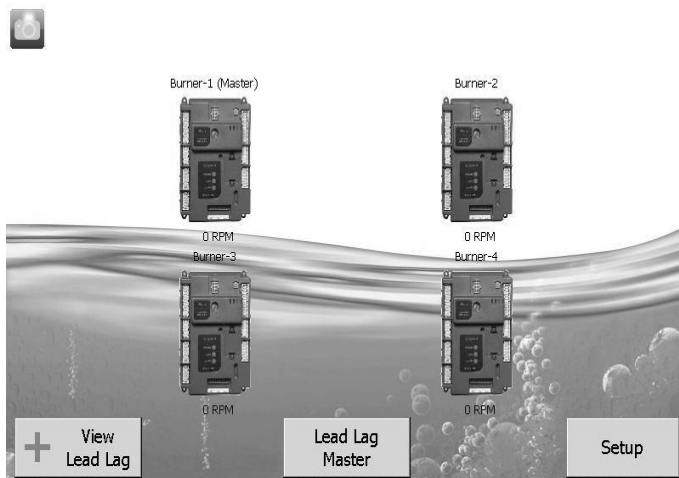

FIGURE 41. BURNER HOME SCREEN

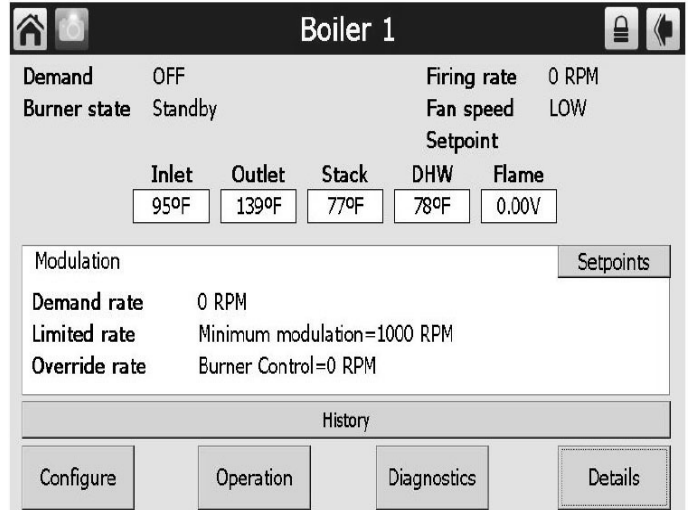

FIGURE 42. BURNER INFORMATION SCREEN

Click on Operation button, and under the Modulation Menu, set the required Firing rate (High/Low) by setting the RPM.

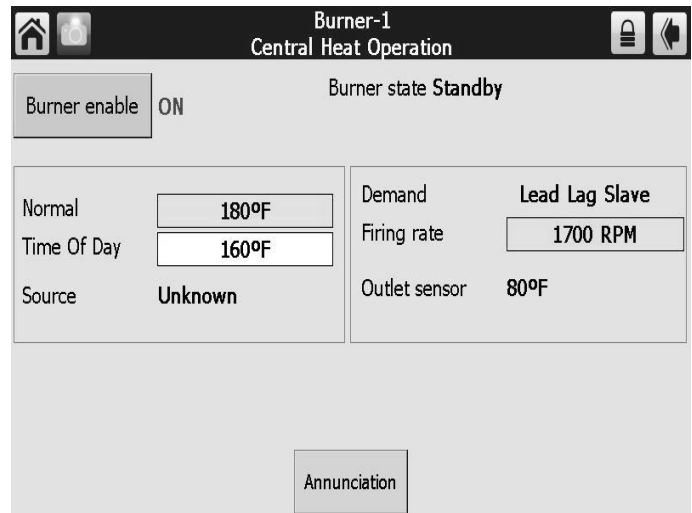

FIGURE 43. OPERATION SCREEN

On the Firing Rate page, set the Firing rate RPM by selecting the Manual in Run check box.

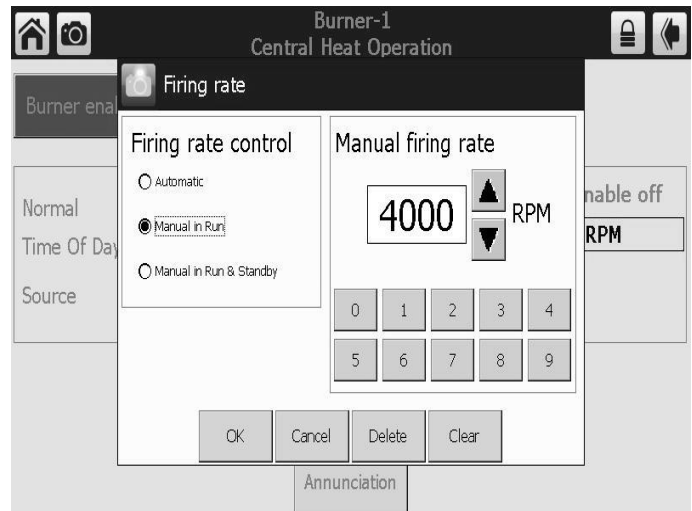

FIGURE 44. FIRING RATE PAGE

HIGH FIRING RATE SETTING

Set the water heater to the high firing rate by setting the High Firing Rate RPM as described below. Check combustion readings using a combustion analyzer. If combustion readings are not in accordance with the chart below adjust the gas valve as follows: remove the flat, round, blue plastic cap from the cover (see Figure 8 on Page 13). Using a 3 mm (7/64") hex wrench, turn the adjustment screw counterclockwise to increase or clockwise to decrease gas flow and achieve the desired CO₂ level. Make sure to close the water heater door after adjusting the gas valve for direct vent configurations. Refer to the Table 19 for correct settings. There will be a slight time delay between the adjustment and the response of the CO₂ measuring instrument. Adjust the settings in small increments and allow the combustion readings to stabilize before readjusting. When desired adjustments are complete, reinstall the blue plastic cap on the cover. Combustion samples should be taken in the stack within two feet of the water heater. The carbon monoxide (CO) values in the combustion sample should not exceed 150 PPM under any circumstances. Contact OEM for any abnormal conditions leading to excessive CO above 150 PPM.

TABLE 19. HIGH FIRE RATE

MODELS (XWH)	RPM (APPROXIMATE FACTORY SET)		CO ₂		*MANIFOLD PRESSURE INCHES W.C (KPA)	
	NATURAL GAS	PROPANE	NATURAL GAS	PROPANE	NATURAL GAS	PROPANE
1000	4450	4750	8.5 - 9.2%	9.3 - 10.2%	-3.5 (-0.87)	-4.7 (-1.17)
1300	4850	5100	8.5 - 9.2%	9.3 - 10.2%	-3.0 (-0.75)	-3.6 (-0.89)
1700	5700	5700	8.5 - 9.2%	9.3 - 10.2%	-3.6 (-0.89)	-4.4 (-1.09)
2000	4700	4750	8.5 - 9.2%	9.3 - 10.2%	-3.9 (0.97)	-4.9 (-1.22)
2600	5200	5100	8.5 - 9.2%	9.3 - 10.2%	-3.3 (-0.82)	-3.6 (-0.89)
3400	5700	5700	8.5 - 9.2%	9.3 - 10.2%	-3.5 (-0.87)	-4.4 (-1.09)

LOW FIRING RATE SETTING

Set the water heater to the low firing rate by setting the Low Firing Rate RPM as described below. Check combustion readings using a combustion analyzer. If combustion readings are not in accordance with the chart shown below adjust as follows: remove the cap on the gas regulator using a slotted screwdriver (see Figure 8 on Page 13). This will expose the offset adjustment screw. Using a TORX® T40 or a 5 mm hex wrench, carefully adjust the low fire gas setting to achieve the CO₂ level prescribed in Table 20.

Adjustments to the offset pressure regulators should not exceed 1/4 turn at a time before allowing the readings to respond and stabilize.

After proper low fire offset adjustment is made, reinstall the slotted cap on the regulator.

Following all gas valve adjustments, check for proper light-off and verify correct fuel/air mix and combustion quality throughout the entire firing range (from lowest to highest fan speed).

NOTE: The rotation of the Low Fire adjustment is opposite of the High Fire as follows: Clockwise rotation increases gas flow, counterclockwise rotation decreases gas flow. Make sure the Manual Mode is set back to Automatic Mode to each of the burners, once the required settings are done. Turn off the individual burner before proceeding to the next burner settings. Depending on the water heater size and capacity, the flame voltage will be between 10-15 volts for low fire and 25-32 volts for high fire settings. Check for gas valve settings and combustion for varied voltage levels.

TABLE 20. LOW FIRE RATE

MODELS (XWH)	RPM (APPROXIMATE FACTORY SET)		CO ₂		*MANIFOLD PRESSURE INCHES W.C (KPA)	
	NATURAL GAS	PROPANE	NATURAL GAS	PROPANE	NATURAL GAS	PROPANE
1000	1650	1540	7.3 - 8.2%	8.4 - 8.8%	-0.3 (-0.07)	-0.25 (-0.06)
1300	1650	1600	7.3 - 8.2%	8.4 - 8.8%	-0.2 (-0.05)	-0.14 (-0.03)
1700	1700	1700	7.3 - 8.2%	8.4 - 8.8%	-0.2 (-0.05)	-0.23 (-0.05)
2000	1550	1540	7.3 - 8.2%	8.4 - 8.8%	-0.3 (-0.07)	-0.31 (-0.07)
2600	1700	1600	7.3 - 8.2%	8.4 - 8.8%	-0.2 (-0.05)	-0.14 (-0.03)
3400	1700	1700	7.3 - 8.2%	8.4 - 8.8%	-0.2 (-0.05)	-0.23 (-0.05)

* NOTE: Values listed in Table 19 and Table 20 are tested under laboratory conditions with minimum vent length. Values may slightly vary depending on ambient conditions and field equipment accuracy.

CONTROL SYSTEM

BURNER CONTROL SYSTEM

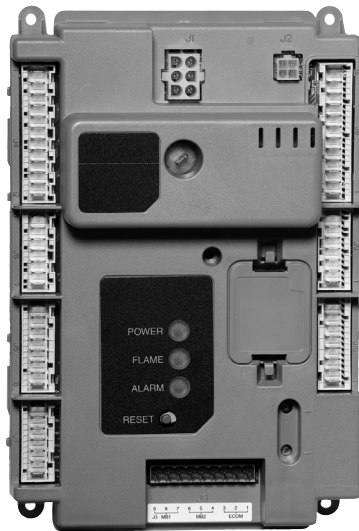

FIGURE 45. R7910A1138 CONTROL SYSTEM

The R7910A1138 is a burner control system that provide heat control, flame supervision, circulation pump control, fan control, water heater control sequencing, and electric ignition function. It will also provide water heater status and error reporting. Multiple water heaters can be joined together to heat a system instead of a single, larger burner or water heater. Using water heaters in parallel is more efficient, costs less, reduces emissions, improves load control, and is more flexible than the traditional large water heater. Control System consists of:

- R7910A1138 Control Device.
- S7999D Touchscreen Display—required for setup and ModBus communication but not required for the system to operate once the R7910A1138 is programmed.
- S7910A Local Keyboard Display Module.
- Flame Sensor.
- Temperature Sensor, NTC Type 10KΩ at 77°F (25°C) or 12KΩ at 77°F (25°C).
- Limit Sensor, NTC Type 10KΩ at 77°F (25°C).
- 24V Digital I/O.

OVERVIEW

Functions provided by the R7910A1138 include automatic water heater sequencing, flame supervision, system status indication, firing rate control, load control, CH/DHW control, limit control, system or self-diagnostics and troubleshooting.

The R7910 maximum version of the controller offers:

1. NTC-temperature sensor for:
 - Outlet Limit And Temperature.
 - Stack Temperature Limit and Temperature.
 - Inlet Temperature.
 - Outdoor Temperature (R7910 only).
2. Modulating output PWM-driven rotation speed controlled DC-fan for optimal modulation control.

3. Three Pump Outputs with 5 selectable operation modes.
4. 24VAC:
 - Output control of gas valve (Pilot and Main) and External Ignition Transformer.
 - Digital inputs for room limit control, high limit control, Gas pressure switch, low water cutoff.
5. External spark transformer.
6. Flame Sensor.
7. Test jacks for flame signal measurement from either a flame rod or UV flame sensor.
8. Alarm Output.

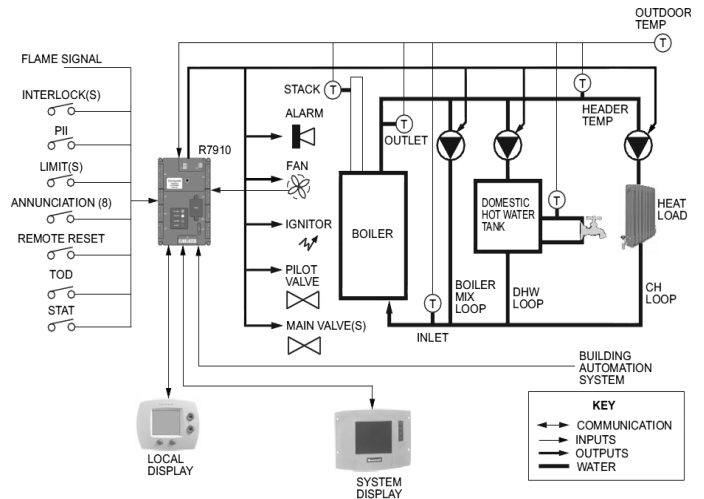

FIGURE 46. GENERAL R7910A1138 SCHEMATIC

The above figure shows two loops of heat control: Central Heating (CH), and an optional second loop for Domestic Hot Water (DHW) can be configured on each R7910A. The XWH water heaters are factory configured for DHW applications.

COMMUNICATIONS AND DISPLAYS

Two modes of communications are available to the R7910.

1. The R7910 has two RS485 communication ports for ModBus that allows for interfacing to one or all R7910s of a system and presents them individually to the user. The S7999D System Operator interface is a color touchscreen displays used for configuration and monitoring of the R7910A. Control Operation and display status in both test and graphical modes can be shown along with the ability to setup. The R7910 can also be remotely reset through the S7999D display.
2. Either ModBus RS485 communication port can be used to allow configuration and status data to be read and written to the R7910. Support a Master S7999D or a Building Automation master to control the R7910 to respond to a single ModBus address to service the requests of the ModBus master in a Lead/Lag arrangement.

The local S7910 Keyboard display, the S7999D System Operator interface, and the S7999C Local Operator Interface are optional components.

The S7999D (or the DSP3944 which is a portable S7999D) or is required configuration of the parameters of the R7910 but is not needed for the operation of the system once configured.

SPECIFICATIONS

1. Electrical Ratings:

Operating voltage

- 24VAC (20 to 30 VAC, 60 Hz $\pm 5\%$)
- 30 amps (Single Heat Exchanger)
- 60 amps (Double Heat Exchanger)

Connected Load for Valve and annunciator functions:

- 24VAC, 60Hz
- 120VAC (+10%/-15%), 60Hz ($\pm 5\%$)
- Model Specific

2. Corrosion:

- R7910A must not be used in a corrosive environment.

3. Operating Temperature: -4°F to 150°F (-20°C to 66°C)

4. Storage/Shipping Temperature: -40°F to 150°F (-40°C to 66°C).

5. Humidity:

- Up to 95% Relative Humidity, noncondensing at 104°F for 14 days. Condensing moisture may cause safety shutdown.

6. Vibration: 0.0 to 0.5g Continuous (V2 level)

7. Enclosure: Nema 1/IP40.

8. Approvals:

Underwriters Laboratories, Inc. (UL): Component Recognized: File No. MP268 (MCCZ)

- R7910 is certified as UL372 Primary Safety Controls.
- The R7910 is certified as UL353 Limit Rated device when using part number 50001464 dual element limit rated NTC sensors.

CSD-1 Acceptable.

Meets CSD-1 section CF-300 requirements as a Primary Safety Control.

Meets CSD-1 section CW-400 requirements as a Temperature Operation control.

Meets CSD-1 section CW-400 requirements as a Temperature High Limit Control when configured for use with 10 kohm NTC sensors.

Federal Communications Commission, Part 15, Class B. Emissions.

BURNER CONTROL OPERATION

SAFETY SHUTDOWN OF BURNER CONTROL FUNCTIONS

Safety Shutdown (Lockout) occurs if any of the following occur during the indicated period:

1. INITIATE PERIOD:

- a. A/C line power errors occurred.
- b. Four minute INITIATE period has been exceeded.

2. STANDBY PERIOD:

- a. Flame signal is present after 240 seconds.
- b. Main Valve Terminal is energized.
- c. Internal system fault occurred.

3. PREPURGE PERIOD:

- a. Flame signal is detected for 10 seconds accumulated time during PREPURGE.
- b. Purge Rate Fan RPM or High Fire Switch fails to close within four minutes and fifteen seconds after the firing rate motor is commanded to drive to the high fire position at the start of PREPURGE.
- c. Light off Rate Fan RPM or Low Fire Switch fails to close within four minutes and fifteen seconds after the firing rate motor is commanded to drive to the low fire position at the end of PREPURGE.
- d. Lockout Interlock (if programmed) does not close within 10 seconds.
- e. Lockout Interlock opens during PREPURGE.
- f. Main Valve terminal is energized.
- g. Internal system fault occurred.

4. PRE-IGNITION TIME

- a. Lockout Interlock opens.
- b. IAS Purge and Ignition enabled and the Interlock opens.
- c. Preignition Interlock opens.
- d. Pilot Valve terminal is energized.
- e. Main Valve terminal is energized.

5. PILOT FLAME ESTABLISHING PERIOD (PFEP):

- a. Lockout Interlock opens (if enabled).
- b. Pilot Valve terminal is not energized.
- c. No flame is present at the end of the PFEP, or after programmed number of retry attempts.
- d. Main valve terminal is energized.
- e. Internal system fault occurred.

6. MAIN FLAME ESTABLISHING PERIOD (MFEP):

- a. Lockout Interlock opens (if enabled).
- b. Pilot valve terminal is not energized.
- c. Main valve terminal is not energized.
- d. No flame present at the end of MFEP.
- e. Internal system fault occurred.

7. RUN PERIOD:

- a. No flame is present, or flame is lost (if enabled-lockout).
- b. Lockout Interlock opens) if enabled).
- c. IAS Purge and Ignition enabled and the Interlock opens.
- d. Pilot terminal energized (if programmed as Interrupted Pilot).
- e. Main valve terminal is not energized.
- f. Internal system fault occurred.

8. POSTPURGE PERIOD:

- a. Preignition Interlock does not close in five seconds.
- b. Pilot Valve terminal is energized.
- c. Main Valve terminal is energized.
- d. Internal system fault occurred.
- e. Flame sensed 240 seconds accumulated time after the RUN period.

SAFETY SHUTDOWN:

1. If the lockout interlocks open or a sensor designated as a safety limit are read as defective, Control System will lockout and the blower motor will be de-energized.

If these open during the firing period, all fuel valves will be de-energized, the system will complete postpurge, and will lockout indicated by an alarm.

2. If the main flame is not detected at the end of the last recycle attempt of the main flame establishing period, all fuel valves will be de-energized, the device will complete postpurge, and will lockout indicated by an alarm.
3. If the flame sensing signal is lost during the run period (if lockout is selected), all fuel valves will be de-energized within 4 seconds after the loss of the flame signal, the device will complete postpurge, and will lockout indicate by an alarm.
4. Manual reset is required following any safety shutdown. Manual reset may be accomplished by pressing the push button on the device, pressing the remote reset wired into connector J10, or through an attached display.

Interrupting power to Control System will cause electrical resets, but does not reset a lockout condition.

GENERAL OPERATIONAL SEQUENCE

INITIATE

The R7910 enters the Initiate sequence on Initial Power up or:

- Voltage fluctuations vary less than 20VAC or greater than 30VAC.
- Frequency fluctuations vary +/-5% (57 to 63 Hz).
- If Demand, LCI, or Stat interrupt (open) during the Prepurge Period.
- After the reset button is pressed or fault is cleared at the displays.

The Initiate sequence also delays the burner motor from being energized and de-energized from an intermittent AC line input or control input.

If an AC problem exists for more than 240 seconds a lockout will occur.

START-UP SEQUENCE

Start-up sequence DHW-request (system in standby):

1. Heat request detected (Tanks Sensor below Setpoint).
2. The pump is switched on.
3. After a system Safe Start Check, the Blower (fan) is switched on after a dynamic ILK switch test (if enabled).
4. After the ILK switch is closed and the purge rate proving fan RPM is achieved (or High Fire Switch is closed) - prepurge time is started.
5. When the purge time is complete, the purge fan RPM is changed to the Lightoff Rate or if used, the damper motor is driven to the Low Fire Position.
6. As soon as the fan-rpm is equal to the light-off rpm (or the Low Fire Switch closes), the Trial for Ignition or Pre-Ignition Time is started (depending on configuration).
7. Pre-Ignition Time will energize the ignitor and check for flame.
8. Trial for Ignition. Specifics for timings and device actions are defined by the OEM or installer.
9. The ignition and the gas valve are switched on.
10. The ignition is turned off at the end of the direct burner ignition period, or for a system that does use a pilot, at the end (or optionally at the middle) of the Pilot Flame Establishing Period (PFEP). For an interrupted pilot system this is followed by a Main Flame Establishing Period (MFEP) where the pilot ignites the main burner. For an intermittent pilot there is no MFEP.
11. The fan is kept at the lightoff rate during the stabilization timer, if any.
12. Before the release to modulation, the fan is switched to minimum RPM for the DHW Forced Rate and Slow Start Enable, if the water is colder than the threshold.
13. At the end of the DHW-heat request the burner is switched off and the fan stays on until post purge is complete.
14. The pump stays on during the pump overrun time.
15. At the end of the pump overrun time the pump will be switched off.

LEAD LAG

Burner Control System devices contain the ability to be a stand-alone control, operate as a Lead Lag Master control (which also uses the burner control function as one of the slaves), or to operate solely as a slave to the lead lag system.

Control System devices utilize two ModBus™ ports (MB1 and MB2) for communications. One port is designated to support a system S7999D display and the other port supports communications from the LL Master with its slaves.

The Lead Lag master is a software service that is hosted by a Control System. It is not a part of that control, but is an entity that is “above” all of the individual burner controls (including the one that hosts it). The Lead Lag master sees the controls as a set of Modbus devices, each having certain registers, and in this regard it is entirely a communications bus device, talking to the slave burner controls via Modbus.

The LL master uses a few of the host Burner Control's sensors (header temperature and outdoor temperature) and also the STAT electrical inputs in a configurable way, to provide control information.

LEAD LAG (LL) MASTER GENERAL OPERATION

The XWH is a multiple burner application and it works on the basis of the Lead Lag Operation. The XWH is factory configured for Domestic Hot Water application. The LL master coordinates the firing of its slave Control Systems. To do this it adds and drops stages to meet changes in load, and it sends firing rate commands to those that are firing.

The LL master turns the first stage on and eventually turns the last stage off using the same criteria as for any modulation control loop:

- When the operating point reaches the Setpoint minus the On hysteresis, then the first Control System is turned on.
- When the operating point reaches the Setpoint plus the Off hysteresis then the last slave Control System (or all slave Control Systems) are turned off.

The LL master PID operates using a percent rate: 0% is a request for no heat at all, and 100% means firing at the maximum modulation rate.

This firing rate is sent to the slaves as a percentage, but this is apportioned to the slave Control Systems according to the rate allocation algorithm selected by the Rate allocation method parameter.

For some algorithms, this rate might be common to all slave Control Systems that are firing. For others it might represent the total system capacity and be allocated proportionally.

For example, if there are 4 slaves and the LL master's percent rate is 30%, then it might satisfy this by firing all four slaves at 30%, or by operating the first slave at 80% (20% of the system's capacity) and a second slave at 40% (10% of the system's capacity).

The LL master may be aware of slave Control System's minimum firing rate and use this information for some of its algorithms, but when apportioning rate it may also assign rates that are less than this. In fact, the add-stage and drop-stage algorithms may assume this and be defined in terms of theoretical rates that are possibly lower than the actual minimum rate of the Burner Control System. A Control System that is firing and is being commanded to fire at less than its minimum modulation rate will operate at its minimum rate: this is a standard behavior for a Burner control system in stand-alone (non-slave) mode.

If any slave under LL Master control is in a Run-Limited condition, then for some algorithms the LL master can apportion to that stage the rate that it is actually firing at. Additionally when a slave imposes its own Run-limited rate, this may trigger the LL Master to add a stage, if it needs more capacity, or drop a stage if the run-limiting is providing too much heat (for example if a stage is running at a higher-than commanded rate due to anti-condensation).

By adjusting the parameters in an extreme way it is possible to define add-stage and drop-stage conditions that overlap or even cross over each other. Certainly it is incorrect to do this, and it would take a very deliberate and non-accidental act to accomplish it. But there are two points in this:

1. LL master does not prevent it, and more important;
2. It will not confuse the LL master because it is implemented as a state machine that is in only one state at a time;

For example:

— If its add-stage action has been triggered, it will remain in this condition until either a stage has been added,

Or

— The criteria for its being in an add-stage condition is no longer met; only then will it take another look around to see what state it should go to next.

DEFINITIONS

Modulating stage: The modulating stage is the Control System that is receiving varying firing rate requests to track the load.

First stage: This is the Control System that was turned on first, when no slave Control Systems were firing.

Previous stage: The Control System that was added to those stages that are firing Just prior to the adding of the Control System that is under discussion.

Next stage: The Control System that will or might be added as the next Control System to fire.

Last stage: The Control System that is firing and that was added the most recently to the group of slaves that are firing. Typically this is also the modulating stage, however as the load decreases then the last-added stage will be at its minimum rate and the previous stage will be modulating.

Lead water heater: The Lead water heater is the Control System that is the first stage to fire among those stages which are in the equalize runtime (Lead/Lag) group. If a water heater is in the “Use first” group it may fire before the Lead water heater fires.

First water heater: A Control System may be assigned to any of three groups: “Use First”, “Equalize Runtime”, or “Use Last”. If one or more Control Systems are in the “Use First” category, then one of these (the one with the lowest sequence number) will always be the first water heater to fire. If there is no Control System in the “Use First” category and one or more are in the “Equalize Runtime” category, then the First water heater is also the Lead water heater.

LOCAL OPERATOR INTERFACE: DISPLAY SYSTEM



FIGURE 47. BURNER CONTROL S7999D DISPLAY SYSTEM

The S7999D is a microprocessor-based color touch-screen Operator Interface (OI) display that provides an operator interface for monitoring and configuring parameters in the Burner Control system.

The S7999D can be used to monitor an individual water heater but is also used for multiple water heater applications in a lead/lag arrangement. It consists of 2 RS485 ports (COM 1 & COM 2) and USB port. The S7999D display can be flush front or behind mounted into a panel cutout. Wiring connections to the S7999D are through a removable 8-pin wiring connector.

FEATURES

- Individual water heater status, configuration, history, and diagnostics.
- Allows configuration and monitoring of the Burner Control Controls burner control sequence, flame signal, diagnostics, historical files, and faults.
- S7999D OI Display only:
 - Allows switching view between multiple burners.
 - Allows viewing Lead-Lag Master.
 - Real-time data trending analysis and transferring saved trend data to Excel spreadsheet.
 - 7" 800 x 480, 24 bit high resolution color LCD touch screen for clarity.
 - Audio output with integral speaker for sound output.
 - Adjustable backlight control.
 - Real time clock with coin-cell battery back up (CR2032).
 - S7999D has Black Border.
 - Volume control.
 - Screen Capture function to capture screen images.
 - USB port for file transfers and software updates
 - 2 RS-485 (COM1 & 2) ports for Modbus™ interface to Burner controls and BAS Gateway.
 - Windows® CE 6.0 Operating System.
 - 8-pin connector, back-up battery and mounting hardware are provided.

SPECIFICATIONS

1. Electrical Ratings:
 - Input Voltage: 18 – 30 Vac (24Vac nominal), 50/60 Hz

- Input Current: 500 mA max.
 - Power consumption: 12W max.
2. Operating Temperature: -4 to 158 °F (-20 to 70 °C)
 3. Storage/Shipping Temperature: -22 to 176 °F (-30 to 80 °C)
 4. Humidity: 90% RH, non-condensing.
 5. Enclosure rating: IP10 / NEMA 1
 6. Approvals:

FCC Part 15, Class A Digital Device

Underwriter's Laboratories, Inc. (UL) (cUL) Component Recognized (for non-continuous operation): File Number MH17367 (MJAT2, MJAT8).

INSTALLATION INSTRUCTIONS (S7999D OI DISPLAY)

The OI Display can be mounted on the door panel of an electrical enclosure.

1. Select the location on the door panel to mount the display; note that the device will extend into the enclosure at least one inch past the mounting surface.
2. Provide an opening in the panel door 8" wide X 5 1/2" high (for front panel mount) or 7 1/8" wide X 4 11/16" high (for rear panel mount).
3. Place the OI Display in the opening and use it as a template to mark the location of the four mounting screw holes. Remove the device.
4. Using pilot holes as guides, drill 1/4 in. holes through the door panel.
5. Place the display in the opening, aligning the mounting holes in the device with the drilled holes in the panel.
6. Secure the display to the panel with four #6-32 screws and nuts provided.
7. Wire the 24VAC power supply and the RS-485 cables.
8. Ensure the 8-pin connector plug is aligned with the header pins when inserting the 8-pin connector plug back onto the Display. Secure firmly.
9. Please make sure resistive spark cable is used with the display system, and route the wires away from the display as much as possible.

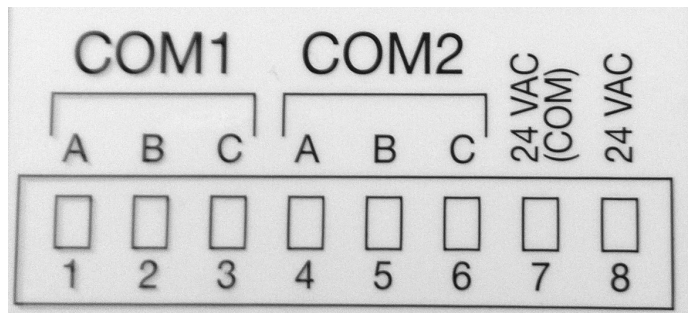

FIGURE 48. S7999D OI DISPLAY CONNECTOR TERMINALS

QUICK SETUP (S7999D OI DISPLAY)

1. Make sure the S7999D 8-pin connector is properly aligned and pressed firmly in place.
2. Make sure the wires between the 8-pin connector and the controller are properly wired and secure.

WARNING: Electrical Shock Hazard. Can cause severe injury, death or equipment damage. Line voltage is present at the 120 VAC power supply.

3. Make sure the power supply is connected securely to the 120 VAC power source.

STARTING UP THE S7999D OI DISPLAY

POWER-UP VALIDATION

The Home page will appear when the device is properly powered. Select the Setup button to adjust the contrast and sound as desired.

If the screen is dim, check the pin 7 and 8 wiring connections.

A “camera” icon on the left top corner is for screen snapshot use. Up to 16 snapshots can be stored in the display and can be copied to a USB memory stick.

NOTE: An Advanced Startup screen displays for five seconds after power-up before the Home page displays. This screen allows the user to upgrade the software in the System Display and should normally be bypassed.

Three LEDs exist for I/O traffic: one for the Ethernet network port and two for Modbus™ ports. Modbus Com Port 2 is not active on this device.

1. Make sure the Power and COM1 LEDs are blinking.
2. If the LEDs are not blinking:
 - Make sure the proper connections have been made between the Modbus COM1 Port and the first controller device in the Modbus network.
 - Ensure proper wiring of the OI Display 9-pin Header Connections.
3. If connected to a BAS application, COM2 LED will blink indicating BAS traffic.

HOME PAGE (S7999D OI DISPLAY)

Make sure a screen similar to Figure 49 appears after the OI Display has completely powered up.

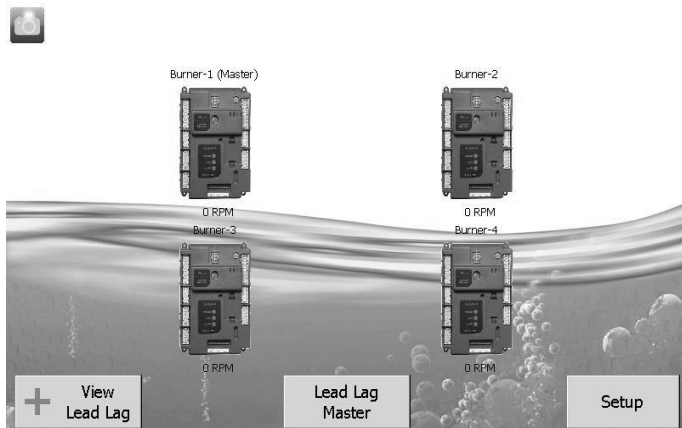

FIGURE 49. S7999D HOME PAGE (IN NORMAL OPERATION)

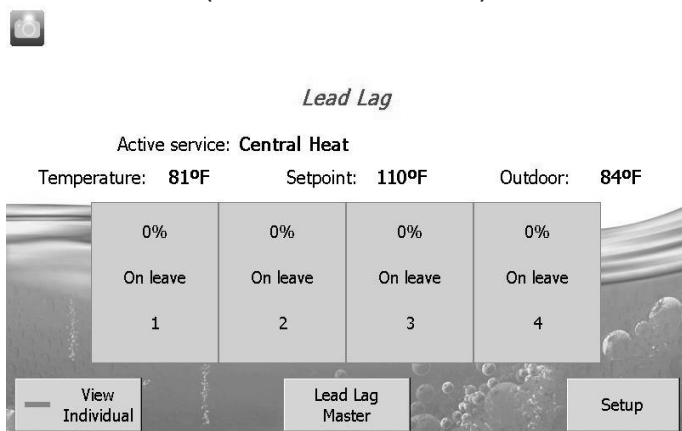

FIGURE 50. S7999D LEAD LAG HOME PAGE

On System applications, each Burner Control System is represented on the Home page by an icon and name. Pressing the icon allows the user to zoom in on that water heater and see its specific details. These details are provided on a new page, which can include additional buttons that display additional detail and operation information, which itself leads to other pages. The pages are traversed in a tree structure method, as shown in Figure 51 on Page 51.

The Control System icons will appear in one of four colors indicating the water heater status.

- Blue: Normal operation
- Red: Lockout condition
- Gray: Communication error (disconnected or powered off)
- Yellow: Holding mode.

Up to 8 Systems can be displayed on the Home page. The name of each water heater is displayed next to the Control System icon button. When Lead Lag is enabled, the system header temperature and firing rate are displayed for each System. When the burner is in standby or not firing the firing rate is not displayed.

NOTE: The water heater name may be cut off on the Home page when all icons are present.

The Home page also includes buttons for Lead Lag configuration when lead lag master and slave in the Burner control is enabled. Pressing the Setup button on the Home page displays miscellaneous setup and diagnostic functions. It also contains the setup configuration for BAS applications.

The “Control snapshot” button allows the user to dump the current status and/or configuration settings of any Burner controller into a text document. The text document can be viewed on the display, saved to flash for later viewing, and can be written to a USB stick for viewing on a PC or file transfer. Pressing the Burner control icon opens that control’s status page. Go to “Configure” button to continue.

PAGE NAVIGATION

The Burner Control System OI Displays present information and options in a paged manner. Pages are displayed in a tree structure in which the user navigates up and down to arrive at the desired Function (see Figure 51). The page descriptions are provided below so that you can understand the purpose of each and view the selections, parameters, and information that is available or required on each.

COMMON OI DISPLAY PAGE SYMBOLS

Most pages have a Home button in the top-left corner of the screen and a Back button in the top-right corner of the screen. The Home button returns the user to the Home page and terminates any operation in progress. The Back button returns the user to the previous page.

Two other icons may be noticed near the water heater name.

A camera button is for screen snapshot use. Up to 16 snapshots can be stored in the display and can be copied to a USB memory stick.

A padlock indicates the operator is not currently logged in (may have been timed out) and a password is needed to change the setting. An unlocked padlock indicates the password has been entered and the operator has logged into system successfully.

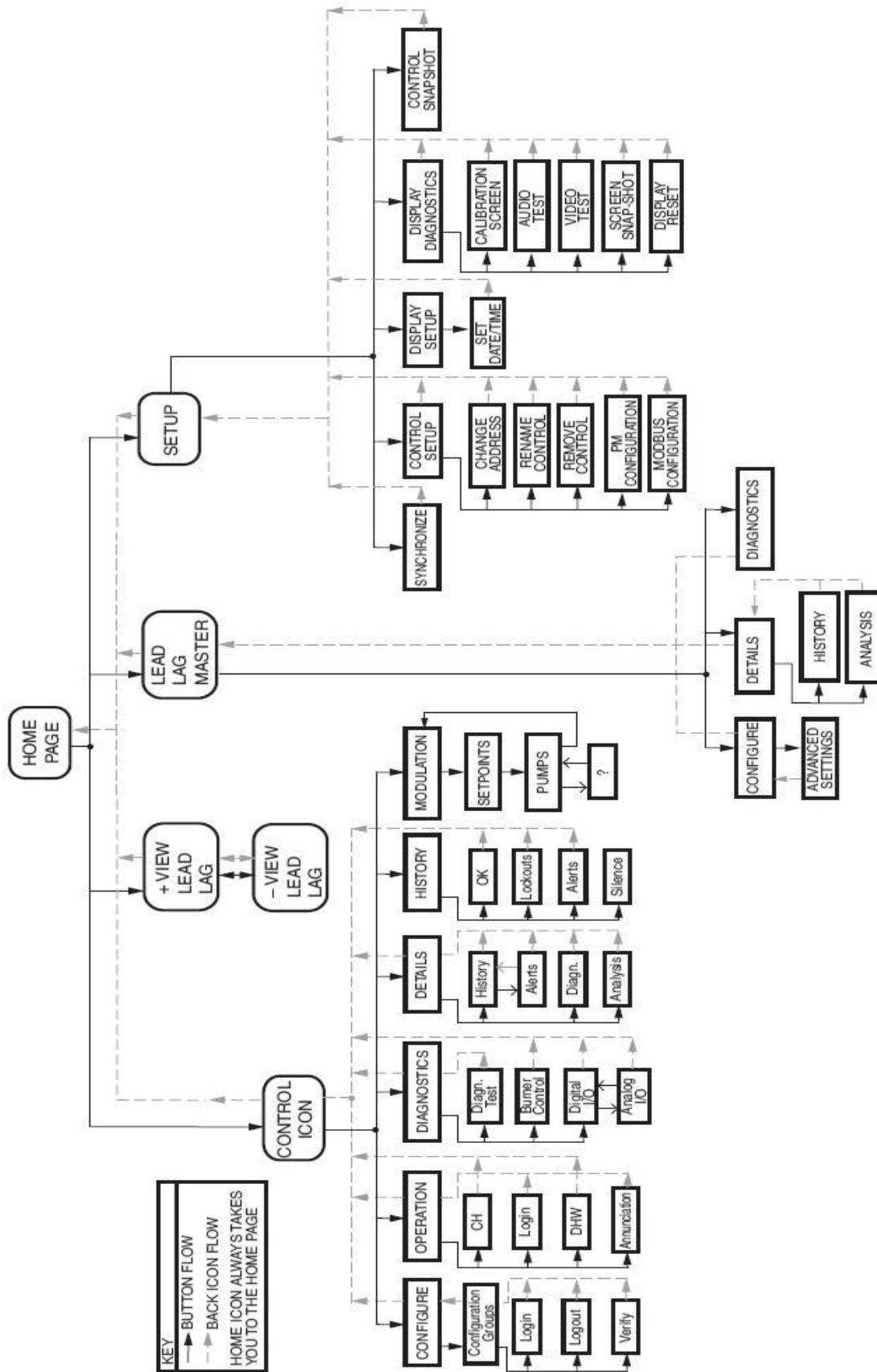

FIGURE 51. S7999D DISPLAY PAGE FLOW

STATUS OR HOME PAGE

A status (summary) page (Figure 52) is displayed when the S7999D display is connected. This status page appears on the S7999D when the Burner control icon is pressed on the “Home” page. The status page displays the current condition of the burner control and displays some of the more important configuration settings.

The water heater name associated with the burner control is displayed in the title on the status page.

NOTE: When the burner control has no water heater name defined, Modbus address is used to identify the water heater.

The initial status page displayed contains summary status information as shown in Figure 52. Any status information not applicable for the installation is grayed/blanked out on the screen.

Buttons on this screen include:

- **Configure:** used to configure the burner control (password protected).
- **Operation:** used to perform daily or frequent functions with the burner control, such as setpoint adjustment, etc.
- **Diagnostic:** used to view burner control diagnostic information.
- **Details:** used to view burner control detail status information.
- **History:** used to view burner control history
- **Pump:** used to expand the pump status information.
- **Modulation:** used to toggle between status displays: pump, setpoints, and modulation.

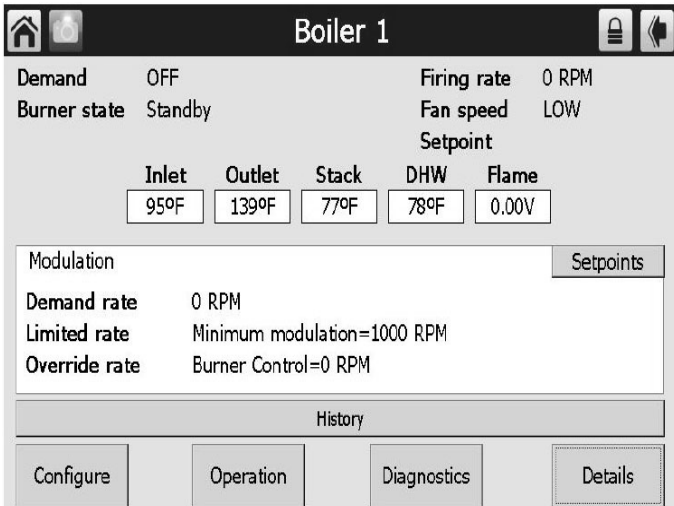

FIGURE 52. SUMMARY STATUS PAGE

CONFIGURE BUTTON

Pressing the Configure button (bottom left) on the Status page opens the Configuration page.

The S7999D Configuration page does not have a “Display Setup” button.

The configuration page allows the user to view and set parameters that define how the connected R7910A functions in the water heating system. All parameters are factory configured and only a Field Service Agent must perform the configuration settings.

The configuration page contains a menu of parameters grouped into functional areas that the user selects for configuration (see Figure 53).

No specific order for configuration is required. All parameters are enabled for editing, though some may not be applicable (e.g., a configuration parameter may disable a control feature). Selecting a parameter group from the menu displays parameters exclusively applicable for the functional group on the page (see Figure 54). These parameters can be edited, and when the user is finished, control returns back to the configuration menu page.

Each parameter is displayed in its group. If there are more parameters than will fit on the screen, a vertical scroll bar allows the user to scroll up and down to view all parameters. The parameter name is displayed on the left and the current setting is displayed in the text box on the right.

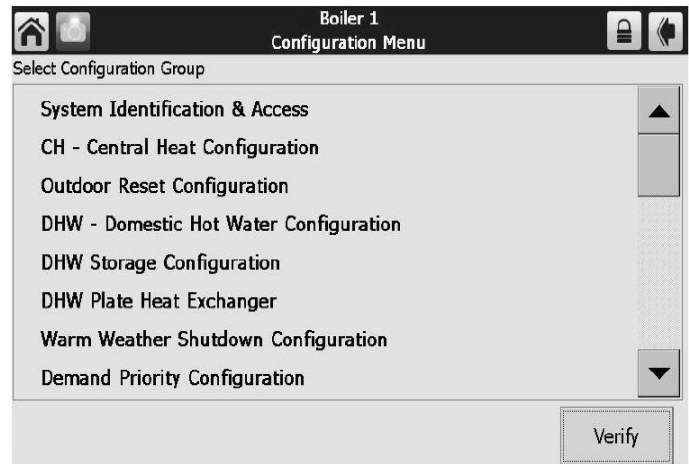

FIGURE 53. CONFIGURATION MENU PAGE

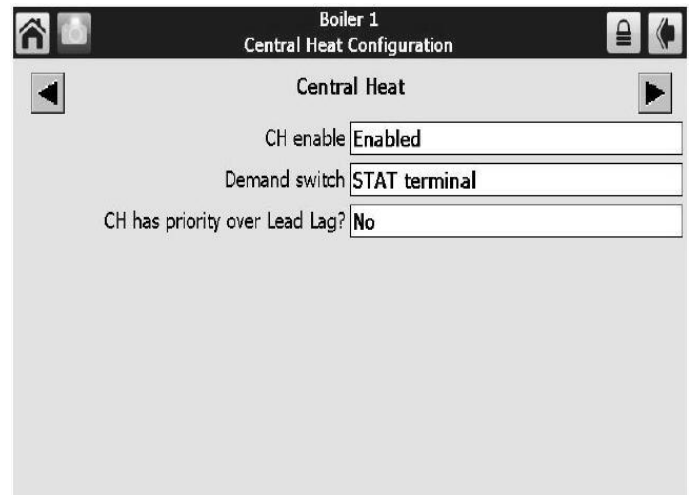

FIGURE 54. SAMPLE CONFIGURATION PAGE

CONFIGURATION PASSWORD

Some parameters require a valid configuration password be entered by the user before the parameter can be changed. The password need only be entered once while the user remains on the configuration pages and stays active. The display times out after 10 minutes of inactivity. User will have to login again if another secure parameter needs to be changed by pressing the Padlock button. Three levels of access to Burner Control parameters are permitted. Each access level has defined rights when interfacing with configuration and status parameters within the controls.

- **End user:** The end user can read or view the control parameters and be allowed to change some operating parameters, CH setpoint as an example. (The end user does not need password).
- **Installer:** The installer can read all control parameters and change default allowed parameters. This access level is used to customize the control for a particular installation.
- **OEM:** The OEM can read and change all parameters, change sensor limits and burner control safety parameters.

Different passwords exist in the Burner Control for each access level. The end user level requires no password, but the installer and OEM levels have unique passwords defined for them. The installer and OEM passwords can be changed in the Burner Control after logging in with the current password. When the password is changed, it is saved for all future logins.

NOTE: For the S7999D System OI display, each water heater in a multi-water heater configuration has its own set of installer and OEM passwords. To avoid user confusion, the passwords should be changed to the same password in each control, but there is no requirement to do so. Make sure to record your password.

The user is notified that a new password is needed to change a parameter (or until a password is entered successfully)—see Figure 54. The user can continue viewing the configuration parameters regardless of whether a password is entered successfully.

The Burner Controls maintain a password time-out that limits the scope of the password entry. Once a password is successfully entered, the control starts an internal timer that expires after 10 minutes of inactivity. After the timer expires, the user is required to re-enter a password before a parameter can be changed. The user is not required to enter a configuration password for a parameter that has a lower access level than the access level achieved by an earlier password entry for any configuration group (as long as the user stays in the configuration pages). The user only needs to enter a password once until a parameter that has a higher access level is selected.

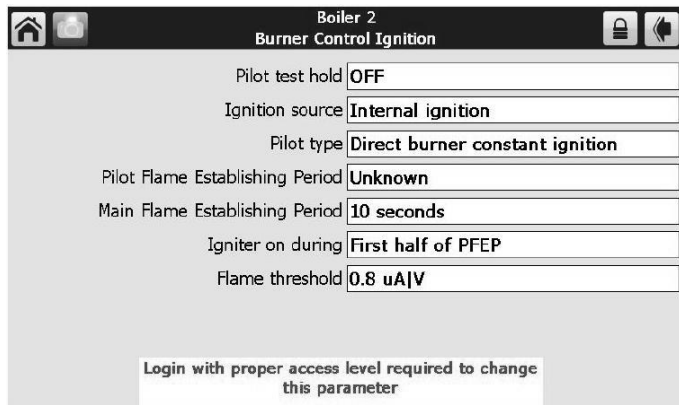

FIGURE 55. LOGIN REQUIRED

KEYBOARD

Some pages request user entry of characters. When this type of input is required, a keyboard page appears, as shown in Figure 56. The text box at the top of the screen displays the current (or default) setting of the user input. The user can add to this text, clear it, or change it.

The Shift key on the left side of the screen shifts between upper and lowercase characters. Pressing the Shift key toggles the keyboard from one mode to the other (continuous pressing of the Shift button is not required). The OK button should be pressed when the user is done entering the text input. The Cancel button on the bottom of the screen allows the user to ignore any text changes that have been made and keep the original text value. Pressing the OK or Cancel buttons returns the user to the page displayed prior to the keyboard page.

LOGIN

Pressing the Login button allows entering the password from a keyboard as shown in Figure 56. After the password is entered, the OK button is selected. The Cancel button aborts the password login.



FIGURE 56. DEVICE LOGIN SCREEN

WARNING: Explosion Hazard. Improper configuration can cause fuel buildup and explosion. Improper user operation may result in property loss, physical injury or death.

Using the OI Displays to change parameters must be attempted by only experienced and/or licensed burner/water heater operators and mechanics.

CHANGE PARAMETER SETTINGS

Change parameter settings by selecting the parameter on the page. A dialog box displays for the parameter with controls allowing the user to change the value (see Figure 57 on Page 54). After changing the setting to a new value, press the OK button. Pressing the Cancel button leaves the parameter unchanged. The changed setting is reflected on the screen and sent to the control when the OK button is pressed.

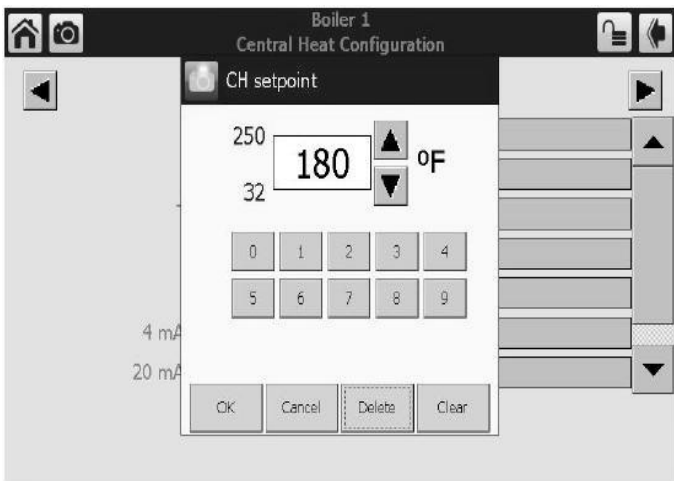

FIGURE 57. EXAMPLE OF CHANGE CONFIGURATION PARAMETER PAGE

VERIFY

Pressing the Verify button displays safety configuration parameters for an additional verification step to commit the changes.

Safety parameters are grouped into blocks that include only safety parameters, not a mixture of safety data and non-safety data. All parameters within the safety group undergo a verification process. A safety parameter group is identified on the display to indicate when the configuration parameters are safety-related. Each safety parameter group is verified one at a time until all have been verified. See Figure 58.

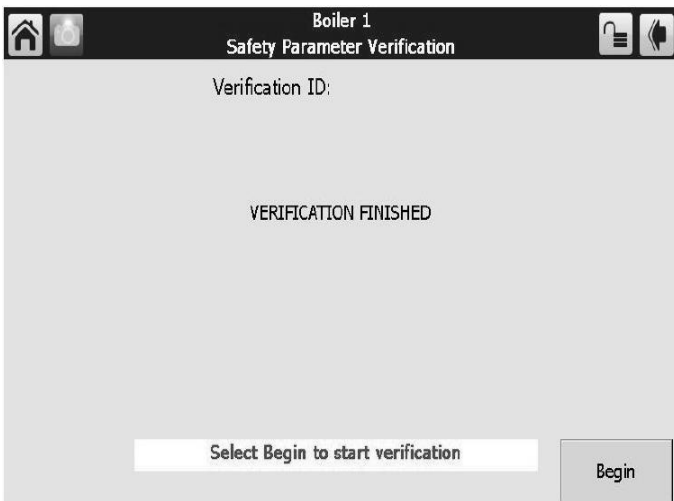

FIGURE 58. SAFETY VERIFICATION

Like operating parameters, safety parameters can be viewed without the need to enter a password.

Safety parameter blocks that have been changed require verification. The verification steps do not have to be completed immediately; the installer can move between and change parameter groups before the verification is done. A Verify button is enabled that allows the installer to conduct verification sessions (the example of the Verify button in Figure 53 is not yet enabled because the installer has not logged in).

NOTE: When the installer proceeds with the safety parameter configuration, the control unlocks the safety parameters in this group and marks them unusable. Failure to complete the entire safety configuration procedure leaves the control in an unrunnable state (lockout 2).

All safety configuration parameters in the group should have the same access level. If this condition isn't so, the user is asked to enter another password when a higher access level is needed.

Successful login is noted by the lock icon, which changes to "unlocked" on the page. The installer may begin to change safety parameters (or any other parameters) at that time (see Figure 59). If the Burner Control is in an unconfigured (or new) state, then this warning doesn't appear. All parameters that need changes should be changed during the login.

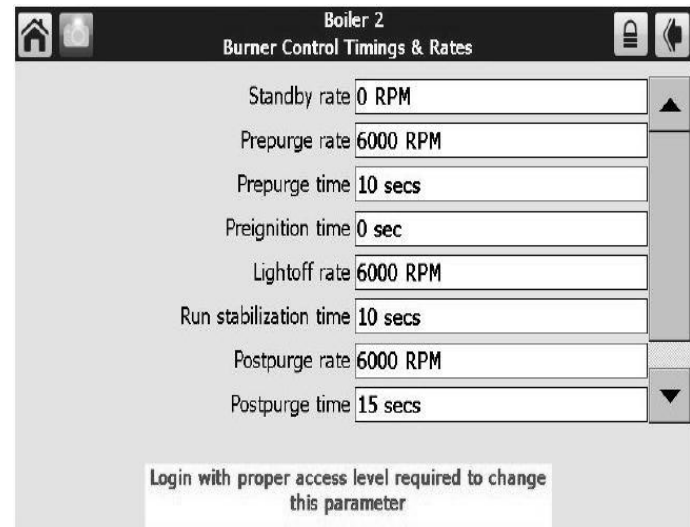

FIGURE 59. EDIT SAFETY DATA

If the safety configuration session is terminated after it has started (in the Edit or Verify stages), the Burner Control is left in an unconfigured (unrunnable) state.

The installer can terminate the session by pressing the Menu button or by attempting to leave the Verification page with the Home or Back buttons (top-left and -right screen corners, respectively). However, leaving the session at this point leaves the control in an unrunnable state and confirms whether the installer still wants to do so.

The settings of all parameters in each safety block must be verified to save them in the control.

When the installer is done changing safety parameters, pressing the Verify button on the configuration screen begins the Verification process. The settings for all safety parameters in each changed block are presented and Verified by the installer (see Figure 60 on Page 55).



FIGURE 60. SAFETY PARAMETER CONFIRMATION

Press the Yes button to confirm each safety parameter block. If the No button is selected, the safety parameter block remains unconfirmed and the Configuration menu page is displayed. The control remains in an unconfigured state in this case.

After all safety parameter blocks have been confirmed, the installer is asked to press and hold the Reset button on the Burner Control to complete the safety verification session (see Figure 61).



FIGURE 61. SAFETY PARAMETER RESET

When the Reset button is pressed and held for 3 seconds the confirmed safety parameters are saved in the control. The above Reset dialog box automatically closes when this step is completed.

If this step is not performed, the control remains in a safety lockout state until the installer resolves the unverified safety parameters.

FAULT/ALARM HANDLING

Each Burner Control reports to the OI display when a safety lockout or an Alert occurs.

Safety lockouts are indicated on each configuration page as an alarm bell symbol. At the status page (for S7999D), the History button turns red. If the S7999D is displaying the system status icons, the control in alarm will turn red.

The lockout history can be displayed by pressing on the History button. The state information about each lockout is displayed along with the date/time that the lockout occurred (refer to Table 21). Current date/time stamp is a display setup feature.

NOTE: In the event of a power interruption, the date/time must be reset. The OI Display does NOT have a backup means.

TABLE 21. BURNER CONTROL LOCKOUT HISTORY

DATA	COMMENT
Lockout time	Set by display
Fault Code	Unique code defining which lockout occurred.
Annunciator first out	First interlock in limit string results in a shutdown.
Description	Fault description
Burner Lockout/Hold	Source/reason for lockout/hold
Burner control state	
Sequence time	Burner control state timer at time of fault
Cycle	Burner control cycle
Run Hours	Burner control hours
I/O	All digital I/O status at time of fault
Annunciator 1-8 states	All annunciator I/O status at time of fault
Fault data	Fault dependent data

An alert log can be displayed for each control by pressing the Alert button on the bottom of the history status page. A description of the alert is displayed along with the time when the alert occurred (refer to Table 22).

TABLE 22. BURNER CONTROL ALERT LOG

DATA	COMMENT
Alert Line	Set by display
Alert Code	Unique Code defining which fault occurred.
Description	Alert description

HISTORY BUTTON

The History button on the Home page serves not only as a button, but also displays Burner Control lockouts, holds, and alerts as they occur. The History button can be selected at any time, regardless of which type of information is displayed, to view history information. Pressing the History button displays a dialog box (see Figure 62 on Page 56) that allows the user to select the type of history to view. The user can also silence an audible alarm generated by the control during a lockout or alert by alarm condition.

This History dialog box provides an exploded view of the status information displayed in the History button (the font is larger). One of the four buttons (OK, Lockouts, Alerts, or Silence) can be selected. If none of these buttons are selected the dialog box closes after 30 seconds.

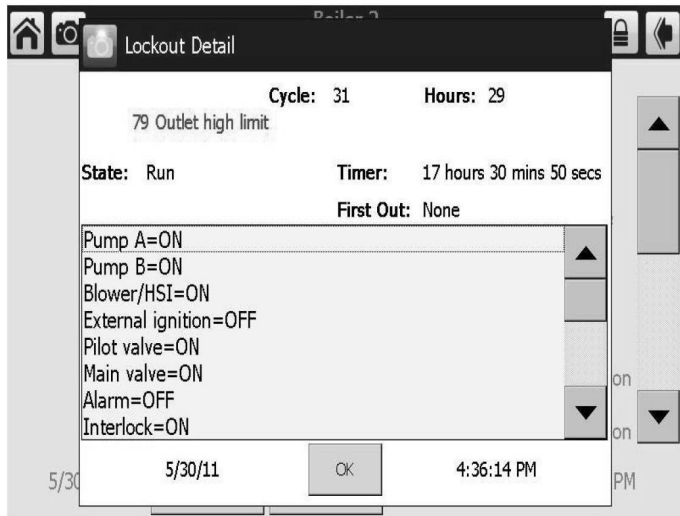

FIGURE 62. EXAMPLE OF HISTORY BUTTON

Two types of historical data can be displayed on the history page: lockout history and alert log.

The entire 15 fault code history is displayed in a scrollable list with the most recent fault displayed first followed by the next most recent fault. Summary information is displayed for each fault entry, including the burner cycle count, fault code, and fault number with description. Detailed information for a specific fault entry that also includes burner control sequence state, burner run-time hours, annunciation status, etc., is viewed by selecting (touching the History line) the lockout entry in the list.

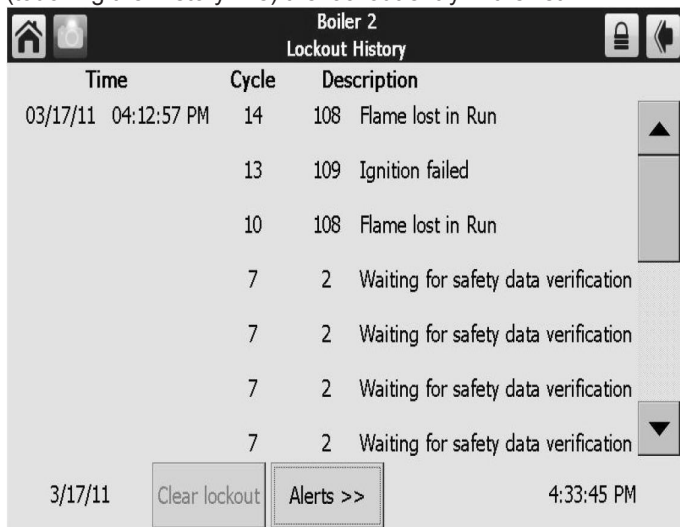

FIGURE 63. EXAMPLE OF LOCKOUT HISTORY

The date and time that each fault occurred is displayed in the lockout history. The lockout timestamp displays in both the lockout summary and detail information.

The Burner Control does not maintain date or time of day information. The date and time stamp is assigned by the OI display. When the OI display first obtains the lockout and alert history from the control (during the display data synchronization), no timestamps are assigned since the times that the lockouts occurred are unknown. All new lockouts that occur after the synchronization are assigned timestamps.

NOTE: The system time can be set in the OI display to ensure that correct timestamps are given to the controls' lockouts and alerts. Power interruptions will require the time to be reset as the display does not have a time backup means.

The Clear Lockout button allows the user to acknowledge and clear (reset) the lockout when in lockout state, much the same as pressing the reset button on the front of the Burner Control.

The user can toggle between displaying the controls' lockout history and alert log by pressing the Alerts or Lockouts button on the bottom of the pages.

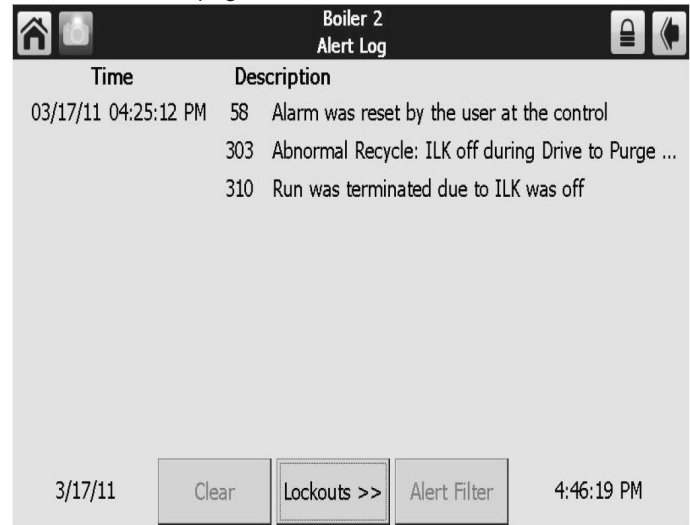

FIGURE 64. EXAMPLE OF ALERT SHOWN

To see additional detail about a lockout or alert, touching on the lockout or alert in the list expands the view of that lockout or alert, as shown in Figure 63 and Figure 64.

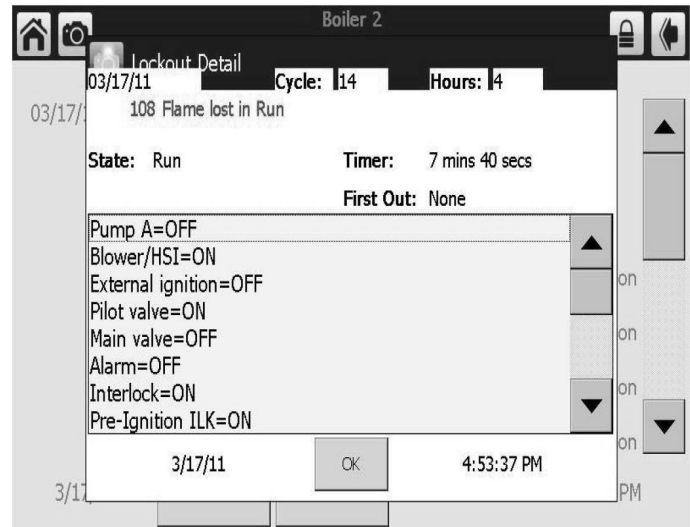

FIGURE 65. CONTROL EXPANDED LOCKOUT DETAIL

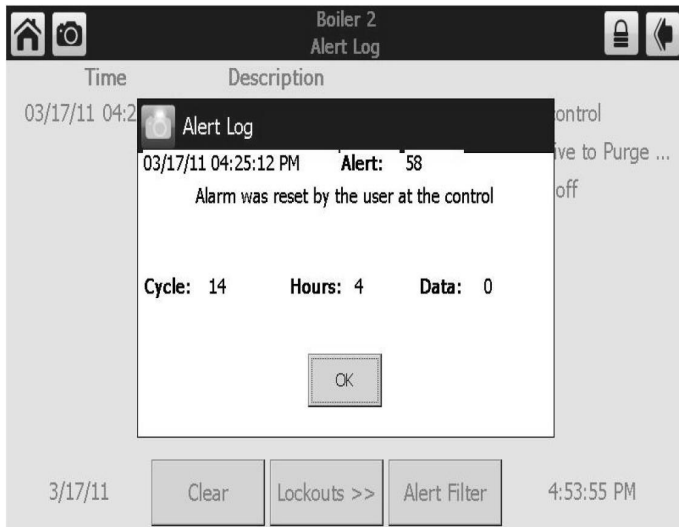

FIGURE 66. CONTROL EXPANDED ALERT DETAIL

OPERATION BUTTON

The operation button displays the Burner Control running operation, including setpoint and firing rate values. From this page the user can change setpoints, manually control the water heater’s firing rate, manually turn pumps on and view annunciation information as shown in Figure 67. If a password is required to change any of the settings on this page, the user can press the Login button to enter the password.

Annunciation information is shown in Figure 68 and Figure 69.

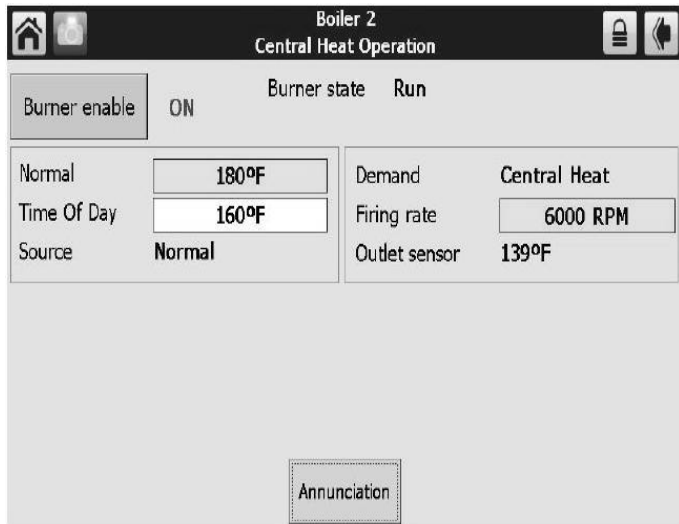

FIGURE 67. OPERATION PAGE

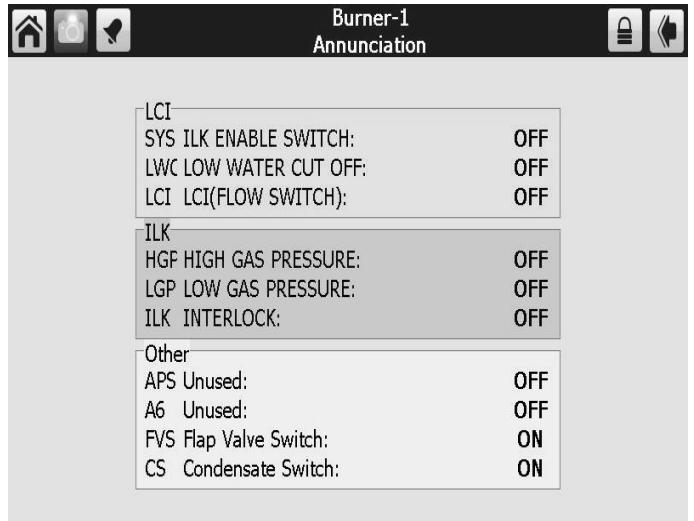

FIGURE 68. PROGRAMMABLE ANNUNCIATION

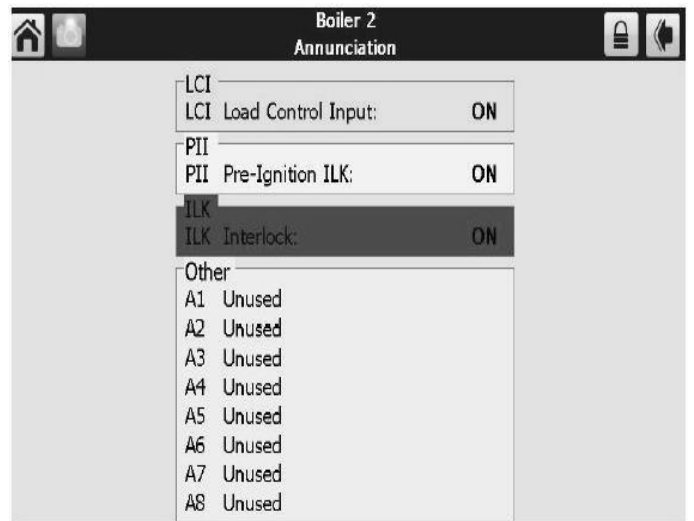

FIGURE 69. PROGRAMMABLE ANNUNCIATION CONT

DIAGNOSTICS BUTTON

The Diagnostics button displays analog and digital I/O status of the Burner Control. A snapshot of the diagnostic status is displayed and updated once per second as it changes in the control.

The digital I/O data is displayed as LEDs that are either on (green) or off (red) (See Figure 70). Not all digital I/O can be displayed at the same time on the page, so a horizontal scroll bar is used to move the view left and right to show all digital I/O data.

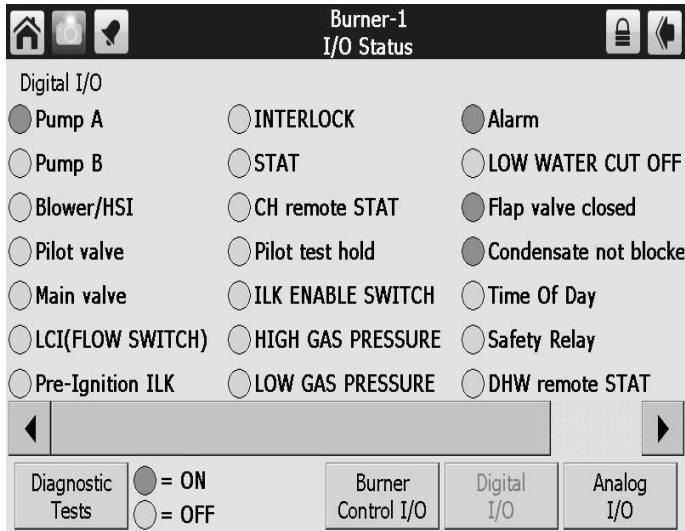

FIGURE 70. DIAGNOSTICS PAGE (DIGITAL I/O)

The control analog I/O can also be viewed on the OI Display. A snapshot of the diagnostic status is displayed and updated as it changes in the control.

The analog I/O data is displayed as bar charts with I/O level represented in the I/O range (see Figure 71). Analog I/O that is not enabled for the installation displays a blank I/O level. Not all analog I/O can be displayed at the same time on the page, so a horizontal scroll bar is used to move the view left and right to show all analog I/O status.

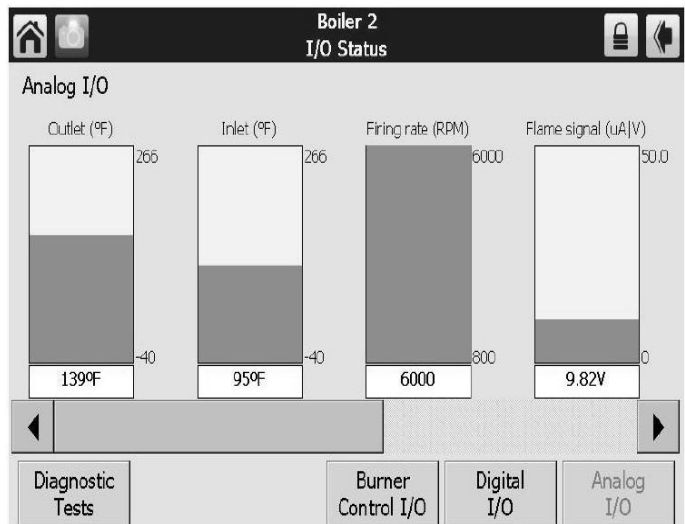

FIGURE 71. DIAGNOSTIC PAGE (ANALOG I/O)

SYSTEM CONFIGURATION (S7999D OI DISPLAY ONLY)

The OI Display has some functions related to general configuration for the control in the end user installation. Pressing the Display Refresh button invokes a search procedure (see Figure 72). A new R7910A Hydronic Control or R7911 Steam Control is identified by “Unknown” status next to its name in the water heater system list (see Figure 73). “Unknown” indicates that configuration data has not been retrieved from the control yet.

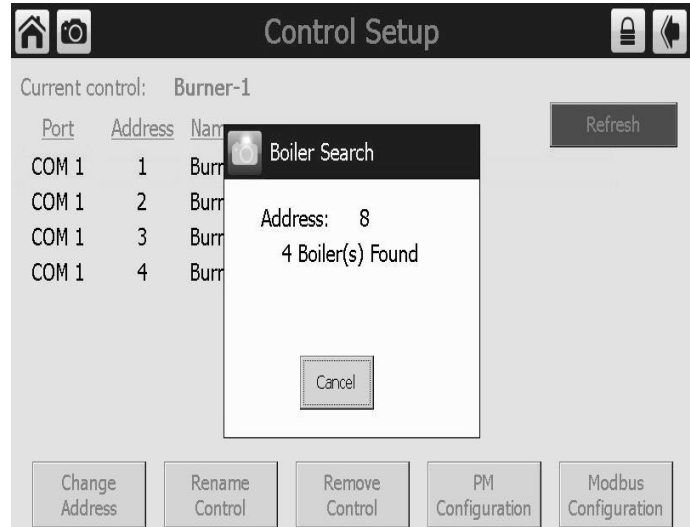

FIGURE 72. SYSTEM REFRESH

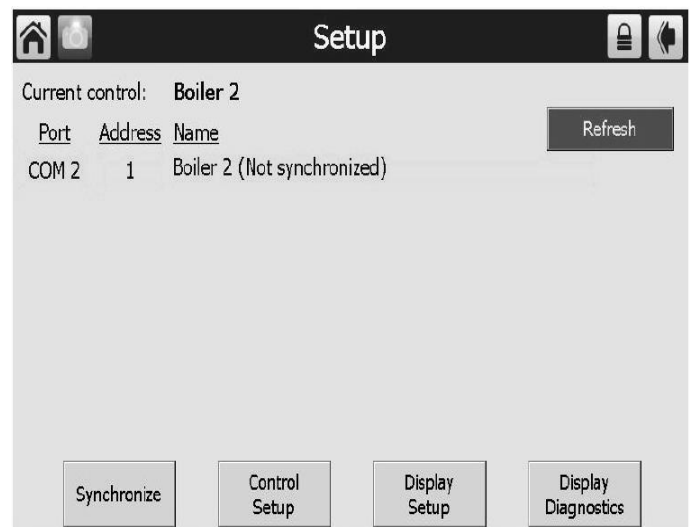

FIGURE 73. SYSTEM CONFIGURATION PAGE

The control connected to the Modbus network is indicated to the user after the search procedure has concluded.

Once the control is located it must be synchronized with the OI Display before it can be displayed. New controls are not displayed on the Home page until this synchronization is performed.

SYSTEM SYNCHRONIZATION (S7999D OI DISPLAY ONLY)

The user can manually synchronize configuration data from the connected controls at any time.

A new control is visible when configuration and status data is gathered from it. This collection procedure takes a few minutes. The control is marked as “Unknown” when no configuration information exists. Normally, control configuration data collection only needs to be performed when the control is initially installed. However, a re synchronization is necessary after the OI Display is reset. See Figure 74.

The user presses the Synchronize button to begin synchronization with the control. See Figure 74.

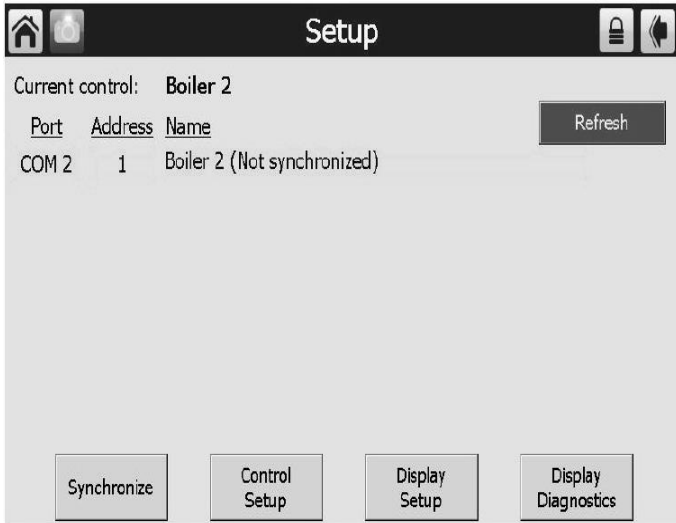

FIGURE 74. SYSTEM SYNCHRONIZATION

Status of the synchronization is reflected in the dialog box. The synchronization can be aborted by selecting the Cancel button.

CONFIGURATION

The Burner Control can be configured from the OI Display. The control configuration is grouped into the functional groups as shown in Table 23.

TABLE 23. FUNCTIONAL CONFIGURATION GROUPS

HYDRONIC CONTROL
System Identification and Access
CH - Central Heat
Outdoor Reset
DHW - Domestic Hot Water
DHW Storage
DHW Plate
Warm Weather Shutdown
Demand Priority
Modulation Configuration
Pump Configuration
Statistics Configuration
High Limit
Stack Limit
Delta T Limits
T-Rise Limit
Heat Exchanger High Limit
Anti-condensation
Frost Protection Configuration
Annunciation Configuration
Burner Control Interlocks
Burner Control Timings and Rates
Burner Control Ignition
Burner Control Flame Failure
System Configuration
Fan Configuration
Sensor Configuration
Lead Lag Slave Configuration
Lead Lag Master Configuration

Most of this configuration is performed by the Service Agent or at A. O. Smith. Each functional group is displayed on the Configuration menu page.

Parameters in functional groups that are not applicable for the installation can be ignored. In some cases, features in a functional group are disabled by default and are enabled when needed for the installation.

TROUBLESHOOTING

To support the recommended Troubleshooting, the R7910 has an Alert File. Review the Alert history for possible trends that may have been occurring prior to the actual Lockout.

Note Column: H= Hold message; L=Lockout message; H or L= either Hold or Lockout depending on Parameter Configuration.

TABLE 24. TROUBLESHOOTING CODES

CODE	DESCRIPTION	RECOMMENDED TROUBLESHOOTING OF LOCKOUT CODES	NOTE
	Safety Data Faults		
1	Unconfigured safety data	<ol style="list-style-type: none"> 1. New Device, complete device configuration and safety verification. 2. If fault repeats, replace module. 	L
2	Waiting for safety data verification	<ol style="list-style-type: none"> 1. Device in Configuration mode and safety parameters need verification and a device needs reset to complete verification. 2. Configuration ended without verification, re enter configuration, verify safety parameters and reset device to complete verification. 3. If fault repeats, replace module. 	L
	Internal Operation Errors		
3	Internal fault: Hardware fault	Internal Fault. <ol style="list-style-type: none"> 1. Reset Module. 2. If fault repeats, replace module. 	H
4	Internal fault: Safety Relay key feedback error		H
5	Internal fault: Unstable power (DCDC) output		H
6	Internal fault: Invalid processor clock		H
7	Internal fault: Safety relay drive error		H
8	Internal fault: Zero crossing not detected		H
9	Internal fault: Flame bias out of range		H
10	Internal fault: Invalid Burner control state		L
11	Internal fault: Invalid Burner control state flag		L
12	Internal fault: Safety relay drive cap short		H
13	Internal fault: PII shorted to ILK		H or L
14	Internal fault: HFS shorted to LCI		H or L
15	Internal fault: Safety relay test failed due to feedback ON		L
16	Internal fault: Safety relay test failed due to safety relay OFF		L
17	Internal fault: Safety relay test failed due to safety relay not OFF		L
18	Internal fault: Safety relay test failed due to feedback not ON		L
19	Internal fault: Safety RAM write		L
20	Internal fault: Flame ripple and overflow		H
21	Internal fault: Flame number of sample mismatch		H
22	Internal fault: Flame bias out of range		H
23	Internal fault: Bias changed since heating cycle starts		H
24	Internal fault: Spark voltage stuck low or high		H
25	Internal fault: Spark voltage changed too much during flame sensing time		H
26	Internal fault: Static flame ripple		H
27	Internal fault: Flame rod shorted to ground detected		H
28	Internal fault: A/D linearity test fails		H
29	Internal fault: Flame bias cannot be set in range		H

CODE	DESCRIPTION	RECOMMENDED TROUBLESHOOTING OF LOCKOUT CODES	NOTE
30	Internal fault: Flame bias shorted to adjacent pin	Internal Fault. 1. Reset Module. 2. If fault repeats, replace module.	H
31	Internal fault: SLO electronics unknown error		H
32 - 46	Internal fault: Safety Key 0 through 14		L
	System Errors		
47	Flame Rod to ground leakage		H
48	Static flame (not flickering)		H
49	24 VAC voltage low/high	1. Check the Module and display connections. 2. Check the Module power supply and make sure that both frequency, voltage and VA meet the specifications.	H
50	Modulation fault	Internal sub-system fault. 1. Review alert messages for possible trends. 2. Correct possible problems. 3. If fault persists, replace module.	H
51	Pump fault		H
52	Motor tachometer fault		H
53	AC inputs phase reversed	1. Check the Module and display connections. 2. Check the Module power supply and make sure that both frequency and voltage meet the specifications. 3. On 24 VAC applications, assure that J4-10 and J8-2 are connected together.	L
54	Safety GVT model ID does not match application's model ID	Contact the qualified service technician.	L
55	Application configuration data block CRC errors	Contact the qualified service technician.	L
56 - 57	RESERVED		
58	Internal fault: HFS shorted to IAS	Internal Fault. 1. Reset Module. 2. If fault repeats, replace module.	L
59	Internal Fault: Mux pin shorted		L
	Normal Event Status		
60	Internal Fault: HFS shorted to LFS		L
61	Anti short cycle	Will not be a lockout fault. Hold Only.	H
62	Fan speed not proved		H
63	LCI OFF	1. Check wiring and correct any faults. 2. Check Interlocks connected to the LCI to assure proper function. 3. Reset and sequence the module; monitor the LCI status. 4. If code persists, replace the module.	H
64	PII OFF	1. Check wiring and correct any faults. 2. Check Preignition Interlock switches to assure proper functioning. 3. Check the valve operation. 4. Reset and sequence the module; monitor the PII status. 5. If code persists, replace the module.	H or L
65	Interrupted Airflow Switch OFF	1. Check wiring and correct any possible shorts. 2. Check airflow switches to assure proper functioning. 3. Check the fan/blower operation. 4. Reset and sequence the module; monitor the airflow status. 5. If code persists, replace the module.	H or L
66	Interrupted Airflow Switch ON		H or L

CODE	DESCRIPTION	RECOMMENDED TROUBLESHOOTING OF LOCKOUT CODES	NOTE
67	ILK OFF	<ol style="list-style-type: none"> 1. Check wiring and correct any possible shorts. 2. Check Interlock (ILK) switches to assure proper function. 3. Verify voltage through the interlock string to the interlock input with a voltmeter. 4. If steps 1-3 are correct and the fault persists, replace the module. 	H or L
68	ILK ON		H or L
69	Pilot test hold	<ol style="list-style-type: none"> 1. Verify Run/Test is changed to Run. 2. Reset Module. 3. If fault repeats, replace module. 	H
70	Wait for leakage test completion	<ol style="list-style-type: none"> 1. Internal Fault. Reset Module. 2. If fault repeats, replace module. 	H
71 - 77	RESERVED		
78	Demand Lost in Run	<ol style="list-style-type: none"> 1. Check wiring and correct any possible errors. 2. If previous steps are correct and fault persists, replace the module. 	H
79	Outlet high limit	<ol style="list-style-type: none"> 1. Check wiring and correct any possible errors. 2. Replace the Outlet high limit. 3. If previous steps are correct and fault persists, replace the module. 	H or L
80	DHW high limit	<ol style="list-style-type: none"> 1. Check wiring and correct any possible errors. 2. Replace the DHW high limit. 3. If previous steps are correct and fault persists, replace the module. 	H or L
81	Delta T limit	<ol style="list-style-type: none"> 1. Check Inlet and Outlet sensors and pump circuits for proper operation. 2. Recheck the Delta T Limit to confirm proper setting. 3. If previous steps are correct and fault persists, replace the module. 	H or L
82	Stack limit	<ol style="list-style-type: none"> 1. Check wiring and correct any possible errors. 2. Replace the Stack high limit. 3. If previous steps are correct and fault persists, replace the module. 	H or L
83	Delta T exchanger/outlet limit	Not Applicable.	H or L
84	Delta T inlet/exchanger limit	Not Applicable.	H or L
85	Inlet/outlet inversion limit	Not Applicable.	H or L
86	Exchanger/outlet inversion limit	Not Applicable.	H or L
87	Inlet/exchanger inversion limit	Not Applicable.	H or L
88	Outlet T-rise limit	Check for adequate flow.	H or L
89	Exchanger T-rise limit	Not Applicable.	H or L
90	Heat exchanger high limit	Not Applicable.	H or L
	Sensor Faults		
91	Inlet sensor fault	<ol style="list-style-type: none"> 1. Check wiring and correct any possible errors. 2. Replace the Inlet sensor. 3. If previous steps are correct and fault persists, replace the module. 	H
92	Outlet sensor fault	<ol style="list-style-type: none"> 1. Check wiring and correct any possible errors. 2. Replace the Outlet sensor. 3. If previous steps are correct and fault persists, replace the module. 	H
93	DHW sensor fault	<ol style="list-style-type: none"> 1. Check wiring and correct any possible errors. 2. Replace the DHW sensor. 3. If previous steps are correct and fault persists, replace the module. 	H

CODE	DESCRIPTION	RECOMMENDED TROUBLESHOOTING OF LOCKOUT CODES	NOTE
94	Header sensor fault	<ol style="list-style-type: none"> 1. Check wiring and correct any possible errors. 2. Replace the header sensor. 3. If previous steps are correct and fault persists, replace the module. 	H
95	Stack sensor fault	<ol style="list-style-type: none"> 1. Check wiring and correct any possible errors. 2. Replace the stack sensor. 3. If previous steps are correct and fault persists, replace the module. 	H
96	Outdoor sensor fault	<ol style="list-style-type: none"> 1. Check wiring and correct any possible errors. 2. Replace the outdoor sensor. 3. If previous steps are correct and fault persists, replace the module. 	H
97	Internal Fault: A2D mismatch.	Internal Fault.	L
98	Internal Fault: Exceeded VSNSR voltage	<ol style="list-style-type: none"> 1. Reset Module. 2. If fault repeats, replace module. 	L
99	Internal Fault: Exceeded 28V voltage tolerance		L
100	Pressure Sensor Fault	<ol style="list-style-type: none"> 1. Verify the Pressure Sensor is a 4-20 ma source. 2. Check wiring and correct any possible errors. 3. Test Pressure Sensor for correct operation. 4. Replace the Pressure sensor. 5. If previous steps are correct and fault persists, replace the module. 	H
101-104	RESERVED		
	Flame Operation Faults		
105	Flame detected out of sequence	<ol style="list-style-type: none"> 1. Check that flame is not present in the combustion chamber. Correct any errors. 2. Make sure that the flame detector is wired to the correct terminal. 3. Make sure the F & G wires are protected from stray noise pickup. 4. Reset and sequence the module, if code reappears, replace the flame detector. 5. Reset and sequence the module, if code reappears, replace the module. 	H or L
106	Flame lost in MFEP	<ol style="list-style-type: none"> 1. Check pilot valve (Main Valve for DSI) wiring and operation - correct any errors. 	L
107	Flame lost early in run	<ol style="list-style-type: none"> 2. Check the fuel supply. 	L
108	Flame lost in run	<ol style="list-style-type: none"> 3. Check fuel pressure and repeat turndown tests. 	L
109	Ignition failed	<ol style="list-style-type: none"> 4. Check ignition transformer electrode, flame detector, flame detector siting or flame rod position. 5. If steps 1 through 4 are correct and the fault persists, replace the module. 	L
110	Ignition failure occurred	Hold time of recycle and hold option. Will not be a lockout fault. Hold Only.	H
111	Flame current lower than WEAK threshold	Internal hardware test. Not a lockout,	H
112	Pilot test flame timeout	Interrupted Pilot or DSI application and flame lost when system in "test" mode. <ol style="list-style-type: none"> 1. Reset the module to restart. 	L
113	Flame circuit timeout	Flame sensed during Initiate or off cycle, hold 240 seconds, if present after 240 seconds, lockout.	L
114-116	RESERVED		
117	Condensate Fault	<ol style="list-style-type: none"> 1. Check the condensate trap at the back of the water heater for any blockage. 2. Check the exhaust vent piping for any blockage. 	L
118-121	RESERVED		
	Rate Proving Faults		

CODE	DESCRIPTION	RECOMMENDED TROUBLESHOOTING OF LOCKOUT CODES	NOTE
122	Lightoff rate proving failed	<ol style="list-style-type: none"> 1. Check wiring and correct any potential wiring errors. 2. Check VFDs ability to change speeds. 3. Change the VFD 4. If the fault persists, replace the module. 	L
123	Purge rate proving failed		L
124	High fire switch OFF	<ol style="list-style-type: none"> 1. Check wiring and correct any potential wiring errors. 2. Check High Fire Switch to assure proper function (not welded or jumpered). 3. Manually drive the motor to the High Fire position and adjust the HF switch while in this position and verify voltage through the switch to the HFS input with a voltmeter. 4. If steps 1-3 are correct and the fault persists, replace the module. 	H
125	High fire switch stuck ON		H
126	Low fire switch OFF	<ol style="list-style-type: none"> 1. Check wiring and correct any potential wiring errors. 2. Check Low Fire Switch to assure proper function (not welded or jumpered). 3. Manually drive the motor to the High Fire position and adjust the LF switch while in this position and verify voltage through the switch to the LFS input with a voltmeter. 4. If steps 1-3 are correct and the fault persists, replace the module. 	H
127	Low fire switch stuck ON		H or L
128	Fan speed failed during prepurge	<ol style="list-style-type: none"> 1. Check wiring and correct any potential wiring errors. 2. Check VFDs ability to change speeds. 3. Change the VFD 4. If the fault persists, replace the module. 	H or L
129	Fan speed failed during preignition		H or L
130	Fan speed failed during ignition		H or L
131	Fan movement detected during standby		H
132	Fan speed failed during run		H
133-135	RESERVED		
	Start Check Faults		
136	Interrupted Airflow Switch failed to close	<ol style="list-style-type: none"> 1. Check wiring and correct any possible wiring errors. 2. Check Interrupted Airflow switch(es) to assure proper function. 3. Verify voltage through the airflow switch to the IAS input with a voltmeter. 4. If steps 1-3 are correct and the fault persists, replace the module. 	H
137	ILK failed to close	<ol style="list-style-type: none"> 1. Check wiring and correct any possible shorts. 2. Check Interlock (ILK) switches to assure proper function. 3. Verify voltage through the interlock string to the interlock input with a voltmeter. 4. If steps 1-3 are correct and the fault persists, replace the module. 	H
138-142	RESERVED		
	FAULT CODES 149 THROUGH 165 ARE OEM SPECIFIC FAULT CODES.		
143	Internal fault: Flame bias out of range 1	Contact the qualified service technician.	L
144	Internal fault: Flame bias out of range 2	Contact the qualified service technician.	L
145	Internal fault: Flame bias out of range 3	Contact the qualified service technician.	L
146	Internal fault: Flame bias out of range 4	Contact the qualified service technician.	L
147	Internal fault: Flame bias out of range 5	Contact the qualified service technician.	L
148	Internal fault: Flame bias out of range 6	Contact the qualified service technician.	L

CODE	DESCRIPTION	RECOMMENDED TROUBLESHOOTING OF LOCKOUT CODES	NOTE
149	Flame detected	OEM Specific 1. Holds if flame detected during Safe Start check up to Flame Establishing period.	H or L
150	Flame not detected	OEM Specific 1. Sequence returns to standby and restarts sequence at the beginning of Purge after the HF switch opens. If flame detected during Safe Start check up to Flame Establishing period.	H
151	High fire switch ON	OEM Specific 1. Check wiring and correct any potential wiring errors. 2. Check High Fire Switch to assure proper function (not welded or jumpered). 3. Manually drive the motor to the High Fire position and adjust the HF switch while in this position and verify voltage through the switch to the HFS input with a voltmeter. 4. If steps 1-3 are correct and the fault persists, replace the module.	H or L
152	Combustion pressure ON	OEM Specific 1. Check wiring and correct any errors. 2. Inspect the Combustion Pressure Switch to make sure it is working correctly. 3. Reset and sequence the relay module. 4. During STANDBY and PREPURGE, measure the voltage between Terminal J6-5 and L2 (N). Supply voltage should be present. If not, the lockout switch is defective and needs replacing. 5. If the fault persists, replace the relay module.	H or L
153	Combustion pressure Off		H or L
154	Purge Fan switch On	OEM Specific 1. Purge fan switch is on when it should be off.	H or L
155	Purge Fan switch Off		H
156	Combustion pressure and Flame ON	OEM Specific 1. Check that flame is not present in the combustion chamber. Correct any errors. 2. Make sure that the flame detector is wired to the correct terminal. 3. Make sure the F & G wires are protected from stray noise pickup. 4. Reset and sequence the module, if code reappears, replace the flame detector.	H or L
157	Combustion pressure and Flame OFF		L
158	Main valve ON	OEM Specific 1. Check Main Valve terminal wiring and correct any errors. 2. Reset and sequence the module. If fault persist, replace the module.	L
159	Main valve OFF		L
160	Ignition ON	OEM Specific 1. Check Ignition terminal wiring and correct any errors. 2. Reset and sequence the module. If fault persist, replace the module.	L
161	Ignition OFF		L
162	Pilot valve ON	OEM Specific 1. Check Pilot Valve terminal wiring and correct any errors. 2. Reset and sequence the module. If fault persist, replace the module.	L
163	Pilot valve OFF		L

CODE	DESCRIPTION	RECOMMENDED TROUBLESHOOTING OF LOCKOUT CODES	NOTE
164	Block intake ON	OEM Specific	L
165	Block intake OFF	<ol style="list-style-type: none"> 1. Check wiring and correct any errors. 2. Inspect the Block Intake Switch to make sure it is working correctly. 3. Reset and sequence the module. 4. During Standby and Purge, measure the voltage across the switch. Supply voltage should be present. If not, the Block Intake Switch is defective and needs replacing. 5. If the fault persists, replace the relay module. 	L
166-171	RESERVED		
	Feedback		
172	Main relay feedback incorrect	Internal Fault.	L
173	Pilot relay feedback incorrect	<ol style="list-style-type: none"> 1. Reset Module. 2. If fault repeats, replace module. 	L
174	Safety relay feedback incorrect		L
175	Safety relay open		L
176	Main relay ON at safe start check		L
177	Pilot relay ON at safe start check		L
178	Safety relay ON at safe start check		L
179-183	RESERVED		
	Parameter Faults		
184	Invalid BLOWER/HSI output setting	<ol style="list-style-type: none"> 1. Return to Configuration mode and recheck selected parameters, reverify and reset module. 2. If fault repeats, verify electrical grounding. 3. If fault repeats, replace module. 	L
185	Invalid Delta T limit enable setting		L
186	Invalid Delta T limit response setting		L
187	Invalid DHW high limit enable setting		L
188	Invalid DHW high limit response setting		L
189	Invalid Flame sensor type setting		L
190	Invalid interrupted air switch enable setting		L
191	Invalid interrupted air switch start check enable setting		L
192	Invalid igniter on during setting		L
193	Invalid ignite failure delay setting		L
194	Invalid ignite failure response setting	<ol style="list-style-type: none"> 1. Return to Configuration mode and recheck selected parameters, reverify and reset module. 2. If fault repeats, verify electrical grounding. 3. If fault repeats, replace module. 	L
195	Invalid ignite failure retries setting		L
196	Invalid ignition source setting		L
197	Invalid interlock open response setting		L
198	Invalid interlock start check setting		L
199	Invalid LCI enable setting		L
200	Invalid lightoff rate setting		L
201	Invalid lightoff rate proving setting		L
202	Invalid Main Flame Establishing Period time		L
203	Invalid MFEP flame failure response setting		L
204	Invalid NTC sensor type setting		L
205	Invalid Outlet high limit response setting		L
206	Invalid Pilot Flame Establishing Period setting		L
207	Invalid PII enable setting		L
208	Invalid pilot test hold setting		L
209	Invalid Pilot type setting		L
210	Invalid Postpurge time setting		L
211	Invalid Power up with lockout setting		L

CODE	DESCRIPTION	RECOMMENDED TROUBLESHOOTING OF LOCKOUT CODES	NOTE
212	Invalid Preignition time setting	<ol style="list-style-type: none"> Return to Configuration mode and recheck selected parameters, reverify and reset module. If fault repeats, verify electrical grounding. If fault repeats, replace module. 	L
213	Invalid Prepurge rate setting		L
214	Invalid Prepurge time setting		L
215	Invalid Purge rate proving setting		L
216	Invalid Run flame failure response setting		L
217	Invalid Run stabilization time setting		L
218	Invalid Stack limit enable setting		L
219	Invalid Stack limit response setting		L
220	Unconfigured Delta T limit setpoint setting		L
221	Unconfigured DHW high limit setpoint setting		L
222	Unconfigured Outlet high limit setpoint setting		L
223	Unconfigured Stack limit setpoint setting		L
224	Invalid DHW demand source setting		L
225	Invalid Flame threshold setting		L
226	Invalid Outlet high limit setpoint setting		L
227	Invalid DHW high limit setpoint setting		L
228	Invalid Stack limit setpoint setting		L
229	Invalid Modulation output setting		L
230	Invalid CH demand source setting		L
231	Invalid Delta T limit delay setting		L
232	Invalid Pressure sensor type setting		L
233	Invalid IAS closed response setting		L
234	Invalid Outlet high limit enable setting		Contact the qualified service technician.
235	Invalid Outlet connector type setting	Contact the qualified service technician.	L
236	Invalid Inlet connector type setting	Contact the qualified service technician.	L
237	Invalid DHW connector type setting	Contact the qualified service technician.	L
238	Invalid Stack connector type setting	Contact the qualified service technician.	L
239	Invalid S2 (J8-6) connector type setting	Contact the qualified service technician.	L
240	Invalid S5 (J8-11) connector type setting	Contact the qualified service technician.	L
241	Exchanger sensor not allowed with stack connector setting	Not Applicable.	L
242	Invalid DHW auto detect configuration	Not Applicable.	L
243	Invalid UV with spark interference not compatible with Ignitor on throughout PFEP	Contact the qualified service technician.	L
244	Internal fault: Safety relay test invalid state	Contact the qualified service technician.	L
245	Invalid Outlet connector type setting for Trise	Contact the qualified service technician.	L
246	4-20mA cannot be used for both modulation and setpoint control	Contact the qualified service technician.	L
247	Invalid ILK bounce detection enable	Not Applicable.	L
248	Invalid forced recycle interval	Not Applicable.	L
249	STAT cannot be demand source when Remote Stat is enabled	Not Applicable.	L
250	Invalid Fan speed error response	<ol style="list-style-type: none"> Check fan cables secured properly. If fault persists contact the qualified service technician. 	L
251-255	RESERVED		

TABLE 25. ALERTS

CODE	DESCRIPTION
	EE Management Faults
0	None (No alert)
1	Alert PCB was restored from factory defaults
2	Safety configuration parameters were restored from factory defaults
3	Configuration parameters were restored from factory defaults
4	Invalid Factory Invisibility PCB was detected
5	Invalid Factory Range PCB was detected
6	Invalid range PCB record has been dropped
7	EEPROM lockout history was initialized
8	Switched application annunciation data blocks
9	Switched application configuration data blocks
10	Configuration was restored from factory defaults
11	Backup configuration settings was restored from active configuration
12	Annunciation configuration was restored from factory defaults
13	Annunciation configuration was restored from backup
14	Safety group verification table was restored from factory defaults
15	Safety group verification table was updated
16	Invalid Parameter PCB was detected
17	Invalid Range PCB was detected
	System Parameter Errors
18	Alarm silence time exceeded maximum
19	Invalid safety group verification table was detected
20	Backdoor Password could not be determined
21	Invalid safety group verification table was not accepted
22	CRC errors were found in application configuration data blocks
23	Backup Alert PCB was restored from active one
24	RESERVED
25	Lead Lag operation switch was turned OFF
26	Lead Lag operation switch was turned ON
27	Safety processor was reset
28	Application processor was reset
29	Burner switch was turned OFF
30	Burner switch was turned ON
31	Program Module (PM) was inserted into socket
32	Program Module (PM) was removed from socket
33	Alert PCB was configured
34	Parameter PCB was configured
35	Range PCB was configured
36	Program Module (PM) incompatible with product was inserted into socket

CODE	DESCRIPTION
37	Program Module application parameter revision differs from application processor
38	Program Module safety parameter revision differs from safety processor
39	PCB incompatible with product contained in Program Module
40	Parameter PCB in Program Module is too large for product
41	Range PCB in Program Module was too large for product
42	Alert PCB in Program Module was too large for product
43	IAS start check was forced on due to IAS enabled
	System Operation Faults
44	Low voltage was detected in safety processor
45	High line frequency occurred
46	Low line frequency occurred
47	Invalid subsystem reset request occurred
48	Write large enumerated Modbus register value was not allowed
49	Maximum cycle count was reached
50	Maximum hours count was reached
51	Illegal Modbus write was attempted
52	Modbus write attempt was rejected (NOT ALLOWED)
53	Illegal Modbus read was attempted
54	Safety processor brown-out reset occurred
55	Application processor watchdog reset occurred
56	Application processor brown-out reset occurred
57	Safety processor watchdog reset occurred
58	Alarm was reset by the user at the control
	Demand/Rate Command Faults
59	Burner control firing rate was > absolute max rate
60	Burner control firing rate was < absolute min rate
61	Burner control firing rate was invalid, % vs. RPM
62	Burner control was firing with no fan request
63	Burner control rate (nonfiring) was > absolute max rate
64	Burner control rate (nonfiring) was < absolute min rate
65	Burner control rate (nonfiring) was absent
66	Burner control rate (nonfiring) was invalid, % vs.RPM
67	Fan off cycle rate was invalid, % vs. RPM
68	Setpoint was overridden due to sensor fault
69	Modulation was overridden due to sensor fault
70	No demand source was set due to demand priority conflicts
71-73	RESERVED

CODE	DESCRIPTION
	Fan Parameter Errors
74	Periodic Forced Recycle
75	Absolute max fan speed was out of range
76	Absolute min fan speed was out of range
77	Fan gain down was invalid
78	Fan gain up was invalid
79	Fan minimum duty cycle was invalid
80	Fan pulses per revolution was invalid
81	Fan PWM frequency was invalid
82-83	RESERVED
	Modulation Parameter Errors
84	Lead Lag CH 4-20 mA water temperature setting
85	No Lead Lag add stage error threshold was configured
86	No Lead Lag add stage detection time was configured
87	No Lead Lag drop stage error threshold was configured
88	No Lead Lag drop stage detection time was configured
89	RESERVED
90	Modulation output type was invalid
91	Firing rate control parameter was invalid
92	Forced rate was out of range vs. min/max modulation
93	Forced rate was invalid, % vs. RPM
94	Slow start ramp value was invalid
95	Slow start degrees value was invalid
96	Slow start was ended due to outlet sensor fault
97	Slow start was end due to reference setpoint fault
98	CH max modulation rate was invalid, % vs. RPM
99	CH max modulation rate was > absolute max rate
100	CH modulation range (max minus min) was too small (< 4% or 40 RPM)
101	DHW max modulation rate was invalid, % vs. RPM
102	DHW max modulation rate was > absolute max rate
103	DHW modulation range (max minus min) was too small (< 4% or 40 RPM)
104	Min modulation rate was < absolute min rate
105	Min modulation rate was invalid, % vs. RPM
106	Manual rate was invalid, % vs. RPM
107	Slow start enabled, but forced rate was invalid
108	Analog output hysteresis was invalid
109	Analog modulation output type was invalid
110	IAS open rate differential was invalid
111	IAS open step rate was invalid
112	MIX max modulation rate was invalid, % vs. RPM
113	MIX max modulation rate was > absolute max or < absolute min rates

CODE	DESCRIPTION
114	MIX modulation range (max minus min) was too small (< 4% or 40 RPM)
	Modulation Operation Faults
115	Fan was limited to its minimum duty cycle
116	Manual rate was > CH max modulation rate
117	Manual rate was > DHW max modulation rate
118	Manual rate was < min modulation rate
119	Manual rate in Standby was > absolute max rate
120	Modulation commanded rate was > CH max modulation rate
121	Modulation commanded rate was > DHW max modulation rate
122	Modulation commanded rate was < min modulation rate
123	Modulation rate was limited due to outlet limit
124	Modulation rate was limited due to Delta-T limit
125	Modulation rate was limited due to stack limit
126	Modulation rate was limited due to anticondensation
127	Fan Speed out of range in RUN
128	Modulation rate was limited due to IAS was open
129	Slow start ramp setting of zero will result in no modulation rate change
130	No forced rate was configured for slow start ramp
	CH parameter Errors
131	CH demand source was invalid
132	CH P-gain was invalid
133	CH I-gain was invalid
134	CH D-gain was invalid
135	CH OFF hysteresis was invalid
136	CH ON hysteresis was invalid
137	CH sensor type was invalid
138	CH hysteresis step time was invalid
139	CH remote control parameter was invalid
140	CH ODR not allowed with remote control
141	Steam P-gain was invalid
142	Steam I-gain was invalid
143	Steam D-gain was invalid
144	Steam OFF hysteresis was invalid
145	Steam ON hysteresis was invalid
	CH Operation Faults
146	CH control was suspended due to fault
147	CH header temperature was invalid
148	CH outlet temperature was invalid
149	CH steam pressure was invalid
	CH Parameter errors (continued)
150	Steam setpoint source parameter was invalid
151	Minimum water temperature parameter was greater than setpoint

CODE	DESCRIPTION
152	Minimum water temperature parameter was greater than time of day setpoint
153	Minimum pressure parameter was greater than setpoint
154	Minimum pressure parameter was greater than time of day setpoint
155	CH modulation rate source parameter was invalid
156	Steam modulation rate source parameter was invalid
	DHW Parameter Errors
157	DHW demand source was invalid
158	DHW P-gain was invalid
159	DHW I-gain was invalid
160	DHW D-gain was invalid
161	DHW OFF hysteresis was invalid
162	DHW ON hysteresis was invalid
163	DHW hysteresis step time was invalid
164	DHW sensor type was invalid
165	Inlet sensor type was invalid for DHW
166	Outlet sensor type was invalid for DHW
167	DHW Storage OFF hysteresis was invalid
168	DHW Storage ON hysteresis was invalid
169	DHW modulation sensor type was invalid
170	DHW modulation sensor was not compatible for AUTO mode
	DHW Operation Faults
171	DHW control was suspended due to fault
172	DHW temperature was invalid
173	DHW inlet temperature was invalid
174	DHW outlet temperature was invalid
175	DHW high limit must be disabled for AUTO mode
176	DHW sensor type was not compatible for AUTO mode
177	DHW priority source setting was invalid
178	DHW priority method setting was invalid
	CH Operation Faults (continued)
179	CH S5 (J8 terminal 11) sensor was invalid
180	CH inlet temperature was invalid
181	CH S10 (J10 terminal 7) sensor was invalid
182	Lead Lag CH setpoint source was invalid
	Lead Lag Parameter errors
183	Lead Lag P-gain was invalid
184	Lead Lag I-gain was invalid
185	Lead Lag D-gain was invalid
186	Lead Lag OFF hysteresis was invalid
187	Lead Lag ON hysteresis was invalid
188	Lead Lag slave enable was invalid
189	Lead Lag hysteresis step time was invalid
190	No Lead lag Modbus port was assigned

CODE	DESCRIPTION
191	Lead Lag base load common setting was invalid
192	Lead Lag DHW demand switch setting was
193	Lead Lag Mix demand switch setting was invalid
194	Lead Lag modulation sensor setting was invalid
195	Lead Lag backup modulation sensor setting was invalid
196	Lead Lag slave mode setting was invalid
197	Lead Lag rate allocation setting was invalid
198	Lead selection setting was invalid
199	Lag selection setting was invalid
200	Lead Lag slave return setting was invalid
201	Lead Lag add stage method setting was invalid
202	STAT may not be a Lead Lag CH demand source when Remote Stat is enabled
203	Lead Lag base load rate setting was invalid
	Lead Lag Operation Faults
204	Lead Lag master was suspended due to fault
205	Lead Lag slave was suspended due to fault
206	Lead Lag header temperature was invalid
207	Lead Lag was suspended due to no enabled Program Module installed
208	Lead Lag slave session has timed out
209	Too many Lead Lag slaves were detected
210	Lead Lag slave was discovered
211	Incompatible Lead Lag slave was discovered
212	No base load rate was set for Lead Lag slave
213	Lead Lag slave unable to fire before demand to fire delay expired
214	Adding Lead Lag slave aborted due to add requirement change
215	No Lead Lag slaves available to service demand
216	No Lead Lag active service was set due to demand priority conflicts
217	No Lead Lag add stage method was specified
218	No Lead Lag drop stage method was specified
219	Using backup lead lag header sensor due to sensor failure
	Frost Protection Faults
220	Lead Lag frost protection rate was invalid
221	Lead Lag drop stage method setting was invalid
222	CH frost protection temperature was invalid
223	CH frost protection inlet temperature was invalid
224	DHW frost protection temperature was invalid
225-226	RESERVED
227	DHW priority override time was not derated due to invalid outdoor temperature
228	Warm weather shutdown was not checked due to invalid outdoor temperature
229	Lead Lag slave communication timeout
230	RESERVED

CODE	DESCRIPTION
231	Lead Lag CH setpoint was invalid
232	Lead Lag CH time of day setpoint was invalid
233	LL outdoor temperature was invalid
234	Lead Lag ODR time of day setpoint was invalid
235	Lead Lag ODR time of day setpoint exceeded normal setpoint
236	Lead Lag ODR max outdoor temperature was invalid
237	Lead Lag ODR min outdoor temperature was invalid
238	Lead Lag ODR low water temperature was invalid
239	Lead Lag ODR outdoor temperature range was too small (minimum 12°C / 22°F)
240	Lead Lag ODR water temperature range was too small (minimum 12°C / 22°F)
241	Lead Lag DHW setpoint was invalid
242	Lead Lag Mix setpoint was invalid
243	Lead Lag CH demand switch was invalid
244	Lead Lag CH setpoint source was invalid
245	RESERVED
246	CH setpoint was invalid
247	CH time of day setpoint was invalid
248	CH outdoor temperature was invalid
249	CH ODR time of day setpoint was invalid
250	CH ODR time of day setpoint exceeds normal setpoint
251	CH max outdoor setpoint was invalid
252	CH min outdoor setpoint was invalid
253	CH min water setpoint was invalid
254	CH outdoor temperature range was too small
255	CH water temperature range was too small
256	Steam setpoint was invalid
257	Steam time of day setpoint was invalid
258	Steam minimum pressure was invalid
259	CH ODR min water temperature was invalid
260	RESERVED
261	DHW setpoint was invalid
262	DHW time of day setpoint was invalid
263	DHW storage setpoint was invalid
264	STAT may not be a DHW demand source when Remote Stat is enabled
265-266	RESERVED
267	STAT may not be a CH demand source when Remote Stat is enabled
268	CH 4mA water temperature setting was invalid
269	CH 20mA water temperature setting was invalid
270	Steam 4mA water temperature setting was invalid
271	Steam 20mA water temperature setting was invalid
272	Abnormal Recycle: Pressure sensor fault
273	Abnormal Recycle: Safety relay drive test failed

CODE	DESCRIPTION
274	Abnormal Recycle: Demand off during Pilot Flame Establishing Period
275	Abnormal Recycle: LCI off during Drive to Purge Rate
276	Abnormal Recycle: LCI off during Measured Purge Time
277	Abnormal Recycle: LCI off during Drive to Lightoff Rate
278	Abnormal Recycle: LCI off during Pre-Ignition test
279	Abnormal Recycle: LCI off during Pre-Ignition time
280	Abnormal Recycle: LCI off during Main Flame Establishing Period
281	Abnormal Recycle: LCI off during Ignition period
282	Abnormal Recycle: Demand off during Drive to Purge Rate
283	Abnormal Recycle: Demand off during Measured Purge Time
284	Abnormal Recycle: Demand off during Drive to Lightoff Rate
285	Abnormal Recycle: Demand off during Pre-Ignition test
286	Abnormal Recycle: Demand off during Pre-Ignition time
287	Abnormal Recycle: Flame was on during Safe Check
288	Abnormal Recycle: Flame was on during Drive to Purge Rate
289	Abnormal Recycle: Flame was on during Measured Purge Time
290	Abnormal Recycle: Flame was on during Drive to Lightoff Rate
291	Abnormal Recycle: Flame was not on at end of Ignition period
292	Abnormal Recycle: Flame was lost during Main Flame Establishing Period
293	Abnormal Recycle: Flame was lost early in Run
294	Abnormal Recycle: Flame was lost during Run
295	Abnormal Recycle: Leakage test failed
296	Abnormal Recycle: Interrupted air flow switch was off during Drive to Purge Rate
297	Abnormal Recycle: Interrupted air flow switch was off during Measured Purge Time
298	Abnormal Recycle: Interrupted air flow switch was off during Drive to Lightoff Rate
299	Abnormal Recycle: Interrupted air flow switch was off during Pre-Ignition test
300	Abnormal Recycle: Interrupted air flow switch was off during Pre-Ignition time
301	Abnormal Recycle: Interrupted air flow switch was off during Main Flame Establishing Period
302	Abnormal Recycle: Ignition failed due to interrupted air flow switch was off
303	Abnormal Recycle: ILK off during Drive to Purge Rate

CODE	DESCRIPTION
304	Abnormal Recycle: ILK off during Measured Purge Time
305	Abnormal Recycle: ILK off during Drive to Lightoff Rate
306	Abnormal Recycle: ILK off during Pre-Ignition test
307	Abnormal Recycle: ILK off during Pre-Ignition time
308	Abnormal Recycle: ILK off during Main Flame Establishing Period
309	Abnormal Recycle: ILK off during Ignition period
310	Run was terminated due to ILK was off
311	Run was terminated due to interrupted air flow switch was off
312	Stuck reset switch
313	Run was terminated due to fan failure
314	Abnormal Recycle: Fan failed during Drive to Purge Rate
315	Abnormal Recycle: Fan failed during Measured Purge Time
316	Abnormal Recycle: Fan failed during Drive to Lightoff Rate
317	Abnormal Recycle: Fan failed during Pre-Ignition test
318	Abnormal Recycle: Fan failed during Pre-Ignition time
319	Abnormal Recycle: Fan failed during Ignition period
320	Abnormal Recycle: Fan failed during Main Flame Establishing Period
321	Abnormal Recycle: Main Valve off after 10 seconds of RUN
322	Abnormal Recycle: Pilot Valve off after 10 seconds of RUN
323	Abnormal Recycle: Safety Relay off after 10 seconds of RUN
324	Abnormal Recycle: Hardware flame bias
325	Abnormal Recycle: Hardware static flame
326	Abnormal Recycle: Hardware flame current invalid
327	Abnormal Recycle: Hardware flame rod short
328	Abnormal Recycle: Hardware invalid power
329	Abnormal Recycle: Hardware invalid AC line
330	Abnormal Recycle: Hardware SLO flame ripple
330	Abnormal Recycle: Hardware SLO flame sample
332	Abnormal Recycle: Hardware SLO flame bias range
333	Abnormal Recycle: Hardware SLO flame bias heat
334	Abnormal Recycle: Hardware SLO spark stuck
335	Abnormal Recycle: Hardware SLO spark changed
336	Abnormal Recycle: Hardware SLO static flame
337	Abnormal Recycle: Hardware SLO rod shorted
338	Abnormal Recycle: Hardware SLO AD linearity
339	Abnormal Recycle: Hardware SLO bias not set
340	Abnormal Recycle: Hardware SLO bias shorted

CODE	DESCRIPTION
341	Abnormal Recycle: Hardware SLO electronics
342	Abnormal Recycle: Hardware processor clock
343	Abnormal Recycle: Hardware AC phase
344	Abnormal Recycle: Hardware A2D mismatch
345	Abnormal Recycle: Hardware VSNSR A2D
346	Abnormal Recycle: Hardware 28V A2D
347	Abnormal Recycle: Hardware HFS IAS shorted
348	Abnormal Recycle: Hardware PII INTLK shorted
349	Abnormal Recycle: Hardware HFS LCI shorted
350	Abnormal Recycle: Hardware HFS LFS shorted
351	Abnormal Recycle: Invalid zero crossing
352	Abnormal Recycle: fault stack sensor
353	Abnormal Recycle: stack limit
354	Abnormal Recycle: delta T limit
355	Abnormal Recycle: fault outlet sensor
356	Abnormal Recycle: outlet high limit
357	Abnormal Recycle: fault DHW sensor
358	Abnormal Recycle: DHW high limit
359	Abnormal Recycle: fault inlet sensor
360	Abnormal Recycle: Check Parameters Failed
	Internal Errors
361	Internal error: No factory parameters were detected in control
362	Internal error: PID iteration frequency was invalid
363	Internal error: Demand-Rate interval time was invalid
364	Internal error: Factory calibration parameter for modulation was invalid
365	Internal error: CH PID P-scaler was invalid
366	Internal error: CH PID I-scaler was invalid
367	Internal error: CH PID D-scaler was invalid
368	Internal error: DHW PID P-scaler was invalid
369	Internal error: DHW PID I-scaler was invalid
370	Internal error: DHW PID D-scaler was invalid
371	Internal error: Lead Lag master PID P-scaler was invalid
372	Internal error: Lead Lag master PID I-scaler was invalid
373	Internal error: Lead Lag master PID D-scaler was invalid
374	Abnormal Recycle: Hardware flame bias high
375	Abnormal Recycle: Hardware flame bias low
376	Abnormal Recycle: Hardware flame bias delta high
377	Abnormal Recycle: Hardware flame bias delta low
378	Abnormal Recycle: Hardware flame bias dynamic high
379	Abnormal Recycle: Hardware flame bias dynamic low
380	Abnormal Recycle: Fan Speed Not Proven
381	Abnormal Recycle: Fan Speed Range Low

CODE	DESCRIPTION
382	Abnormal Recycle: Fan Speed Range High
383-450	RESERVED
	Circulator Errors
451	Circulator control was invalid
452	Circulator P-gain was invalid
453	Circulator I-gain was invalid
454	Circulator temperature was invalid
455	Circulator outlet temperature was invalid
456	Circulator inlet temperature was invalid
457	Circulator outdoor temperature was invalid
458	Circulator sensor choice was invalid
459	Circulator PID setpoint was invalid
	Debug Faults
460	LCI lost in run
461	Abnormal Recycle: Demand lost in run from application
462	Abnormal Recycle: Demand lost in run due to high limit
463	Abnormal Recycle: Demand lost in run due to no flame
464	LCI lost in Combustion Pressure Establishing Period
465	LCI lost in Combustion Pressure Stabilization Period
466	RESERVED
	Internal Data Faults
467	Internal error: EEPROM write was attempted before EEPROM was initialized
468	Internal error: EEPROM cycle count address was invalid
469	Internal error: EEPROM days count address was invalid
470	Internal error: EEPROM hours count address was invalid
471	Internal error: Lockout record EEPROM index was invalid
472	Internal error: Request to write PM status was invalid
473	Internal error: PM parameter address was invalid
474	Internal error: PM safety parameter address was invalid
475	Internal error: Invalid record in lockout history was removed
476	Internal error: EEPROM write buffer was full
477	Internal error: Data too large was not written to EEPROM
478	Internal error: Safety key bit 0 was incorrect
479	Internal error: Safety key bit 1 was incorrect
480	Internal error: Safety key bit 2 was incorrect
481	Internal error: Safety key bit 3 was incorrect

CODE	DESCRIPTION
482	Internal error: Safety key bit 4 was incorrect
483	Internal error: Safety key bit 5 was incorrect
484	Internal error: Safety key bit 6 was incorrect
485	Internal error: Safety key bit 7 was incorrect
486	Internal error: Safety key bit 8 was incorrect
487	Internal error: Safety key bit 9 was incorrect
488	Internal error: Safety key bit 10 was incorrect
489	Internal error: Safety key bit 11 was incorrect
490	Internal error: Safety key bit 12 was incorrect
491	Internal error: Safety key bit 13 was incorrect
492	Internal error: Safety key bit 14 was incorrect
493	Internal error: Safety key bit 15 was incorrect
494	Internal error: Safety relay timeout
495	Internal error: Safety relay commanded off
496	Internal error: Unknown safety error occurred
497	Internal error: Safety timer was corrupt
498	Internal error: Safety timer was expired
499	Internal error: Safety timings
500	Internal error: Safety shutdown
501	RESERVED
	MIX Errors
502	Mix setpoint was invalid
503	Mix time of day setpoint was invalid
504	Mix outdoor temperature was invalid
505	Mix ODR time of day setpoint was invalid
506	Mix ODR time of day setpoint exceeds normal setpoint
507	Mix ODR max outdoor temperature was invalid
508	Mix ODR min outdoor temperature was invalid
509	Mix ODR low water temperature was invalid
510	Mix ODR outdoor temperature range was invalid
511	Mix ODR water temperature range was invalid
512	Mix demand switch was invalid
513	Mix ON hysteresis was invalid
514	Mix OFF hysteresis was invalid
515	Mix ODR min water temperature was invalid
516	Mix hysteresis step time was invalid
517	Mix P-gain was invalid
518	Mix I-gain was invalid
519	Mix D-gain was invalid
520	Mix control was suspended due to fault
521	Mix S10 (J10-7) temperature was invalid
522	Mix outlet temperature was invalid
523	Mix inlet temperature was invalid
524	Mix S5 (J8-11) temperature was invalid
525	Mix modulation sensor type was invalid
526	Mix ODR min water temperature setpoint was invalid

CODE	DESCRIPTION
527	Mix circulator sensor was invalid
528	Mix flow control was invalid
529	Mix temperature was invalid
530	Mix sensor was invalid
531	Mix PID setpoint was invalid
532	STAT may not be a Mix demand source when Remote Stat is enabled
533-539	RESERVED
540	Delta T inlet/outlet enable was invalid
541	Delta T exchanger/outlet enable was invalid
542	Delta T inlet/exchanger enable was invalid
543	Delta T inlet/outlet degrees was out of range
544	Delta T exchanger/outlet degrees was out of range
545	Delta T inlet/exchanger degrees was out of range
546	Delta T response was invalid
547	Delta T inversion limit response was invalid
548	Delta T rate limit enable was invalid
549	Delta T exchanger/outlet wasn't allowed due to stack limit setting
550	Delta T inlet/outlet limit was exceeded
551	Delta T exchanger/outlet limit was exceeded
552	Delta T inlet/exchanger limit was exceeded
553	Inlet/outlet inversion occurred
554	Exchanger/outlet inversion occurred
555	Inlet/exchanger inversion occurred
556	Delta T exchanger/outlet wasn't allowed due to stack connector setting
557	Delta T inlet/exchanger wasn't allowed due to stack limit setting
558	Delta T inlet/exchanger wasn't allowed due to stack connector setting
559	Delta T delay was not configured for recycle response
	T Rise Errors
560	Outlet T-rise enable was invalid
561	Heat exchanger T-rise enable was invalid
562	T-rise degrees was out of range
563	T-rise response was invalid
564	Outlet T-rise limit was exceeded
565	Heat exchanger T-rise limit was exceeded
566	Heat exchanger T-rise wasn't allowed due to stack limit setting
567	Heat exchanger T-rise wasn't allowed due to stack connector setting
568	Outlet T-rise wasn't allowed due to outlet connector setting
569	T-rise delay was not configured for recycle response
	Heat Exchanger High Limit Errors
570	Heat exchanger high limit setpoint was out of range

CODE	DESCRIPTION
571	Heat exchanger high limit response was invalid
572	Heat exchanger high limit was exceeded
573	Heat exchanger high limit wasn't allowed due to stack limit setting
574	Heat exchanger high limit wasn't allowed due to stack connector setting
575	Heat exchanger high limit delay was not configured for recycle response
	Pump Errors
576	CH pump output was invalid
577	DHW pump output was invalid
578	Water Heater pump output was invalid
579	Auxiliary pump output was invalid
580	System pump output was invalid
581	Mix pump output was invalid
582-589	RESERVED
	DHW Plate Heat Exchanger Errors
590	DHW plate preheat setpoint was invalid
591	DHW plate preheat ON hysteresis was invalid
592	DHW plate preheat OFF hysteresis was invalid
593	Tap detect degrees was out of range
594	Tap detect ON hysteresis was invalid
595	Inlet - DHW tap stop degrees was out of range
596	Outlet - Inlet tap stop degrees was out of range
597	DHW tap detect on threshold was invalid
598	DHW plate preheat detect on threshold was invalid
599	DHW plate preheat detect off threshold was invalid

MAINTENANCE PROCEDURES

MAINTENANCE SCHEDULES

Yearly procedures for Service Technician:

- Check for reported problems.
- Check the interior; clean and vacuum if needed.
- Clean the condensate trap and fill with fresh water.
- Check for water/gas/flue/ condensate leaks.
- Ensure flue and air lines in good condition and sealed tight
- Check system water pressure/system piping/expansion tank
- Check control settings.
- Check spark igniter and flame sensors. Clear and clean any deposits.
- Check wiring and connections.
- Perform start-up checkout and performance verification.
- Flame inspection (stable, uniform)
- Flame signal (at least 10 microamps at high fire)
- Clean the heat exchanger if flue temperature is more than 54°F (30°C) above return water temperature.
- Test low water flow conditions.
- Clean the heat exchanger.
- Remove and clean burner using compressed air.

Maintenance by Owner:

Daily:

- Check water heater area .
- Check pressure/temperature gauge.

Monthly:

- Check vent piping.
- Check air intake piping (Direct Vent).
- Check air and vent termination screens.
- Check relief valve.
- Check condensate drain system.
- Check automatic air vents .

Every 6 months:

- Check water heater piping (gas and water) for leaks.
- Check and operate the pressure relief valve.

End of season months:

- Shut the water heater down (unless water heater used for domestic hot water)

The maintenance of the water heater must be performed to assure maximum water heater efficiency and reliability. Failure to service and maintain the water heater and system could result in equipment failure.

Make sure to turn off power to the water heater before any service operation on the water heater except as noted otherwise in this instruction manual. Failure to turn off electrical power could result in electrical shock, causing severe personal injury or death.

INSPECT WATER HEATER AREA

1. Verify that water heater area is free of any combustible materials, gasoline and other flammable vapors and liquids.
2. Verify that air intake area is free of any of the contaminants. If any of these are present in the water heater intake air vicinity, they must be removed. If they cannot be removed, reinstall the air and vent lines per this manual.

Inspect water heater interior:

1. Remove the front access cover and inspect the interior of the water heater.
2. Vacuum any sediment from inside the water heater and components. Remove any obstructions.

GENERAL MAINTENANCE

This is a pre-mix burner system. The flame is not supposed to be directly on the burner. The flame should be just above the burner deck approximately 1/8" and blue in color, see Figure 75.

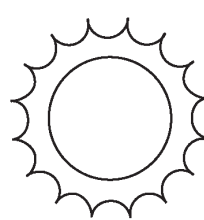

NORMAL BURNER FLAME

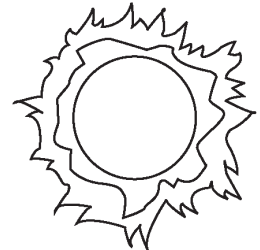

ABNORMAL BURNER FLAME

FIGURE 75. BURNER FLAMES

Visually check flame characteristics through the view port located on the top head of the water heater. Figure 75 shows the normal flame condition.

These water heaters are designed to give many years of efficient and satisfactory service when properly operated and maintained. To assure continued good performance, the following recommendations are made.

The area around the unit should be kept clean and free from lint and debris. Sweeping the floor around the water heater should be done carefully. This will reduce the dust and dirt which may enter the burner and heat exchanger, causing improper combustion and sooting.

MAIN BURNER

Check main burner every three months for proper flame characteristics. The main burner should display the following characteristics:

- Provide complete combustion of gas.
- Cause rapid ignition and carry over of flame across entire burner.
- Give reasonably quiet operation during initial ignition, operation and extinction.
- Cause no excessive lifting of flame from burner ports.

If the preceding burner characteristics are not evident, check for accumulation of lint or other foreign material that restricts or blocks the air openings to the burner or water heater. To check burners:

1. Shut off all gas and electricity to unit. Allow unit to cool.
2. Remove main burners from unit.
3. Check that burner ports are free of foreign matter.
4. Clean burner with vacuum cleaner. Do not distort burner ports.
5. Reinstall burners in unit. Ensure that all the screws on the burner flange are tightened securely so that the gasket will provide a good seal.
6. Also check for good flow of combustion and ventilating air to the unit.

After placing the water heater in operation, check the ignition system safety shut-off devices for proper operation. To accomplish this with the main burner operating, close the valve on the manifold. Within four seconds the main burners should extinguish. If this does not occur immediately, discontinue gas supply by closing main manual shut-off and call a qualified service technician to correct the situation. If the burners extinguish, then light water heater in accordance with lighting and operating instructions.

<p>⚠ WARNING</p> <p>Combustion Air</p> <p>The flow of combustion air to the water heater must not be obstructed.</p> <p>The water heater area must be kept clear and free from combustible materials, gasoline and other flammable vapors and liquids.</p>
--

Any safety devices including low water cutoffs used in conjunction with this water heater should receive periodic (every six months) inspection to assure proper operation. A low water cutoff device of the float type should be flushed every six months. Periodic checks, at least twice a year, should be made for water leaks.

More frequent inspections may be necessary depending on water conditions.

The water heater-mounted gas and electrical controls have been designed to give both dependable service and long life. However, malfunction can occur, as with any piece of equipment. It is therefore recommended that all components be checked periodically by a qualified service technician for proper operation.

BURNER MAINTENANCE

Qualified service agent should follow this procedure when the water heater's burner needs cleaning.

1. Turn off the electrical power to the water heater and close the main manual gas shutoff valve(s). Allow the water heater parts to cool before disassembly.
2. Loosen the flange and separate the gas train from the manifold assembly.
3. Separate the burner from the blower adapter by first removing the four (4) bolts and subsequently, the blower gaskets. The blower should be free to move at this point.
4. For Direct Vent units: It is necessary to loosen and slide the rubber coupling on the blower adaptor in order to move the blower.

5. Loosen the seven bolts on the blower adapter at the base and move the burner ground wire (Green) aside.
6. Lift the blower adapter and remove the manifold assembly up from the 6 studs located on the cover plate and remove the burner gasket.
7. Remove any loose foreign material such as dust or lint with a vacuum. Check all ports for blockage. Dislodge any foreign material causing blockage. Remove any soot or carbon deposits with a rag making sure to remove any lint left on the burner by vacuuming again.
8. Reverse the steps to reassemble the unit.
9. Restore electrical power and gas supply to the water heater.
 - Put the water heater back in operation by following the Lighting and Operating instructions in this manual.
 - Check for gas leaks and proper water heater and vent operation.

PRESSURE RELIEF VALVE

The pressure relief valve should be opened at least twice a year to check its working condition. This will aid in assuring proper pressure relief protection. Lift the lever at the top of the valve several times until the valve seats properly and operates freely.

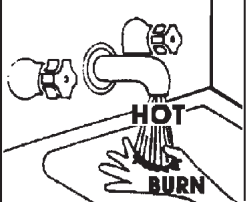
<p>⚠ DANGER</p>  <p>HOT BURN</p>	<ul style="list-style-type: none">• Burn hazard.• Hot water discharge.• Keep hands clear of drain valve discharge.
--	--

<p>⚠ WARNING</p> <p>Gas Supply</p> <p>Should overheating occur or the gas supply fail to shut off, turn off the manual gas control valve to the appliance.</p>
--

BLOWER COMPARTMENT

The blower compartment should be cleaned annually to remove any dirt and lint that may have accumulated in the compartment or on the blower and motor. Buildups of dirt and lint on the blower and motor can create excessive loads on the motor resulting in higher than normal operating temperatures and possible shortened service life.

AIR FILTER BOX

The air filter box should be cleaned every three months to remove any dust and debris that may have accumulated in the air filter or the filter housing. Buildups of dust on the air filter can block the air intake into the water heater. Air filter can be washed and cleaned with water.

CONDENSATE REMOVAL SYSTEM

Due to the highly efficient operation of this unit, condensate is formed during operation and must be removed by the condensate drain systems. Inspect the condensate drains and tubes at least once a month and insure they will allow the free flow of condensate at all times. The system must be inspected more frequently in cold weather if the drain system is located in an area, such as along the floor, where freezing temperatures are likely to occur. The condensate drain system must be protected against freezing. Contact a qualified service agent to inspect and correct the condition if freezing of the condensate lines is a problem.

The transparent drain lines and condensate drain on the bottom of the vent collector should be visually inspected at one month intervals for blockage, particularly in the areas of the loops in the lines which trap a small amount of condensate, and the exit point of the vent collector drain. Condensate in portions of the line other than the loop area indicates a blockage in the drain line. Flush the lines with air or water and clear or replace the blocked portions of the line as necessary. Note that areas of the drain line which include a sag or low spot in the line will also form a condensate trap which can be removed by levelling the tube and does not indicate a blocked system.

Inspect the metal vent drain and vent collector drain connectors at six month intervals. Remove the hoses from the connections, then check with a small wooden dowel or plastic rod passed up through the metal connection to insure the passage is clear, using caution to not bend or damage the connector. Call a qualified service agent to inspect and correct the problem if any obstructions are found in the connectors. Replace all hoses and clamps immediately after inspection and before starting the water heater in accordance with the Lighting and Operating Instructions. Do not operate the water heater unless all condensate drain lines are properly connected and working. When a means to neutralize condensate has been installed you must also follow operating, inspection and maintenance procedures specified by the manufacturer of the product. Inspect the installed device to insure that it does not cause condensate to remain in the water heater or vent for any reason.

VENTING MAINTENANCE

It is recommended that the intake and exhaust piping of the water heater be checked every 6 months for dust, condensate leakage, deterioration and carbon deposits.

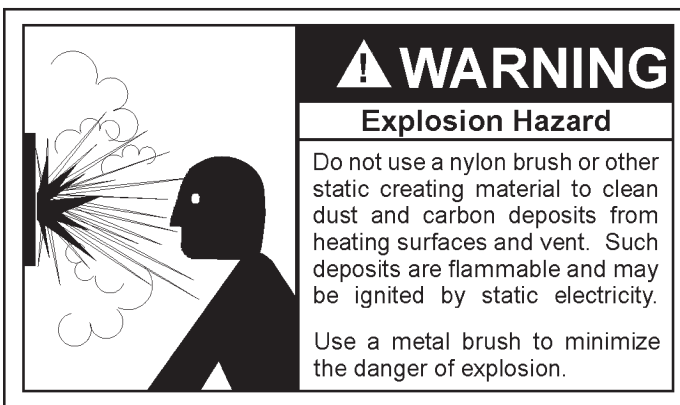

Qualified service agent should follow this procedure when the water heater's intake and exhaust piping need cleaning:

1. Turn off the electrical power, and manual gas shut-off.
 - Allow water heater parts to cool before disassembly.
2. Remove the vent pipe.
 - Check parts and chimney for obstructions and clean as necessary.
3. Remove burner from water heater and other metal parts as required to clean as necessary.
 - Refer to parts list for disassembly aid.
4. Clean and reinstall the parts removed in steps 2 and 3.
 - Be sure the vent pipe has a minimum upward pitch of 1/4" per foot (2 cm/m) of length and is sealed as necessary.
5. Restore electrical power and gas supply to water heater.
 - Check for gas leaks and proper water heater and vent operation.

HEAT EXCHANGER MAINTENANCE

1. Shut down the water heater:
 - Turn Off gas to the water heater.
 - Do not drain the water heater unless it will be exposed to freezing temperatures.
2. Ensure the water heater cools down to room temperature.
3. Remove the nuts securing the heat exchanger access cover to the heat exchanger and set aside.
4. Remove the heat exchanger access cover, burner, and gas train assembly.

NOTE: The water heater contains ceramic fiber materials. Failure to comply could result in severe personal injury.

5. Remove the condensate hose from the heat exchanger end. Connect a field supplied 3/4" diameter hose to a drain pan.
6. Use a vacuum cleaner to remove any deposits/ debris on the water heater heating surfaces. Do not use any solvent.
7. Brush the heat exchanger while dry using a nylon bristle brush. Re-vacuum the heat exchanger.
8. Finish cleaning using a clean cloth dampened with warm water. Rinse out debris with a low pressure water supply.
9. Allow the heat exchanger to dry completely.
10. Remove the rear refractory cover from the back of the combustion chamber of the heat exchanger and reassemble.
11. Close isolation valves on piping to isolate the water heater from system. Attach a hose to the water heater drain and flush water heater thoroughly with clean water by using purging valves to allow water to flow through the water make-up line to the water heater.
12. Replace the access cover and restore the water heater for operation.

HANDLING CERAMIC FIBER MATERIALS

Removal of combustion chamber lining:

The combustion chamber insulation in this water heater contains ceramic fiber material. Ceramic fibers can be converted to cristobalite in very high temperature applications. The International Agency for Research on Cancer (IARC) has concluded, "Crystalline silica in the form of quartz or cristobalite from occupational sources is carcinogenic to humans (Group 1)." Normal operating temperatures in this water heater are below the level to convert ceramic fibers to cristobalite.

The ceramic fiber material used in this water heater is an irritant; hence when handling or replacing the ceramic materials it is advisable that the installer follow these safety guidelines.

1. Avoid breathing dust and contact with skin and eyes.
 - Use NIOSH certified dust respirator (N95). This type of respirator is based on the OSHA requirements for cristobalite at the time this document was written. Other types of respirators may be needed depending on the job site conditions. Current NIOSH recommendations can be found on the NIOSH website at <http://www.cdc.gov/niosh/homepage.html>. NIOSH approved respirators, manufacturers, and phone numbers are also listed on this website.
 - Wear long-sleeved, loose fitting clothing, gloves, and eye protection.
2. Apply enough water to the combustion chamber lining to prevent airborne dust.
3. Remove the combustion chamber lining from the water heater and place it in a plastic bag for disposal.
4. Wash potentially contaminated clothes separately from other clothing. Rinse clothes washer thoroughly.

NIOSH stated First Aid:

- Eye: Irrigate immediately.
- Breathing: Fresh air.

REPLACEMENT PARTS

Replacement parts may be ordered through A. O. Smith dealers, authorized servicers or distributors. Refer to the Yellow Pages for where to call or contact (in United States) the **A. O. Smith Corporation, 500 Tennessee Waltz Parkway, Ashland City, TN 37015, 1-800-433-2545** or (in Canada) **A. O. Smith Enterprises Ltd., 599 Hill Street West, Fergus, ON N1M2X1, 1-888-479-2837**. When ordering parts be sure to state the quantity, part number and description of the item including the complete model and serial number as it appears on the product. Refer to the parts list for more information.

For Technical Assistance call A. O. Smith Technical Information Center at 1-800-527-1953.

PIPING DIAGRAMS

LEGEND

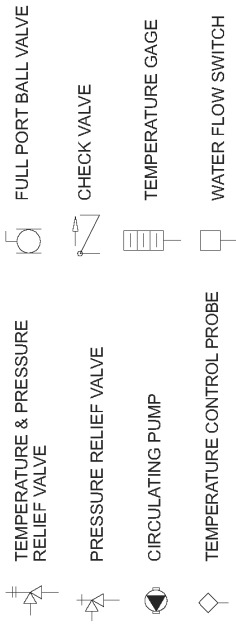

XP WATER HEATERS XWH (1000-3400) - ONE WATER HEATER/VERTICAL STORAGE TANK RECOVERY SYSTEM (ONE TEMPERATURE)

CAUTION: THIS DRAWING SHOWS SUGGESTED PIPING CONFIGURATION AND OTHER DEVICES; CHECK WITH LOCAL CODES AND ORDINANCES FOR ADDITIONAL REQUIREMENTS.

XP WATER HEATER MODEL (XWH)	WATER HEATER PIPING SIZE (INCH)
1000-1300	2"
1700	2-1/2"
2000	3"
2600	3"
3400	4"

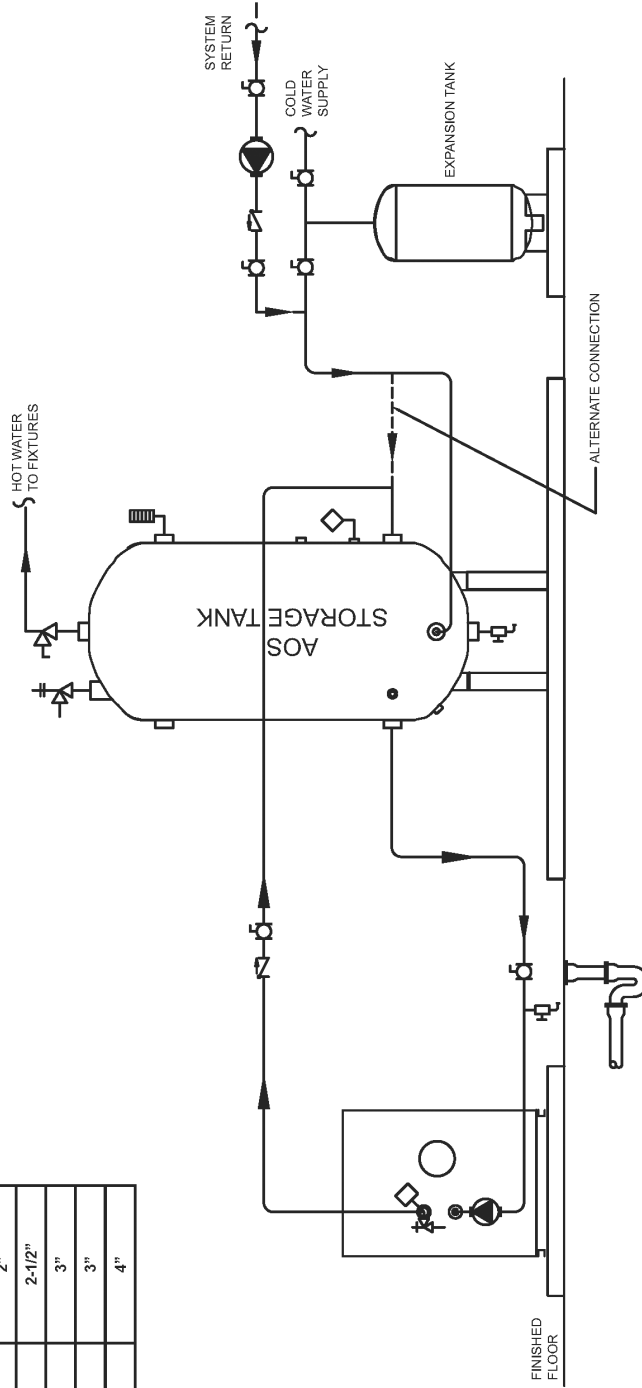

NOTES:

1. Preferred piping layout.
2. The temperature and pressure relief valve setting shall not exceed pressure rating of any component in the system.
3. Service valves are shown for servicing water heater. However, local codes shall govern their usage.
4. A. O. Smith piping method is based on the 50 equivalent feet of piping. Water heater placement shall be as close as practical to the storage tank. Applications in excess of these recommendations shall require a licensed engineer for design assistance.









FIGURE 76. HOT WATER SUPPLY WATER HEATER WITH VERTICAL TANK

XP WATER HEATERS XWH (1000-3400) - ONE WATER HEATER/HORIZONTAL STORAGE TANK RECOVERY SYSTEM (ONE TEMPERATURE)

CAUTION: THIS DRAWING SHOWS SUGGESTED PIPING CONFIGURATION AND OTHER DEVICES; CHECK WITH LOCAL CODES AND ORDINANCES FOR ADDITIONAL REQUIREMENTS.

XP WATER HEATER MODEL (XWH)	WATER HEATER PIPING SIZE (INCH)
1000-1300	2"
1700	2-1/2"
2000	3"
2600	3"
3400	4"

LEGEND

-  TEMPERATURE & PRESSURE RELIEF VALVE
-  PRESSURE RELIEF VALVE
-  CIRCULATING PUMP
-  TEMPERATURE CONTROL PROBE
-  DRAIN
-  FULL PORT BALL VALVE
-  CHECK VALVE
-  TEMPERATURE GAGE
-  WATER FLOW SWITCH

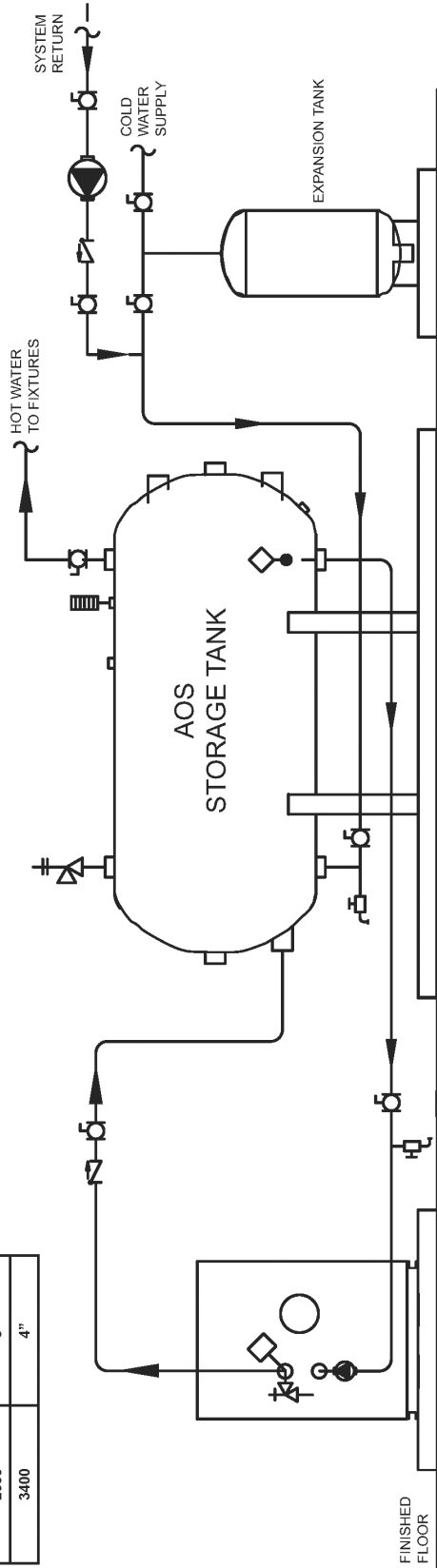

NOTES:

1. Preferred piping layout.
2. The temperature and pressure relief valve setting shall not exceed pressure rating of any component in the system.
3. Service valves are shown for servicing water heater. However, local codes shall govern their usage.
4. A. O. Smith piping method is based on the 50 equivalent feet of piping. Water heater placement shall be as close as practical to the storage tank. Applications in excess of these recommendations shall require a licensed engineer for design assistance.

FIGURE 77. HOT WATER SUPPLY WATER HEATER WITH HORIZONTAL TANK

NOTES

NOTES

LIMITED WARRANTY

A. O. Smith Corporation, the warrantor, extends the following LIMITED WARRANTY to the owner of this water heater:

1. If within FIVE years after initial installation of the water heater, a heat exchanger or gas burner should prove upon examination by the warrantor to be defective in material or workmanship, the warrantor, at his option will exchange or repair such part or portion.
 - a. This warranty is extended to the owner for all other parts or portion during the FIRST year following initial installation of this water heater.
 - b. The warranty on the repair or replacement of the part or portion will be limited to the unexpired term of the original warranty.

2. CONDITIONS AND EXCEPTIONS

This warranty should apply only when the water heater is installed in accordance with local plumbing and building codes, ordinances and regulations, the printed instructions provided with it and good industry practices. In addition, a pressure relief valve, certified by C.S.A. and approved by the American Society of Mechanical Engineers, must have been installed and potable water used for filling and make-up purposes.

- a. This warranty should apply only when the water heater is used:
 - (1) with outlet water temperatures not exceeding the maximum setting of its operative and/or high limit control;
 - (2) at water pressure not exceeding the working pressure shown on the water heater;
 - (3) when filled with potable water, free to circulate at all times and with the heat exchanger free of damaging scale deposits;
 - (4) in a non-corrosive and non-contaminated atmosphere;
 - (5) in the United States, its territories or possessions, and Canada;
 - (6) at a water velocity flow rate not exceeding or below the water heater's designed rates;
 - (7) indoor installation only.
- b. Any accident to the water heater, any misuse, abuse (including freezing) or alteration of it, any operation of it in a modified form, or any attempt to repair leaks in the heat exchanger will void this warranty.

3. SERVICE AND REPAIR EXPENSE

Under this limited warranty the warrantor will provide only a replacement part. The owner is responsible for all other costs. Such costs may include but are not limited to:

- a. Labor charges for service, removal, repair, or reinstallation of the component part;
- b. Shipping, delivery, handling, and administrative charges for forwarding the replacement part from the nearest distributor and returning the claimed defective part to such distributor.
- c. All cost necessary or incidental for any material and/or permits required for installation of the replacement.

4. LIMITATIONS ON IMPLIED WARRANTIES

Implied warranties, including any warranty of merchantability imposed on the sale of this water heater under state or provincial law are limited to one (1) year duration for the water heater or any of its parts. Some states and provinces do not allow limitations on how long an implied warranty lasts, so the above limitation may not apply to you.

5. CLAIM PROCEDURE

Any claim under this warranty should be initiated with the dealer who sold the water heater, or with any other dealer handling the warrantor's products. If this is not practicable, the owner should contact:

U.S. Customers

A. O. Smith Corporation
500 Tennessee Waltz Parkway
Ashland City, TN 37015
Telephone: 800-527-1953

Canadian Customers

A. O. Smith Enterprises Ltd.
599 Hill Street West
Fergus, ON N1M 2X1
Telephone: 1-888-479-2837

- a. The warrantor will only honor replacement with identical or similar parts thereof which are manufactured or distributed by the warrantor.
- b. Dealer replacements are made subject to in-warranty validation by warrantor.

6. DISCLAIMERS

NO OTHER EXPRESS WARRANTY HAS BEEN OR WILL BE MADE ON BEHALF OF THE WARRANTOR WITH RESPECT TO THE MERCHANTABILITY OF THE WATER HEATER OR THE INSTALLATION, OPERATION, REPAIR OR REPLACEMENT OF THE WATER HEATER. THE WARRANTOR Should NOT BE RESPONSIBLE FOR WATER DAMAGE, LOSS OF USE OF THE UNIT, INCONVENIENCE, LOSS OR DAMAGE TO PERSONAL PROPERTY, OR OTHER CONSEQUENTIAL DAMAGE. THE WARRANTOR Should NOT BE LIABLE BY VIRTUE OF THIS WARRANTY OR OTHERWISE FOR DAMAGE TO ANY PERSONS OR PROPERTY, WHETHER DIRECT OR INDIRECT, AND WHETHER ARISING IN CONTRACT OR TORT.

- a. Some states and provinces do not allow the exclusion or limitation of the incidental or consequential damage, so the above limitations or exclusions may not apply to you.
- b. This warranty gives you specific legal rights, and you may also have other rights which vary from state to state or province to province.

Fill in the following for your own reference. Keep it. Registration is not a condition of warranty. The model and serial number are found on the water heater's rating plate.

Owner _____

Installation Address _____

City and State _____ Zip Code _____

Date Installed _____ Model No. _____ Serial No. _____

Dealer's Name _____ Phone No. _____

Dealer's Address _____

FILL IN WARRANTY AND KEEP FOR FUTURE REFERENCE



25589 Highway 1, McBee, SC 29101
Technical Support: 800-527-1953 • Parts: 800-433-2545 • Fax: 800-644-9306
www.hotwater.com

Copyright © 2013 A. O. Smith Water Heater Company, All rights reserved.