

SOLAR WATER HEATING SYSTEMS

WITH DOUBLE WALL HEAT EXCHANGER
AND GAS BACKUP
FOR POTABLE WATER HEATING ONLY



Low Lead Content
Canadian Standards Association



Solar Collector
SRCC OG-100



Solar Water Heating System
SRCC OG-300





⚠ WARNING	
	<p>Read and understand this instruction manual and safety messages before installing, operating, or servicing this pump station. Failure to follow these instructions and safety messages could result in death or serious injury. This manual must remain with the pump station.</p>

ALL TECHNICAL AND WARRANTY QUESTIONS: SHOULD BE DIRECTED TO THE LOCAL DEALER FROM WHOM THE WATER HEATER WAS PURCHASED. IF YOU ARE UNSUCCESSFUL, PLEASE WRITE TO THE COMPANY LISTED ON THE RATING PLATE ON THE WATER HEATER.

**KEEP THIS MANUAL IN THE POCKET ON HEATER FOR FUTURE REFERENCE
WHENEVER MAINTENANCE ADJUSTMENT OR SERVICE IS REQUIRED.**

SAFE INSTALLATION, USE AND SERVICE

Your safety and the safety of others is extremely important in the installation, use, and servicing of this water heater. Many safety-related messages and instructions have been provided in this manual and on your own water heater to warn you and others of a potential injury hazard. Read and obey all safety messages and instructions throughout this manual. It is very important that the meaning of each safety message is understood by you and others who install, use, or service this water heater.

	<p>This is the safety alert symbol. It is used to alert you to potential personal injury hazards. Obey all safety messages that follow this symbol to avoid possible injury or death.</p>
	<p>DANGER indicates an imminently hazardous situation which, if not avoided, will result in injury or death.</p>
	<p>WARNING indicates a potentially hazardous situation which, if not avoided, could result in injury or death.</p>
	<p>CAUTION indicates a potentially hazardous situation which, if not avoided, could result in minor or moderate injury.</p>
	<p>CAUTION used without the safety alert symbol indicates a potentially hazardous situation which, if not avoided, could result in property damage.</p>

All safety messages will generally tell you about the type of hazard, what can happen if you do not follow the safety message, and how to avoid the risk of injury.

The California Safe Drinking Water and Toxic Enforcement Act requires the Governor of California to publish a list of substances known to the State of California to cause cancer, birth defects, or other reproductive harm, and requires businesses to warn of potential exposure to such substances.

WARNING: This product contains a chemical known to the State of California to cause cancer, birth defects, or other reproductive harm.

This appliance can cause low-level exposure to some of the substances listed in the act.

Hydrogen gas can be produced in a hot water system that has not been used for a long period of time (generally two weeks or more). Hydrogen gas is extremely flammable and can ignite when exposed to a spark or flame. To prevent the possibility of injury under these conditions, we recommend the hot water faucet be opened for several minutes at the kitchen sink before using any electrical appliance which is connected to the hot water system. If hydrogen is present, there will probably be an unusual sound such as air escaping through the faucet as water begins to flow. Do not smoke or have any open flame near the faucet at the time it is open.

IMPORTANT DEFINITIONS

- **Qualified Installer:** A qualified installer must have ability equivalent to a licensed tradesman in the fields of plumbing and electrical installation of these appliances. This would include a thorough understanding of the requirements of the National Electrical Code and applicable local electrical and plumbing codes (and tools necessary to confirm proper installation and operation of the water heater) as they relate to the installation of electric water heaters. The qualified installer must have a thorough understanding of the water heater Instruction Manual.
- **Service Agency:** A service agency also must have ability equivalent to a licensed tradesman in the fields of plumbing and electrical installation of these appliances. This would include a thorough understanding of the requirements of the National Electrical Code and applicable local electrical and plumbing codes (and tools necessary to confirm proper installation and operation of the water heater) as they relate to the installation of electric water heaters. The service agency must have a thorough understanding of the water heater Instruction Manual.

GENERAL SAFETY

⚠ WARNING



Read and understand this instruction manual and safety messages before installing, operating, or servicing this pump station. Failure to follow these instructions and safety messages could result in death or serious injury. This manual must remain with the pump station.

CAUTION

Improper installation, use and service may result in property damage.

- Do not operate water heater if flood damaged.
- Inspect the anode rods regularly, replace if damaged.
- Install in location with drainage.
- Fill tank with water before operation.
- Properly sized thermal expansion tanks are required on all closed water systems.

Refer to this manual for installation and service.

⚠ WARNING

Explosion Hazard

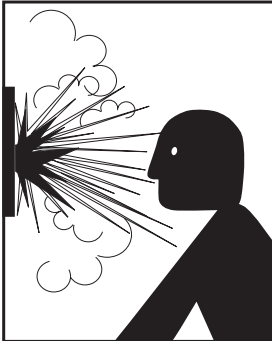

- Overheated water can cause water tank explosion.
- Properly sized temperature and pressure relief valve must be installed in the opening provided.

⚠ WARNING

Electrical Shock Hazard



- Before removing any access panels or servicing the water heater, make sure the electrical supply to the water heater is turned off.
- Failure to do this could result in death, serious bodily injury, or property damage.

⚠ DANGER

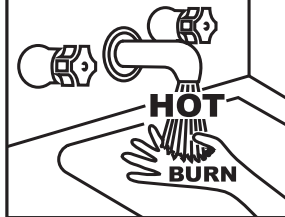

Water temperature over 125°F (52°C) can cause severe burns instantly resulting in severe injury or death.

Children, the elderly and the physically or mentally disabled are at highest risk for scald injury.

Feel water before bathing or showering.

Temperature limiting devices such as mixing valves must be installed when required by codes and to ensure safe temperatures at fixtures.

⚠ WARNING

Fire Hazard / Electric Shock Hazard



- DO NOT USE THIS PUMP STATION WITH ANY VOLTAGE OTHER THAN SHOWN ON THE MODEL RATING PLATE.
- FAILURE TO USE THE CORRECT VOLTAGE SHOWN ON THE MODEL RATING PLATE COULD RESULT IN DEATH, SERIOUS BODILY INJURY, OR PROPERTY DAMAGE.



INTRODUCTION

Thank You for purchasing this water heating system. Properly installed and maintained, it should give you years of trouble free service.

Abbreviations Found In This Instruction Manual:

- ANSI - American National Standards Institute
- ASME - American Society of Mechanical Engineers
- CSA - Canadian Standards Association
- NEC - National Electrical Code
- NFPA - National Fire Protection Association
- UL - Underwriters Laboratories Inc.
- SRCC - Solar Rating and Certification Corp.

SYSTEM DESCRIPTION

This Solar Water Heating System consists of four main parts — the solar collectors, the solar pump station, the solar storage tank, and the plumbing for the heat transfer fluid.

The solar pump station uses a pump to circulate a heat-transfer fluid through the “collector loop”. This collector loop includes the solar collectors, the fluid lines or “line-set” and a heat exchanger. The collector loop is a “closed loop”, meaning there is no contact of the heat transfer fluid with your potable water or with the atmosphere. The collector loop contains only a small volume of heat-transfer fluid which is non-toxic and freeze-protected to -30°F (Freeze tolerance limits are based upon an assumed set of environmental conditions). Though freeze protection may not be necessary in all areas, the heat-transfer fluid also contains corrosion inhibitors which protect the system components, has an elevated boiling point, and is suitable throughout North America.

When exposed to sunlight, the solar collectors get hot. As the heat-transfer fluid passes through the collectors, it absorbs the heat and then travels down the line-set to the tank. The hot fluid passes through the heat exchanger and heat is transferred to the potable water. After giving up its heat to the potable water, the cool heat-transfer fluid is pumped back to the solar collectors to be heated again. Hot potable water is stored in the solar storage tank.

The auxiliary or back-up electric-heating guarantees hot water even under poor solar conditions (at night or when very cloudy). The minimum acceptable temperature set-point is specified in local plumbing codes.

You can save the most money on your water-heating bills by using the backup heater on your system as little as possible. If the sun shines brightly between 10 AM and 3 PM, enough heat will normally be generated to keep the water hot throughout the rest of the day and night.

However, on days when the sky is cloudy or when large quantities of hot water are being used, we recommend leaving the backup heater turned on and set to 120° F to provide adequate hot water.

PREPARING FOR THE INSTALLATION

1. Read the “General Safety” section of this manual first and then the entire manual carefully. If you don't follow the safety rules, the water heater will not operate properly. It could cause DEATH, SERIOUS BODILY INJURY, AND/OR PROPERTY DAMAGE.
2. This manual contains instructions for the installation, operation, and maintenance of the solar water heater. It also contains warnings throughout the manual that you must read and understand. All warnings and all instructions are essential to the proper operation of the water heater and your safety. **READ THE ENTIRE MANUAL BEFORE ATTEMPTING TO INSTALL OR OPERATE THE WATER HEATER.**
3. The installation must conform with these instructions and the local code authority having jurisdiction and the requirements of the power company. In the absence of local code requirements follow NFPA-70, the National Electrical Code (current edition), which may be ordered from: National Fire Protection Association, 1 Batterymarch Park, Quincy, MA 02169.
4. If after reading this manual you have any questions or do not understand any portion of the instructions, call the local utility or the manufacturer whose name appears on the rating plate.
5. Carefully plan your intended placement of the water heater and collectors. **INSTALLATION OR SERVICE OF THIS WATER HEATER REQUIRES ABILITY EQUIVALENT TO THAT OF A LICENSED TRADESMAN IN THE FIELD INVOLVED. PLUMBING AND ELECTRICAL WORK ARE REQUIRED.**
6. Examine the location to ensure the water heater complies with the “Facts to Consider About the Location” section in this manual.
7. For California installation this water heater must be braced, anchored, or strapped to avoid falling or moving during an earthquake. See instructions for correct installation procedures. Instructions may be obtained from California Office of the State Architect, 400 P Street, Sacramento, CA 95814.
8. Massachusetts Code requires this water heater to be installed in accordance with Massachusetts 248-CMR 2.00: State Plumbing Code and 248-CMR 5.00.
9. The solar energy system described by this manual, when properly installed and maintained, meets the OG-100 and OG-300 standards established by the SRCC. This certification does not imply endorsement or warranty of this product by SRCC.

TABLE OF CONTENTS

SAFE INSTALLATION, USE AND SERVICE.....	2	Collector Piping Detail	21
Important Definitions.....	2	Sensor Mounting at Collector	21
GENERAL SAFETY.....	3	Piping through the Roof.....	21
INTRODUCTION.....	4	Pipe Insulation.....	21
System Description.....	4	PUMP STATION INSTALLATION.....	22
Preparing for the Installation.....	4	Pump Station.....	22
TABLE OF CONTENTS.....	5	Safety instructions	22
SYSTEM DIAGRAM / TYPICAL INSTALLATION	6	SOLEX Pump Station Components.....	22
SYSTEM COMPONENT PARTS.....	7	Safety Equipment	23
STORAGE TANK INSTALLATION.....	7	Wall mounting the solar pump station.....	23
Local Codes.....	7	Plumbing configuration.....	24
Temperature-Pressure Relief Valve.....	7	Function.....	25
Closed System / thermal expansion.....	8	Flowmeter.....	25
Locating the Solar Water Heater	8	Start-Up & Operation - Solar Pump Station.....	25
Water Piping.....	9	Leak Detection.....	25
Mixing Valves.....	9	Flushing.....	25
Installation in Residential Garages.....	9	Filling the Storage Tank Loop.....	26
Venting Installation	10	Preparation of the Heat Transfer Fluid	26
Filling the Solar Water Heater with Water.....	10	Filling the Solar Loop.....	26
Condensate Drain.....	10	Draining the Solar Loop.....	27
Gas Supply.....	10	PUMP STATION CONTROL INSTRUCTIONS.....	28
Electrical Wiring.....	10	Control Instructions.....	28
Power Supply	10	System Description.....	28
Thermostat	11	Operation and Function	29
Polarity Sensitive.....	11	TROUBLESHOOTING	36
Temperature Regulation.....	11	SYSTEM MAINTENANCE.....	39
Temperature Settings	11	System Checkpoint.....	39
Temperature Adjustment.....	11	Heat Transfer Fluid (HTF) Quality	39
High Temperature Limit Control (ECO).....	12	Piping and External Insulation	39
Tank Sensor.....	12	Wiring and Connections	39
Draining and Flushing.....	12	Fluid Leaks	39
Powered Anode Rods.....	13	Solar Panel Clarity	39
SOLAR COLLECTOR INSTALLATION	14	Expansion Tank	39
Collector Location.....	14	Vacation.....	39
General considerations.....	14	Emergency Shutdown	39
Collector Orientation.....	14	REPAIR PARTS.....	40
Spanner Mounting	16	Repair Parts Schedule.....	40
Attaching collector to mounting brackets.....	19	Dowfrost Heat Transfer Fluid Properties	41
Collector Piping	20	WARRANTY/MODELS/SOLAR RATING.....	INSERT SHEET

SYSTEM DIAGRAM / TYPICAL INSTALLATION

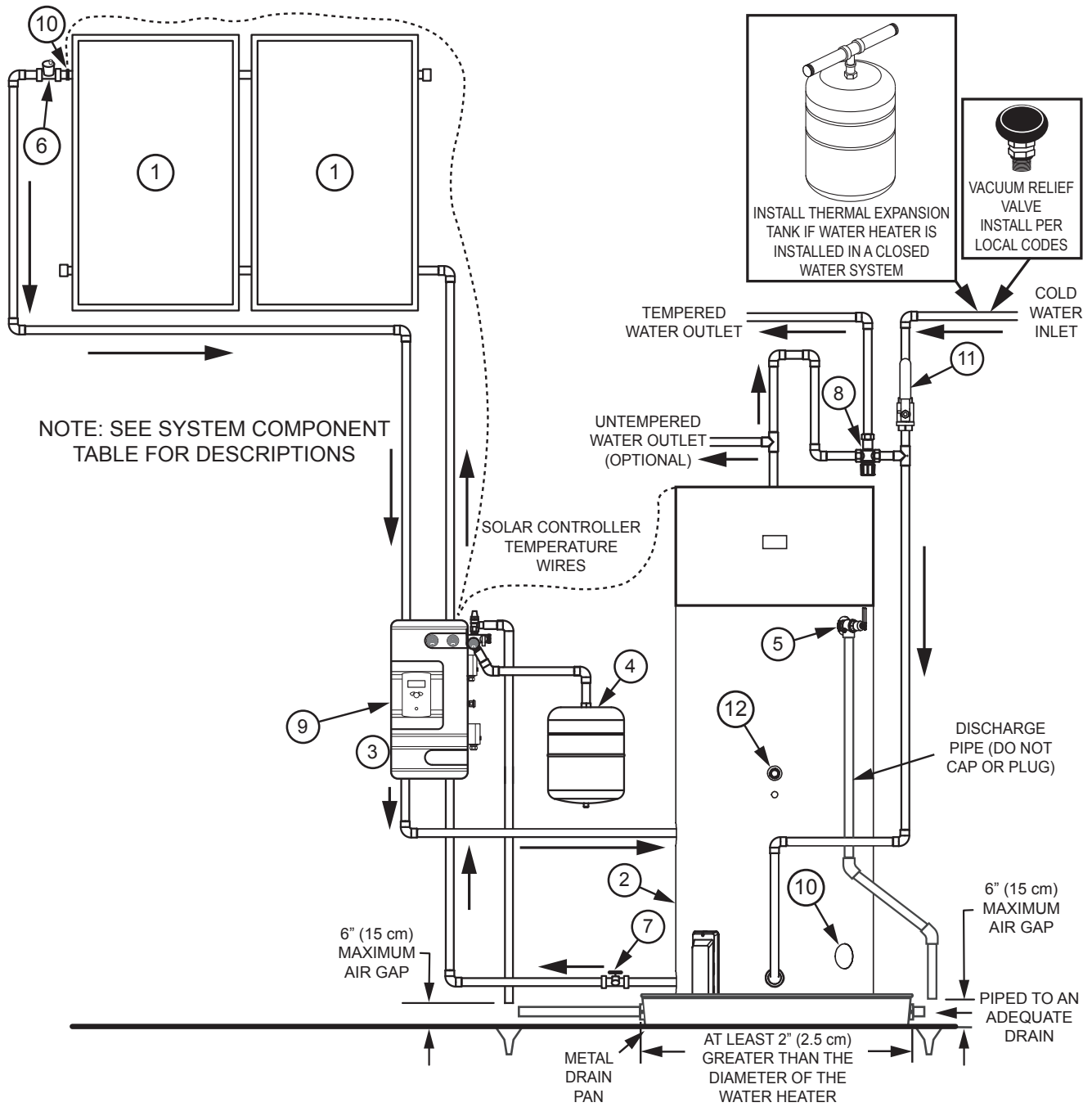

INSTALL VACUUM RELIEF IN COLD WATER INLET LINE AS REQUIRED BY LOCAL CODES.

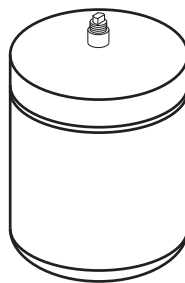

INSTALL THERMAL EXPANSION TANK OR DEVICE IF WATER HEATER IS INSTALLED IN A CLOSED WATER SYSTEM.

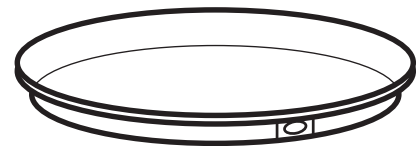

INSTALL SUITABLE METAL DRAIN PANS UNDER HEATERS TO PREVENT DAMAGE DUE TO LEAKAGE. REFER TO WATER HEATER LOCATION, SEE "LOCATING THE SOLAR WATER HEATER" ON PAGE 8.

Figure 1.

SYSTEM COMPONENT PARTS

ITEM	COMPONENT	FUNCTION
1	SOLAR COLLECTOR	Absorbs the sun's heat energy and transfers this to the heat transfer fluid circulating through the collector.
2	SOLAR STORAGE TANK	Stores potable water heated by solar generated heat or installed gas back-up.
3	HEAT EXCHANGER (Not Shown)	Transfers the heat from the collector loop to the potable water in the solar storage tank.
4	EXPANSION TANK	Allows for the expansion and contraction of the heat transfer fluid as it heat and cools.
5	TEMPERATURE and PRESURE RELIEF VALVE	Required by plumbing code to automatically open and dump water if the storage tank exceeds 150 PSI of pressure or 210° F in temperature.
6	AIR VENT	Purges air from the collector loop fluid during the installation.
7	DRAIN VALVE	Used to drain the heat transfer fluid from the collector loop.
8	MIXING VALVE (REQUIRED)	Used to temper hot water from the solar storage tank with cold inlet water to maintain appropriate temperature hot water delivered from the system.
9	SOLAR PUMP STATION	Controls the flow of heat transfer fluid from the collectors to the tank/ heat exchanger. For a detailed description of the solar pump station see the pump station installation section.
10	SOLAR TANK/COLLECTOR TEMPERATURE SENSORS	Tank and collector sensor work together to turn the circulating pump(s) on and off at preset temperature differentials.
11	COLD WATER CUT-OFF VALVE	Isolates the tank from incoming water supply.
12	LOWER TANK TEMPERATURE PROBE	1 of 2 temperature probes. The water heater's direct control system monitors this probe to detect water temperature in the lower portion of the storage tank.

Table 1.

STORAGE TANK INSTALLATION

Refer to the installation manual supplied with the Solar Storage Tank for more detailed instructions concerning its installation. This section is only meant to provide a brief overview regarding its installation with the solar system.

LOCAL CODES

The installation of this solar water heater must be in accordance with these instructions and all applicable local codes and electric utility requirements. In the absence of local codes, install in accordance with the latest editions of the National Fuel Gas Code, ANSI Z223.1/NFPA 54, and the National Electric Code NFPA 70 or CAN/CSA-B149.1.

TEMPERATURE-PRESSURE RELIEF VALVE

For protection against excessive pressures and temperatures in this water heater, install temperature-pressure protective equipment required by local codes, but not less than a combination temperature-pressure relief valve certified by a nationally recognized testing laboratory that maintains periodic inspection of production of listed equipment or materials, as meeting the requirements for Relief Valves for Hot Water Supply Systems, the latest edition of ANSI Z21.22. This valve must be marked with a maximum set pressure not to exceed the marked hydrostatic working pressure of the water heater (150 PSI).

Install the temperature-pressure relief valve directly into the

fitting of the water heater. Position the valve downward and provide a discharge pipe that must terminate a maximum of six inches above a floor drain or external to the building. In cold climates, it is recommended that the discharge pipe be terminated at an adequate drain inside the building. Be certain that no contact is made with any live electrical part. The discharge opening must not be blocked or reduced in size under any circumstances. Excessive length, over 15 feet, or use of more than two elbows can cause restriction and reduce the discharge capacity of the valve.

No valve or other obstruction is to be placed between the temperature-pressure relief valve and the tank. Do not connect tubing directly to discharge drain unless a 6" air gap is provided. To prevent bodily injury, hazard to life or damage to property, the temperature-pressure relief valve must be allowed to discharge water in quantities should circumstances demand. If the discharge pipe is not connected to a drain or other suitable means, the water flow may cause property damage.

The Discharge Pipe:

- Shall not be smaller in size than the outlet pipe size of the temperature-pressure relief valve, or have any reducing couplings or other restrictions.
- Shall not be plugged or blocked.
- Shall be of material listed for hot water distribution.
- Shall be installed so as to allow complete drainage of

both the temperature-pressure relief valve, and the discharge pipe.

- Must terminate a maximum of six inches above a floor drain or external to the building. In cold climates, it is recommended that the discharge pipe be terminated at an adequate drain inside the building.
- Shall not have any valve between the relief valve and tank.

When installing the temperature-pressure relief valve, use two or three turns of Teflon® tape or other suitable thread sealer around the threaded end of the valve.

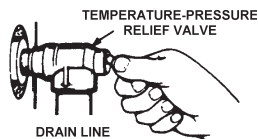

Figure 2.

The temperature-pressure relief valve should be manually opened once a year. Caution should be taken to ensure that (1) no one is in front of or around the outlet of the temperature-pressure relief valve discharge line, and (2) the water manually discharged will not cause any bodily injury or property damage because the water may be extremely hot.

If after manually operating the valve, it fails to completely reset and continues to release water, immediately close the cold water inlet to the water heater, follow the draining instructions, and replace the temperature-pressure relief valve with a new one.

If the temperature-pressure relief valve on the water heater weeps this may be due to thermal expansion. The water supply serving this solar water heater may have a check valve installed. Contact the water supplier or local plumbing contractor on how to control this situation. Do not plug the temperature-pressure relief valve.

CLOSED SYSTEM / THERMAL EXPANSION

As water is heated, it expands (thermal expansion). In a closed system, the volume of water will grow. As the volume of water grows, there will be a corresponding increase in water pressure due to thermal expansion. Thermal expansion can cause premature tank failure (leakage). This type of failure is not covered under the limited warranty. Thermal expansion can also cause intermittent temperature-pressure relief valve operation: water discharged from the valve due to excessive pressure build up. The temperature-pressure relief valve is not intended for the constant relief of thermal expansion. This condition is not covered under the limited warranty.

A properly-sized thermal expansion tank in accordance with ASHRAE recommendations should be installed on all closed systems to control the harmful effects of thermal expansion. Contact a plumbing service agency or your retail supplier regarding the installation of a thermal expansion tank.

LOCATING THE SOLAR WATER HEATER

If you have a choice of where to install the solar water heater, these ideas may help you decide.

1. Put the solar water heater indoors as close as possible to where you use the most hot water. This water heater is not intended for outdoor installation.
2. It is handy to have a floor drain, tub or sink nearby. That will make it easy to drain water from the water heater. It is also a good place to end the drain line of the temperature-pressure relief (T & P) valve.
3. The solar water heater or the pipes and the connections may, in time, leak. Put the solar water heater in a place where a water leak will not damage anything.
4. The solar water heater must not be located in an area where it will be subjected to freezing temperatures.
5. Make sure that you are able to reach the drain valve and all access panels when the water heater is in place. This will make it easy to service the water heater.
6. The water heater must be level before you begin the piping.
7. Locate the solar water heater close to a 120 VAC power supply.
8. Locate the solar water heater where an adequate supply of fresh air for combustion and ventilation can be obtained.
9. Locate the solar water heater where the vent and air intake piping, when installed, will remain within the maximum equivalent lengths allowed.
10. Do not locate the solar water heater where noise (such as the Combustion Blower) during normal operation will objectionable in adjacent areas.
11. Do not locate the solar water heater where the subsequent installation of the vent (exhaust) or intake air terminations would be objectionable due to noise at the termination(s). This includes locations close to or across from windows and doors.
12. Combustible materials used in solar equipment and adjacent structures shall not be exposed to an elevated temperature that could cause ignition.

WATER HEATERS EVENTUALLY LEAK. The installation of the water heater must be accomplished in such a manner that if the tank or any connections should leak, the flow of water will not cause damage to the area adjoining the water heater or to lower floors of the structure. When such locations can't be avoided, a suitable metal drain pan should be installed under the water heater. Such a pan should be no greater than 1 1/2 inches deep, have a minimum length and width of at least two inches greater than the heater dimensions and must be piped to an adequate drain.

This solar water heater, as all water heaters, will eventually leak. Do not install without adequate drainage provisions where water flow will cause damage. Note: normal condensation from a solar water heater may appear to be a leaking tank.

WATER PIPING

This solar water heater is design certified to be used with a potable water system. When connecting water piping with solder joints use only lead free solder.

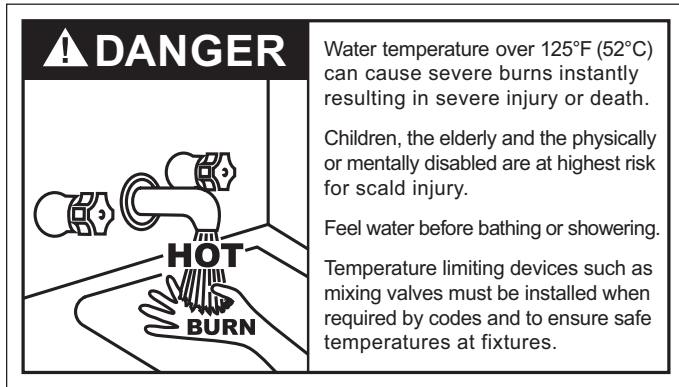

The indirect coil in this unit is a single wall and may only be used in a closed loop - fill only with a mixture of propylene glycol containing corrosion inhibitors (such as Dowfrost™) (50% by volume maximum) and distilled or de-mineralized water. Never fill with a toxic liquid. Use of any heat transfer fluid other than that specified or failure to operate the heat exchanger in a closed loop will void the warranty, and may result in poor performance, equipment damage, or risk to health and safety.

No other fluids shall be used that would change the original classification of this system. Unauthorized alterations to this system could result in a hazardous health condition.

This solar water heater shall not be connected to any heating systems or component(s) previously used with a non-potable water heating appliance.

If this solar water heater is also used for space heating applications, all piping and components connected to the solar water heater shall be suitable for use with potable water.

This appliance has been design certified as a solar water heater complying with the latest editions of the American National Standard ANSI Z21.10.3 and CSA Standard CSA 4.3.

Toxic chemicals such as used for treatment of boilers or non-potable water heating appliances shall never be introduced into a potable water space heating system.

MIXING VALVES

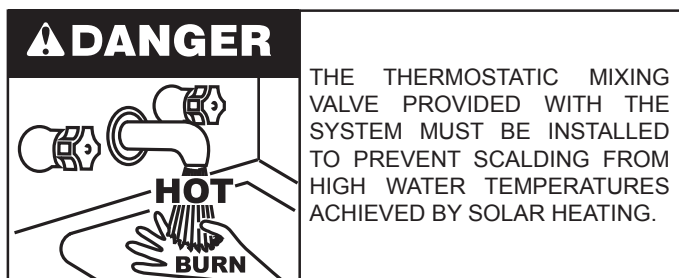

A mixing valve is supplied with this solar system. Water temperature above 120°F(49°C) can cause serious injury. The mixing valve should be installed and adjusted by a licensed contractor in accordance with local codes

and ordinances. Follow mixing valve manufacturer's instructions for installation and use of the valves.

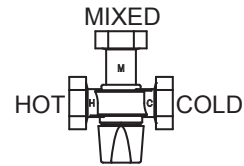

Figure 3.

The solar water heater will work better if you keep the hot water runs short. You will also get hot water faster and with less heat loss.

The illustration shows the correct valves and fittings that you will need to install the solar water heater. Threaded (1-1/2 NPT) water connections are supplied through the tank. The thermostatic mixing valve provided with the system has 1" sweat (solder) connections.

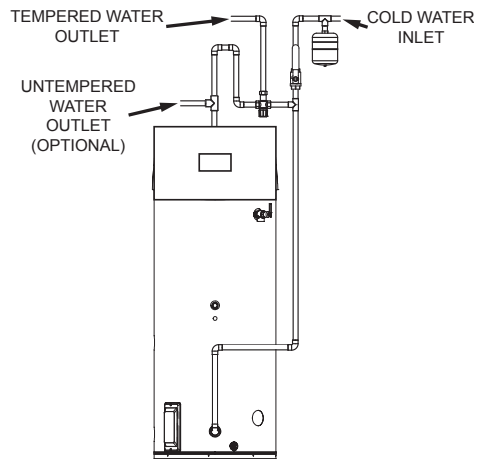

Figure 4.

1. Buy the fittings that you need to connect the pipes. Remember that you have to connect both the hot and cold water pipes.
2. Apply a light covering of pipe joint compound to each outside thread before making connection.
3. Connect the cold water supply pipe to the cold water inlet of your solar water heater as follows:
 - The cold water supply connection is located on the lower front of the solar water heater and the hot water outlet connection is located on the top cover.
 - The cold water supply line must have a shut-off valve and union. See Figure 4.

Operating an empty or partially filled solar water heater will result in damage to the tank.

If a solar water heater is installed in a closed water system; such as one having a back flow preventer, check valve or water meter with check valve in the cold water supply line, means such as an expansion tank shall be provided to control thermal expansion. Contact the water supplier or local plumbing contractor on how to control this situation.

INSTALLATION IN RESIDENTIAL GARAGES

The solar water heater must be located and/or protected so it is not subject to physical damage by a moving vehicle.

VENTING INSTALLATION

⚠ WARNING

Breathing Hazard - Carbon Monoxide Gas

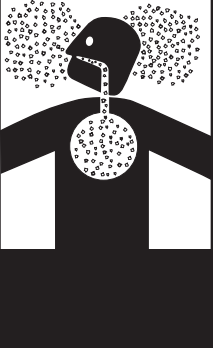

- Install vent system in accordance with codes.
- Do not operate water heater if flood damaged.
- Special consideration must be taken with installations above 10,000 feet (3,048 m) refer to high altitude section of this manual.
- Do not operate if soot buildup.
- Do not obstruct water heater air intake with insulating jacket or blanket.
- Do not place chemical vapor emitting products near water heater.
- Gas and carbon monoxide detectors are available.
- Never operate the heater unless it is vented to the outdoors and has adequate air supply to avoid risks of improper operation, fire, explosion or asphyxiation.
- Analyze the entire vent system to make sure that condensate will not become trapped in a section of vent pipe and therefore reduce the open cross sectional area of the vent.

**Breathing carbon monoxide can cause brain damage or death.
Always read and understand the instruction manual.**

Never operate the solar water heater unless it is vented to the outdoors. For safe operation an adequate supply of fresh uncontaminated air for combustion and ventilation must be provided

Refer to the “Air Requirements” and “Venting Installation” sections of the solar water heater installation manual for the proper air and venting requirements of the solar water heaters covered by this manual.

FILLING THE SOLAR WATER HEATER WITH WATER

Before filling the solar water heater with water, the pump station storage tank loop must be connected to the water heater. See the “Filling” and “Filling The Storage Tank Loop” sections of the manual. Plug the solar storage tank solar loop connections if they are not being used in your application.

1. Close the solar water heater drain valve. The drain valve is on the lower front of the solar water heater.
2. Open the cold water supply to the solar water heater. **NOTE: THIS VALVE MUST BE LEFT OPEN WHEN THE SOLAR WATER HEATER IS IN USE.**
3. Fill the solar water heater until a constant flow of water runs out an opened hot water faucet. This will let out air in the solar water heater and the piping. Close the faucet after all air has been purged and the water comes out with constant flow.
4. Check all the new water piping for leaks. Fix as needed.

CONDENSATE DRAIN

The solar water heaters covered in this manual are condensing appliances and require a building drain to be

located in close proximity to allow the condensate to drain freely. Installation must conform with these instructions and local building codes. Ensure the condensate drain is properly connected to the exhaust elbow on the water heater and draining freely to a suitable floor drain. Refer to the “Condensate Drain Installation” sections of the solar water heater installation manual.

GAS SUPPLY

Contact your local gas utility company to ensure that adequate gas service is available and to review applicable installation codes for your area.

⚠ WARNING

Fire and Explosion Hazard



- Do not use water heater with any gas other than the gas shown on the rating label.
- Excessive gas pressure to gas valve can cause serious injury or death.
- Turn off gas lines during installation.
- Contact a qualified installer or service agency for installation and service.

Make sure the gas supplied is the same type listed on the solar water heater’s rating label.

The solar water heaters covered in this manual are not intended for operation at higher than 10.5” W. C. (2.62 kPa) for natural gas and 14.0” W. C. (3.49 kPa) for propane gas supply pressure. Exposure to higher gas supply pressures may cause damage to the gas controls which could result in fire or explosion.

Refer to the Supply Gas Line and Installation sections of the installation manual supplied with the solar water heater for more details on the proper installation, sizing, and operational requirements of the supply gas.

ELECTRICAL WIRING

All electrical work must be installed in accordance with the National Electrical Code, ANSI/NFPA 70 or the Canadian Electrical Code, CSA C22.1 and local requirements.

When installed, the solar water heater must be electrically grounded in accordance with local codes or, in the absence of local codes, with the National Electrical Code, ANSI/NFPA 70 or the Canadian Electrical Code, CSA C22.1.

If any of the original wire as supplied with the water heater must be replaced, it must be replaced with 105°C rated wiring or its equivalent, except in the burner housing. In this case use 200°C rated wire.

POWER SUPPLY

The solar water heater covered in this manual requires a 120VAC, single phase, 60Hz, 15 amp power supply and

must also be electrically grounded in accordance with local codes or, in the absence of local codes, with the National Electrical Code, ANSI/NFPA 70 or the Canadian Electrical Code, CSA C22.1.

THERMOSTAT

Each thermostat is factory preset at 120°F to reduce the risk of scald injury. This setting has proven by experience to be most satisfactory from the standpoint of operational costs and household needs.

Solar water heaters installed in Florida require the thermostat(s) to be set at 125°F. If you wish to adjust the settings, see the “Temperature Adjustment” section of this installation manual on page 11.

POLARITY SENSITIVE

The solar water heater’s control system is polarity sensitive and will lock out and disable the gas heating operation if the polarity of the power supply is reversed. The control system will display the “AC Reversed” Fault message on the LCD. The 120 VAC hot wire from the power supply must connect to the black wire in the solar water heater’s junction box and 120 VAC neutral wire must connect to the white wire in the junction box for correct polarity.

NOTE: Do not apply power to the solar water heater before installation is complete and the solar water heater is filled with water.

TEMPERATURE REGULATION

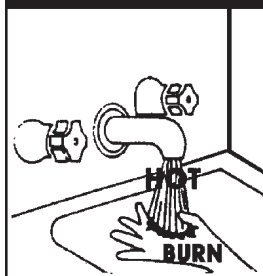

⚠ DANGER Untempered hot water can cause severe burns instantly resulting in severe injury or death.

Children, elderly, and the physically or mentally disabled are at highest risk for scald injury.

Feel water before bathing or showering.

Temperature limiting valves are available.

HOTTER WATER CAN SCALD: Solar water heaters are intended to produce hot water. Water heated to a temperature which will satisfy clothes washing, dish washing, and other sanitizing needs can cause scalds resulting in serious personal injury and/or death. Some people are more likely to be permanently injured by hot water than others. These include the elderly, children, the infirmed, or physically handicapped. If anyone using hot water in your home fits into one of these groups or if there is a local code or state law requiring a certain temperature water at the hot water tap, then you must take special precautions. Please see Figure 7 and Table 2 for information regarding thermostat settings. In addition to using the lowest possible temperature setting that satisfies your hot water needs, some type of mixing device, such as a mixing valve should be used at the hot water taps used by these people or at the solar water heater. Mixing

valves are available at plumbing supply or hardware stores. Follow manufacturers instructions for installation of the valves. Before changing the factory setting of the thermostat, read the Temperature Adjustment section.

KEEPING THE THERMOSTAT SETTING AT 120°F WILL REDUCE THE RISK OF SCALDS. Never allow small children to use a hot water tap, or to draw their own bath water. Never leave a child or handicapped person unattended in a bathtub or shower.

TEMPERATURE SETTINGS

The thermostat is factory set at its lowest position which approximates 120°F and is adjustable if a different water temperature is desired. For best system savings this temperature should not be changed. Read all warnings in this manual and on the solar water heater before proceeding.

Water Temperature °F	Time for 1st Degree Burn (Less Severe Burns)	Time for Permanent Burns 2nd & 3rd Degree (Most Severe Burns)
110	(normal shower temp.)	
116	(pain threshold)	
116	35 minutes	45 minutes
122	1 minute	5 minutes
131	5 seconds	25 seconds
140	2 seconds	5 seconds
149	1 second	2 seconds
154	instantaneous	1 second
(U.S. Government Memorandum, C.P.S.C., Peter L. Armstrong, Sept. 15, 1978)		

Table 2.

TEMPERATURE ADJUSTMENT

The solar water heater covered in this manual is equipped with an electronic control system to regulate the water temperature. The “Operating Set Point” is adjusted to regulate the water temperature inside the storage tank. This is an adjustable user setting in the control system’s “Temperatures” Menu.: This and all control system menus are accessed through the UIM (user interface module) located on the front of the solar water heater.

The Operating Set Point is adjustable from 90°F (42°C) to 140°F (60°C). The factory setting is 120°F (49°F). See the “Operating Set Point and Differential Adjustment” section in the solar water heater installation manual on how to adjust the Operating Set Point and other user settings.

Set the Operating Set Point at the lowest setting which produces an acceptable hot water supply. This will always provide the most energy efficient operation.

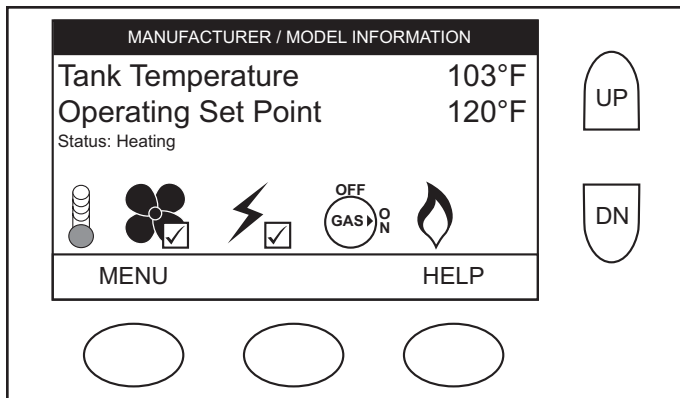

Figure 5.

HIGH TEMPERATURE LIMIT CONTROL (ECO)

This solar water heater is equipped with an ECO (energy cut out) non adjustable high temperature limit switch. The ECO switch contacts will open when the water temperature reaches approximately 202°F (94°C) and close at approximately 140°F (49°C).

If the ECO activates (contacts open) due to abnormally high water temperatures in the solar storage tank the control system will “lock-out” and will display the “Energy Cut Out” (ECO) fault message on the LCD screen. It is important that a Qualified Service Agent be contacted to determine the reason for the ECO activation before resetting the ECO. Once the reason has been determined and corrected the ECO can be reset per the “High Temperature Limit Control (ECO)” section of the solar water heater installation manual.

TANK SENSOR

The solar surface mount tank temperature sensor (installed) is located on the lower front of the solar water heater. The connection leads of the sensor extend out from the top cover and shall be connected to the controller in the tank sensor position by means of the use of sensor extension wires.

DRAINING AND FLUSHING

It is recommended that the solar water heater storage tank be drained and flushed every 6 months to reduce sediment buildup. The solar water heater should be drained if being shut down during freezing temperatures. See the Features and Components section for the location of the solar water heater components described below.

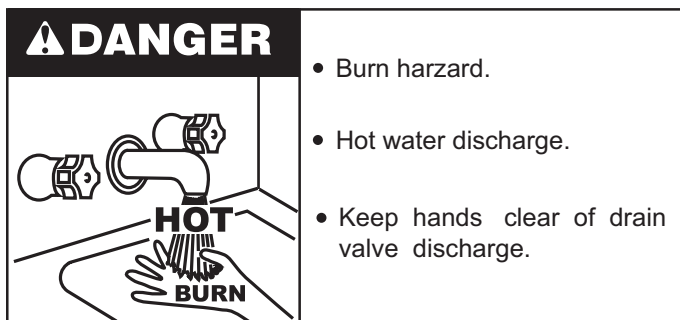

To drain the solar water heater storage tank:

1. Turn off the electrical supply to the solar water heater.
2. Turn off the gas supply at the Main Gas Shutoff Valve if the solar water heater is going to be shut down for an extended period.
3. Ensure the cold water inlet valve is open.
4. Open a nearby hot water faucet and let the water run until the water is no longer hot.
5. Connect a hose to the solar water heater drain valve and terminate it to an adequate drain.
6. Close the cold water inlet valve.
7. Open the water heater drain valve and allow all the water to drain from the storage tank.
8. Close the water heater drain valve when all water in the storage tank has drained.
9. Close the hot water faucet opened in Step 4.
10. If the solar water heater is going to be shut down for an extended period, the drain valve should be left open.

To Flush the tank perform the following steps:

1. Turn off the electrical supply to the solar water heater.
2. Ensure the cold water inlet valve is open.
3. Open a nearby hot water faucet and let the water run until the water is no longer hot. Then close the hot water faucet.
4. Connect a hose to the drain valve and terminate it to an adequate drain.
5. Ensure the drain hose is secured before and during the entire flushing procedure. Flushing is performed with system water pressure applied to the solar water heater.
6. Open the solar water heater drain valve to flush the storage tank.
7. Flush the solar water heater storage tank to remove sediment and allow the water to flow until it runs clean.
8. Close the solar water heater drain valve when flushing is completed.
9. Remove the drain hose.
10. Fill the solar water heater - see Filling the Solar Water Heater section.
11. Turn on the electrical supply to place the solar water heater back in operation.
12. Allow the solar water heater to complete several heating cycles to ensure it is operating properly.

POWERED ANODE RODS

To insure a long, trouble-free operating life, the solar water heaters covered in this manual are factory equipped with a powered anode system. The anode rods (2) are of a permanent design and do not need replacing unless damaged. Inspection and cleaning should be performed once a year.

Note: Follow the instructions to drain the solar water heater storage tank first. Remove the powered anodes from the solar water heater by loosening the 3/4" NPT bushing that forms the top of the anodes. Do not disassemble the retaining nut and wire terminal from the top while installed in the solar water heater, the anode's electrode may fall inside the tank. Remove the entire anode rod from the water heater prior to inspection. Clean the anode rods with a soft cloth and reinstall.

Hydrogen gas can be produced in a hot water system that has not been used for a long period of time (generally two weeks or more). Hydrogen gas is extremely flammable and explosive. To prevent the possibility of bodily injury under these conditions, open the hot water faucet for several minutes at the kitchen sink before any electrical appliances which are connected to the hot water system are used (such as a dishwasher or washing machine). If hydrogen gas is present, there will probably be an unusual sound similar to air escaping through the pipe as the hot water faucet is opened. There must be no smoking or open flame near the faucet at the time it is opened.

	! WARNING
	Explosion Hazard <ul style="list-style-type: none">• Flammable hydrogen gases may be present.• Keep all ignition sources away from faucet when turning on hot water.

SOLAR COLLECTOR INSTALLATION

COLLECTOR LOCATION

Proper location and orientation of the solar collectors is important for maximum system efficiency. The collectors should be unshaded from 10:00 am through 3:00 pm each day in every month of the year and should be located as close to the storage tank as possible to minimize heat loss in the piping runs. The best orientation is achieved when the collectors are facing due south $\pm 45^\circ$ and tilted at an angle from the horizontal equal to the latitude of the

location plus 10° . A steeper angle provides better winter performance as the sun is lower in the sky. The collectors will also shed snow more effectively at the steeper angle. Figure 6 below shows many alternatives for collector mounting. Placing the collectors as close as possible to the peak of the roof will make installation easier by providing increased attic access.

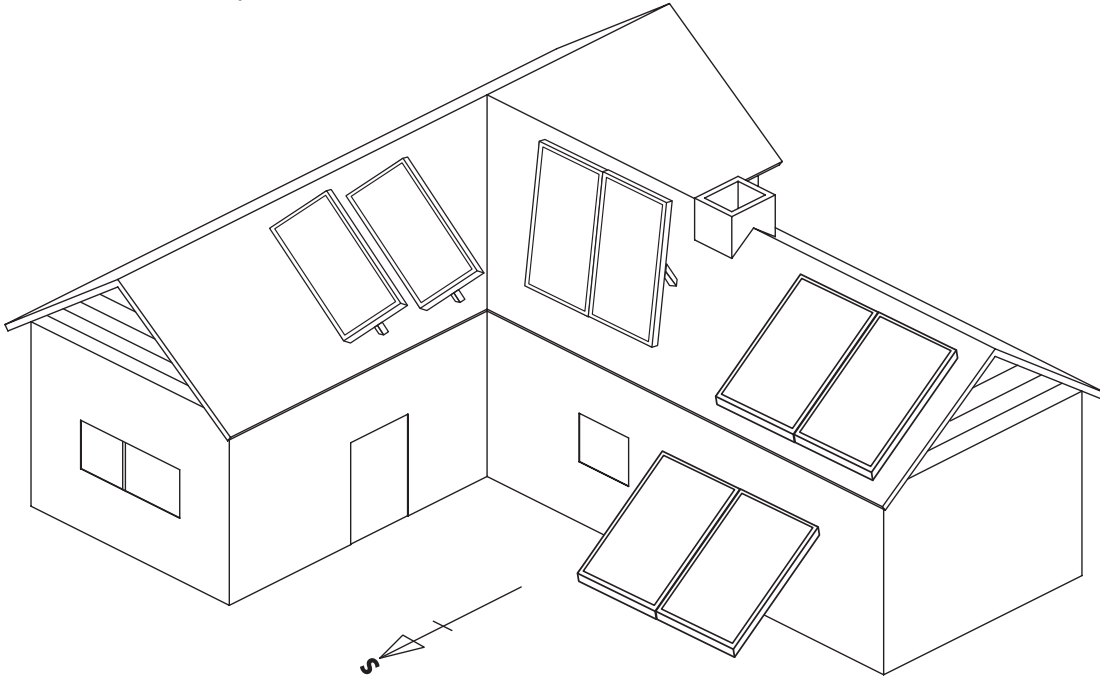

Figure 6.

GENERAL CONSIDERATIONS

The contractor shall obtain all required permits and approvals.

The installation shall conform to all federal, state and local regulations, codes, ordinances and standards governing solar water heating system installations and the contractor shall adhere to sound building safety and trade practices. Special consideration must be given to building code requirements for the penetration of structural members and fire rated assemblies.

Ensure the mounting surface is solid and able to withstand in excess of 330lbs / 150kg of pull force that may be encountered during high winds. Consult a structural engineer if in doubt.

The solar collector must be located in a structurally sound area of the roof that will be unshaded for the majority of the day all year round. Adjacent buildings and trees should be checked for possible winter shading. An instrument such as the Solar Pathfinder (www.solarpathfinder.com) can be used for solar site analysis.

Before the installation the contractor shall inspect the condition of the roof and notify the homeowner of any existing roof damage or necessary repairs.

COLLECTOR ORIENTATION

Proper tilt angle for solar collectors is latitude plus 10° . This 10° additional tilt improves performance in the winter, when the sun is weaker and at a lower angle. The cost in performance in the summer when the sun is high is overcome by the hours of sunlight and strength of irradiation that occurs in the summer. Tilt mounting accessory kits are available to set the proper collector angle. Please call your local dealer for more information.

When the collectors are mounted one behind the other, they should be spaced sufficiently apart so that when the sun is at its lowest altitude, the collectors will not shade each other and cause efficiency loss. See Figure 7 and Table 3.

If a collector must be installed horizontally, replace the upper vent with a rubber plug in order to prevent rain penetration. See Figure 8 & Figure 9.

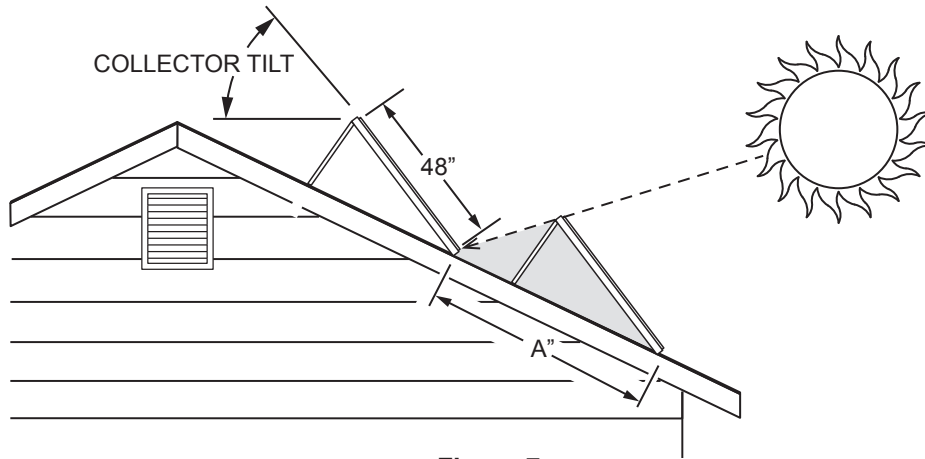

Figure 7.

LATITUDE			25° N	30° N	35° N	40° N	45° N	50° N	55° N	60° N	65° N
COLLECTOR TILT			35°	40°	45°	50°	55°	60°	65°	70°	75°
ROOF ANGLE & PITCH	ANGLE	PITCH	A" SPACING IN INCHES								
		0°	FLAT	87	103	127	159	213	260	330	446
	5°	1/12	76	87	103	122	151	174	204	244	295
	9°	2/12	69	78	90	104	123	139	157	180	205
	14°	3/12	63	69	78	88	101	111	123	136	149
	18°	4/12	59	64	71	78	88	96	105	115	123
	23°	5/12	54	59	64	70	77	83	89	96	102
	27°	6/12	52	55	59	64	70	75	80	86	90
	30°	7/12	50	53	57	61	66	70	75	79	83
	34°	8/12	48	51	54	57	61	65	69	72	75
	37°	9/12	N/A	49	52	55	59	62	65	68	70
	40°	10/12	N/A	48	50	53	56	59	62	65	66
	43°	11/12	N/A	N/A	49	51	54	56	59	62	63
	45°	12/12	N/A	N/A	48	50	53	55	57	60	61

Table 3.
(For All Horizontally Mounted Collectors)

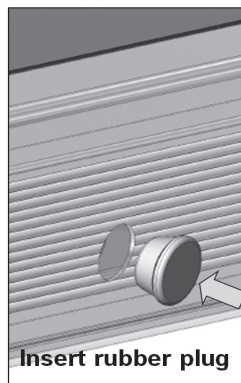
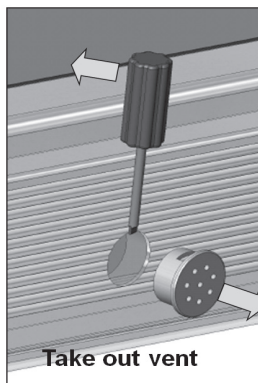
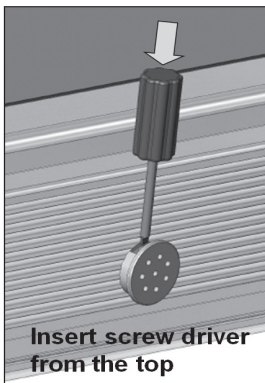

Figure 8.

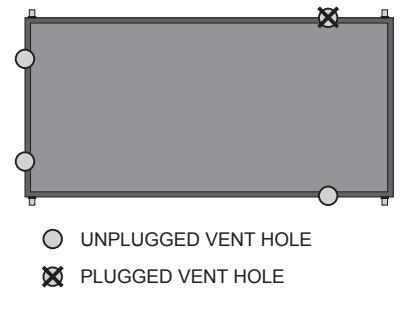

Figure 9.

CAUTION

ALL PERSONS WORKING ON ROOFS SHOULD HAVE SUCCESSFULLY COMPLETED A FALL SAFETY COURSE AND SHOULD BE PROPERLY EQUIPPED WITH THE APPROPRIATE SAFETY EQUIPMENT.

⚠ WARNING

AFTER COMPLETION OF THE COLLECTOR MOUNTING AND PRIOR TO SYSTEM CHARGING THE COLLECTORS MUST BE COVERED BY A BLANKET OR OTHER MEANS TO AVOID SOLAR RADIATION FROM HEATING THE COLLECTORS. THE SURFACES OF THE COLLECTOR CAN BECOME EXTREMELY HOT AND COULD POSE A BURN HAZARD.

The most important structural consideration is to securely anchor the solar collector and the mounting hardware to the structural members of the roof with the stainless steel hardware provided. The solar collector must be attached to the mounting hardware as detailed in Figure 14.

Preserving the integrity of the roof membrane is the most important roofing consideration. Ensure that all roof penetrations required to plumb and mount the solar collector are properly flashed and sealed in accordance with standard roofing practices.

If the region is subject to hurricane conditions, additional steps may be required to secure the collector and mounting hardware to the structural members. In certain areas of the country, local building codes may require collector wind load testing or prescribe specific mounting procedures. Consult your local building department.

Install the collectors as described in the Spanner Mounting instructions.

SPANNER MOUNTING

Although there are other installation methods for mounting solar collectors, it has been determined that the spanner mounting method is the most suitable for this application. Consult with your installer if other mounting means are required for your installation.

1. After locating the mounting points from Figure 10 for vertical collector mounting, Figure 11 for horizontal collector mounting, and Table 4, layout the roof as specified and drill 5/16" holes between the rafters where indicated.
2. Insert the flashing (not included with Standard Systems) so the top part is under the next row of shingles and the flashing hole/grommet aligns with the mounting hole. See Figure 12.
3. The compression bracket washer (not included with Standard Systems) is positioned over the flashing seal with the concave side towards the seal. See Figure 13.
4. The mounting bracket is then placed on the compression bracket washer (not included with Standard Systems).
5. A 12" length of stainless steel 5/16" all-thread is then inserted through the hole and a stainless steel nut, lock washer, and flat washer or EPDM bonded washer (not included with Standard Systems) secures the all-thread to the mounting bracket. The all-thread should extend about 4" below the roof rafters.

6. Fabricate spanners, one for each mounting bracket, using a 2" x 4" or similar lumber. Spanners must be long enough to span at least two rafters. In the attic or crawl space drill a 5/16" hole through each spanner and insert the all-thread through it. Secure each spanner to the rafters with decking or wood screws. See Figure 13.
7. Fabricate spacer blocks, one for each mounting bracket, using a 2" x 4" or similar lumber the same width of the rafter next to each all-thread. Place spacer blocks next to the all-thread between the spanner and roof. Secure each spacer block to the spanners with decking or wood screws. Spacer blocks are necessary to avoid deformation of the roof. See Figure 13.
8. With a stainless steel nut, lock washer and fender washer secure the all-thread to each spanner. Tighten down until the mounting bracket is tightly secured to the roof (approximately 97 inch pounds). Be careful not to overtighten and dish out the roof tiles underneath the mounting bracket.

Repeat steps 2 - 8 for the remainder of the mounting bracket locations.

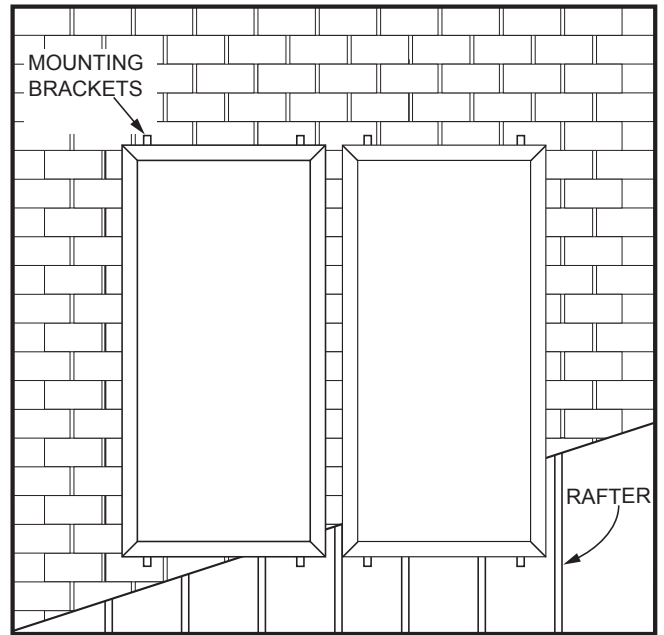
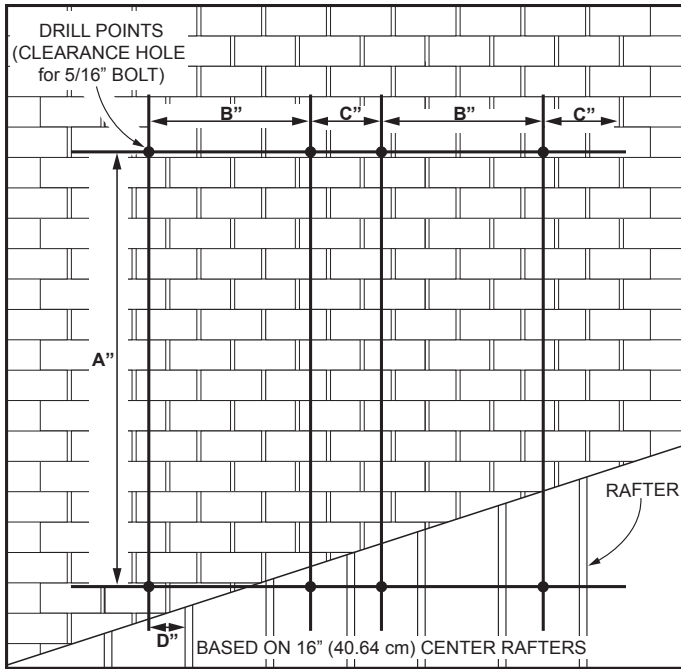

VERTICAL MOUNTING

Figure 10.

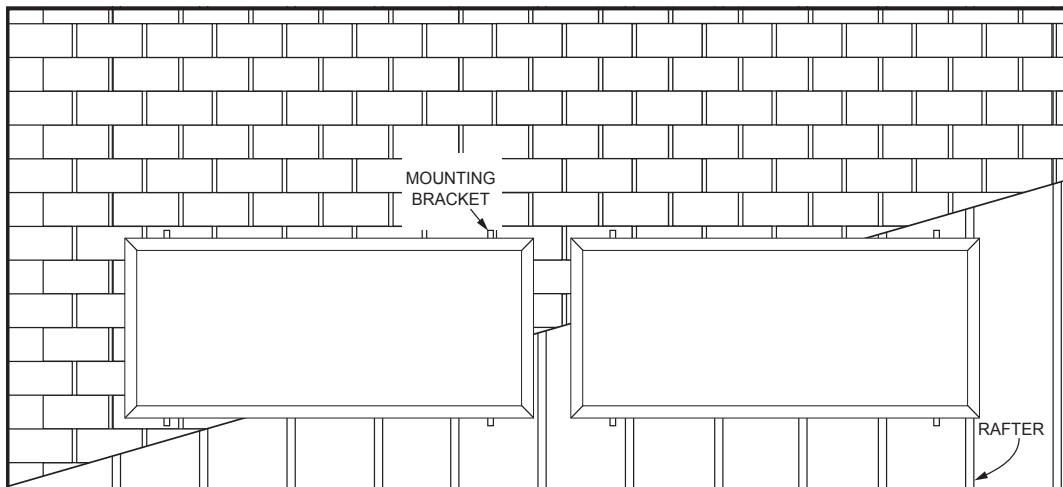
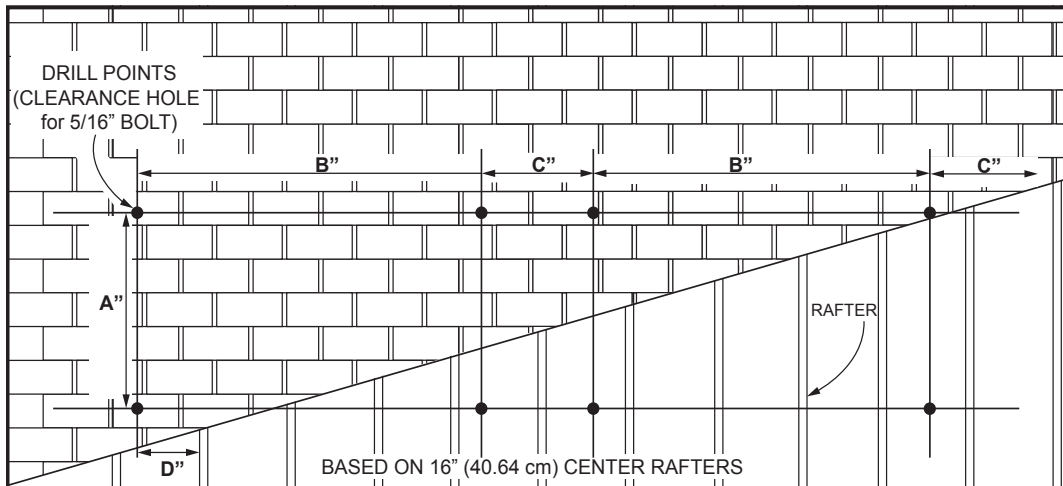

HORIZONTAL MOUNTING

Figure 11.

NOTICE

* IF MOUNTING WITH AN OPTIONAL TILT MOUNT KIT, FOR OPTIMAL COLLECTOR ANGLE REFER TO ITS INSTRUCTION SHEET FOR THE APPLICABLE "A" DIMENSION.

COLLECTOR	A	B	C	D
Vert. 3.5' X 7'	86"*	32"	14"	7-1/4"
Vert. 4' X 8'	97"*	35"	16"	11-3/4"
Vert. 4' X 10'	121"*	35"	16"	11-3/4"
Horiz. 3.5' X 7'	42.25"*	62"	28"	13-1/2"
Horiz. 4' X 8'	47"*	72"	28"	12"
Horiz. 4' X 10'	47"*	94"	30"	9"

Table 4.

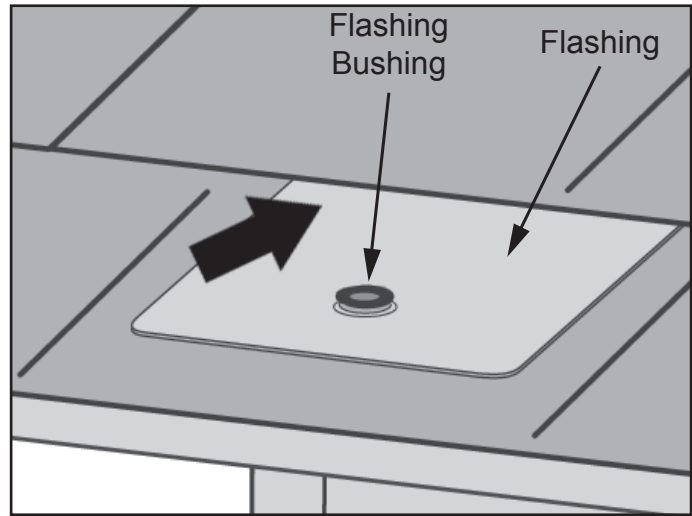

Figure 12.

(Not Included with Standard Systems)

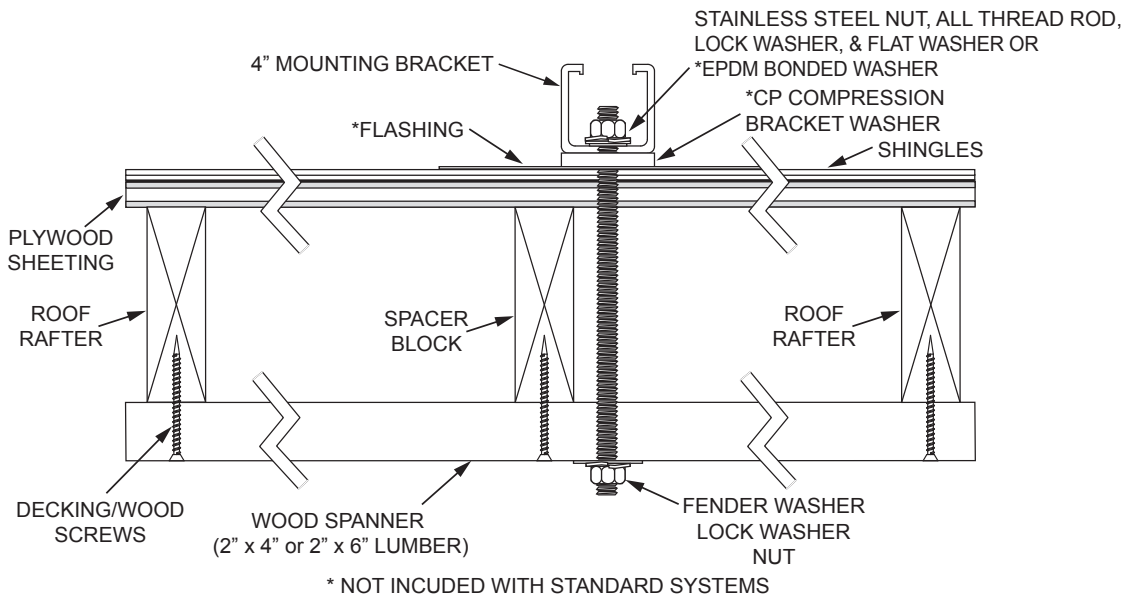

Figure 13.

ATTACHING COLLECTOR TO MOUNTING BRACKETS

Once all of the mounting brackets have been secured to the roof the solar collector(s) can be installed. Refer to Figure 14 for these instructions.

1. Insert the stainless steel channel nut w/spring inside of the mounting bracket.
2. Fasten the solar collector mounting clip to the channel nut with the stainless steel bolt, lock-washer, and flat washer as shown. Do not tighten. Repeat step for the other mounting bracket locations.
3. The solar collector can now be set on the mounting brackets. To aid in handling the collectors on the roof the mounting clips may be tightened to the lower mounting brackets prior to raising the collectors.
4. After the solar collector is in position, locate the upper mounting clip so that its lip over-hangs the lip of the solar collector frame as shown. Tighten the mounting clip to the solar collector frame securely. Repeat for the other upper mounting clips.
5. Once the upper mounting clips are secured, the bottom mounting clips can be loosened and retightened over the collector lip as directed in step 4.
6. Repeat steps as needed for other solar collectors.

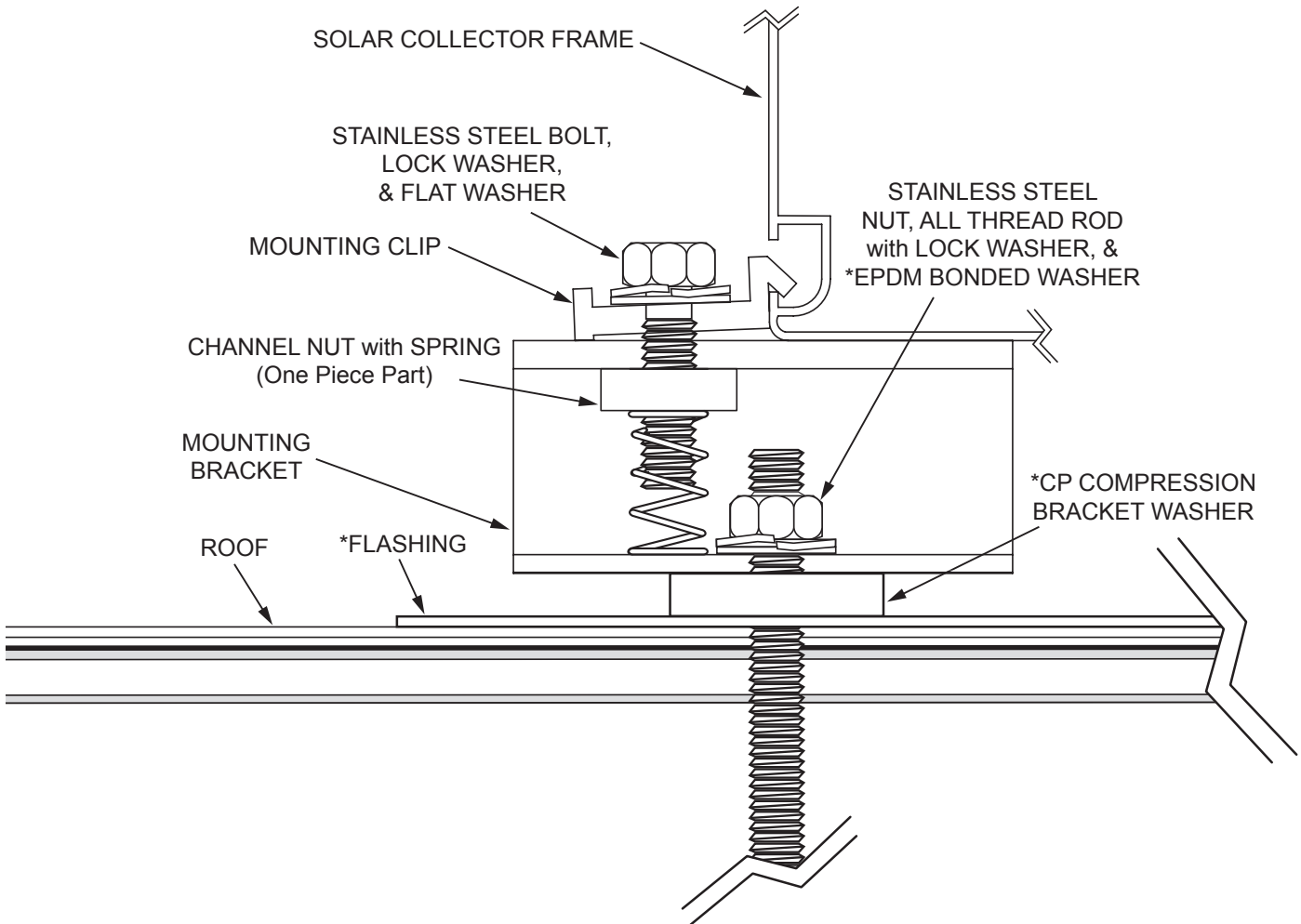

Figure 14.

* Not included with Standard Systems.

COLLECTOR PIPING

The piping of the system should be considered before a final decision is made on how the collectors are mounted. Piping should be made of copper tube of the type meeting local codes, insulated with Armacell UT Solaflex or equivalent. The maximum total piping length allowed in this system is 200 equivalent ft.

Use only lead-free solder. Use of 50/50 lead solder is expressly prohibited. Use only type "L" or "M" copper tubing in the collector loop plumbing. Use of galvanized steel, CPVC, PVC, PEX or any other type of plastic pipe is prohibited.

Care should be taken in the spacing of collectors as attachment of piping is easiest with properly aligned collectors. The connection between the collector panels is made with copper unions or couplings. To aid in installation the collector array layout should be planned on the ground and the unions or couplings soldered to the adjoining headers prior to lifting the collectors to the roof. Similarly the top and bottom outside header that will not be used for the inlet or outlet (should be on opposite sides) should be capped with 1" copper caps while on the ground. Refer to Figure 15 and Figure 16 for typical horizontal and vertical collector piping layouts. These typical piping layouts are designed to maintain the proper fluid flow rate through each collector.

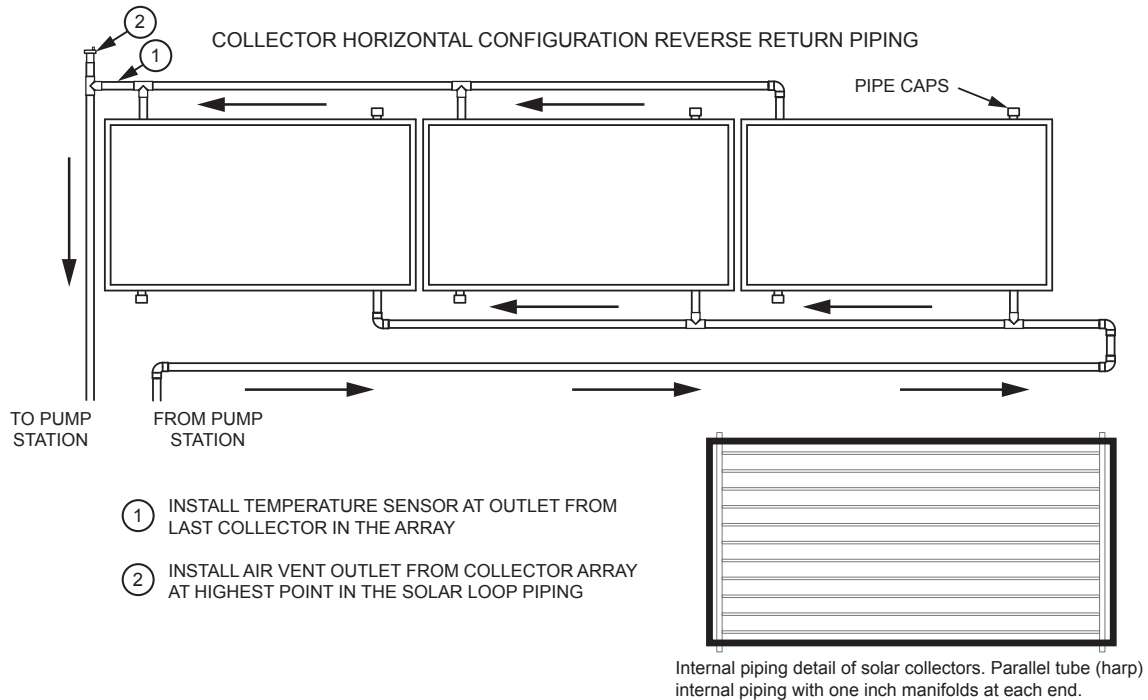

Figure 15.

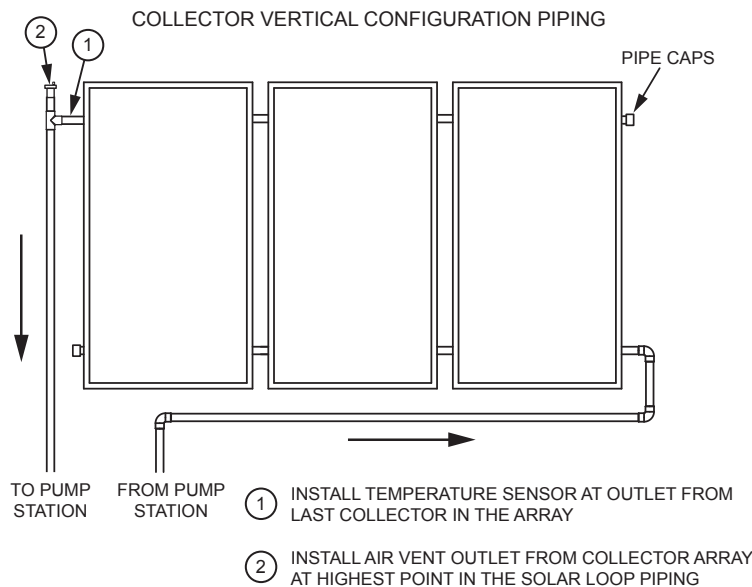

Figure 16.

COLLECTOR PIPING DETAIL

The outlets of the collector are 1" copper pipe nipples. See Figure 17. They should be piped as shown with provisions for an air vent and air vent isolation valve. The air vent must be oriented vertically as this must be the highest point in the system in order for air to escape. This will prevent air lock and subsequent loss of system efficiency. Teflon® tape or high temperature, high quality pipe sealant should be used when making threaded connections.

The collector inlets should be piped similarly but without the air vent.

SENSOR MOUNTING AT COLLECTOR

The angled collector heat sensor is mounted to the outlet of the collector. See Figure 17. The stainless steel screw clamp should be used. The entire sensor should be wrapped thoroughly with insulating stretch tape so that the sensor is isolated from the outside air. If possible route the sensor wire through the roof flashing and connect the sensor wire to the sensor extension wire provided with wire nuts.

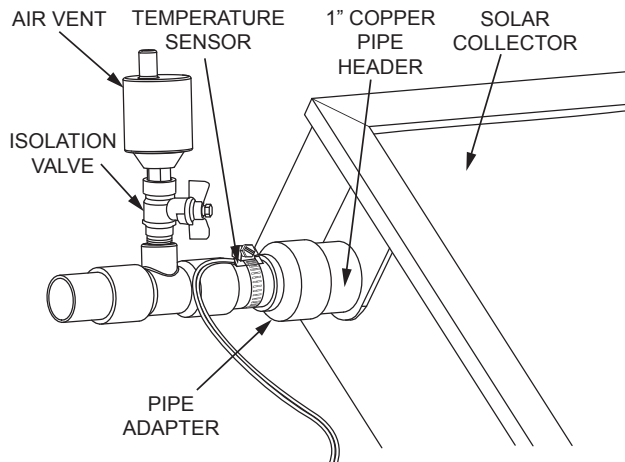

Figure 17.

PIPING THROUGH THE ROOF

Note: Solar piping flashing not included with Standard Systems

Penetration of the building through which piping or wiring is passed shall not reduce or impair the function of the enclosure. Penetrations through the wall or other surfaces shall not allow intrusion by insects and/or vermin. Required roof penetrations shall be made in accordance with applicable codes and also practices recommended by the National Roofing Contractors Association.

Piping through the roof should be weatherproofed as shown in Figure 18. Three-quarter inch holes are drilled through the roof on the same plane as the supply and return header pipes. Do not drill the hole above the supply header of the collector. This will prevent the collector

from draining. Placing the hole below the supply header is acceptable, but it is more aesthetic if it is located on the same plane. The flashing plate is placed over the hole with its base cemented to the roof and its upper edges slid under the adjoining shingle. The copper tube supply line is then pushed up through the hole in the flashing. The same procedure is then repeated for the return line and flashing. The sensor wire should also be run through the gooseneck of the return flashing. The copper lines should be soldered to the flashings coolie cap to ensure proper seal. The return and supply lines should be supported under the roof to prevent undue stress on the piping assemblies at the collector. Hangers shall provide adequate support and correct pitch of pipes. Hangers or supports for insulated pipes or components shall avoid compressing or damaging the insulation material. Piping should be sloped toward drain ports with a drainage slope of no less than 2 cm vertical drop for each meter of horizontal length (1/4 inch per foot).

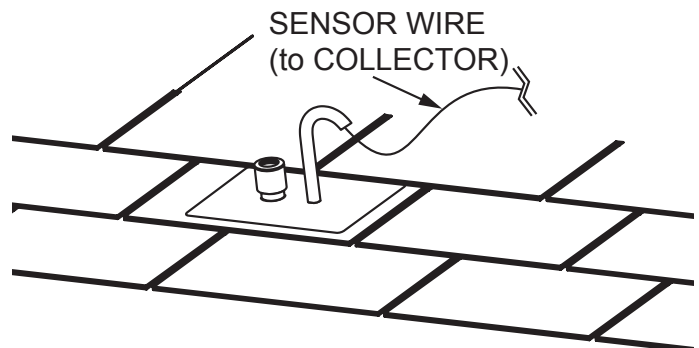

Figure 18.

PIPE INSULATION

The collector loop piping (exterior and interior) must be well insulated with high temperature resistant (300°F/149°C) good quality flexible EPDM closed cell insulation to minimize heat loss. The recommended insulation is Armacell UT Solaflex or equivalent. The wall thickness of the pipe insulation should not be less than 3/4". A 1" wall thickness is required in all areas prone to annual hard freeze conditions. When it comes to pipe insulation the rule is simple: thicker is better. As part of the insulation requirements the final 5 ft (1.52 m) of the cold water inlet to the storage tank must be insulated.

To the extent possible, slide the insulation material over the pipe without cutting or taping. All butt joints must be sealed with high temperature contact adhesive. The use of rigid polyethylene pipe insulation is prohibited. All outdoor insulation should be protected from moisture and Ultraviolet deterioration by either paint or protective over-sleeving. Insulation to complete the outdoor portion of the installation has been provided.

PUMP STATION INSTALLATION

PUMP STATION

The following instructions describe the installation, start-up, function and operation of the solar pump station. The solar pump station may only be used in the collector circuit of a solar thermal installation. The technical data specified in these instructions must be observed. Improper usage excludes any liability claims.

The wrapping materials that form the outer shell of the pump station are made of recyclable materials and can be disposed of with recyclable materials.

The solar station is a pre-mounted valves and fittings group checked for leakage used to circulate the solar fluid in the solar circuit.

SAFETY INSTRUCTIONS

The installation and start-up of the solar station as well as the connection of electrical components require technical knowledge commensurate with a recognized vocational qualification such as a fitter for plumbing, heating and air conditioning technology, or a profession requiring a comparable level of knowledge [specialist]. The following must be observed during installation and start-up:

- Relevant local and national codes
- Accident prevention regulations of the professional association
- Instructions and safety instructions mentioned in this manual

SOLEX PUMP STATION COMPONENTS

With cover on:

- A. Front Cover
- B. Differential temperature controller
- C. Temperature gauge (red) with immersion sleeve for insertion into the solar supply ball valve
- D. Temperature gauge (blue) with immersion sleeve for insertion into the solar return ball valve

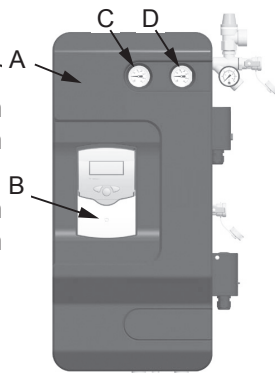

Figure 19.

The solar ball valves (E & F) are equipped with spring-charged check valves to prevent gravity circulation.

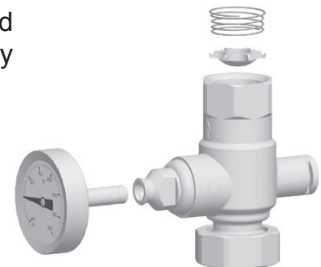

Figure 20.

Primary (solar) loop with cover removed:

- E. Ball valve with integrated temperature gauge and check valve, solar supply
- F. Ball valve with integrated temperature gauge and check valve, solar return
- G. Pressure relief valve for avoiding over-pressure condition
- H. Fill valve
- I. Pressure gauge and connection for expansion tank
- J. Solar loop circulation pump
- K. Flow meter to display the flow rate
- L. Drain valve
- M. Double wall heat exchanger
- N. Air scoop

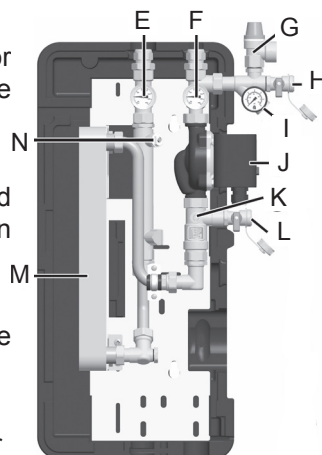

Figure 21.

Secondary (storage tank) loop with cover removed:

- O. Storage tank loop air vent
- P. Water heater circulation pump
- Q. Temperature sensor supply
- R. Temperature sensor return

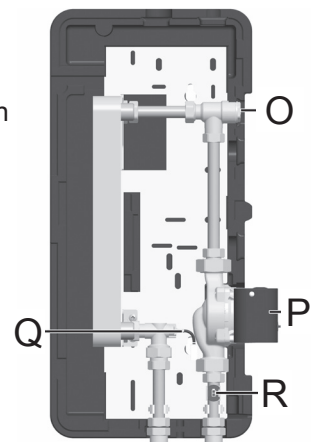

Figure 22.

SAFETY EQUIPMENT

For protection against excessive pressures in the collector loop a pressure relief valve is integrated into the solar pump station. A drain pipe must be installed in the valve outlet so that any discharge will exit only within 6 inches above, or at any distance below the structural floor. Be certain that no contact is made with any live electrical part. The discharge opening must not be blocked or reduced in size under any circumstances. Excessive length, over 15 feet, or use of more than two elbows can cause restriction and reduce the discharge capacity of the valve.

Do not connect the drain pipe directly to discharge drain unless a 6" air gap is provided. To prevent bodily injury, hazard to life, or damage to property, the relief valve must be allowed to discharge fluid in quantities should circumstances demand. If the discharge pipe is not connected to a drain or other suitable means, the fluid may cause property damage.

WALL MOUNTING THE SOLAR PUMP STATION

ATTENTION: TO PREVENT DAMAGE TO PROPERTY, THE LOCATION OF INSTALLATION MUST BE DRY, LOAD-CARRYING AND FROST-PROOF TO PREVENT MATERIAL DAMAGE TO THE INSTALLATION.

1. Choose the position to install the solar pump station next to the storage tank .
2. Mark the location of the hanging holes on the wall (15" apart vertically)

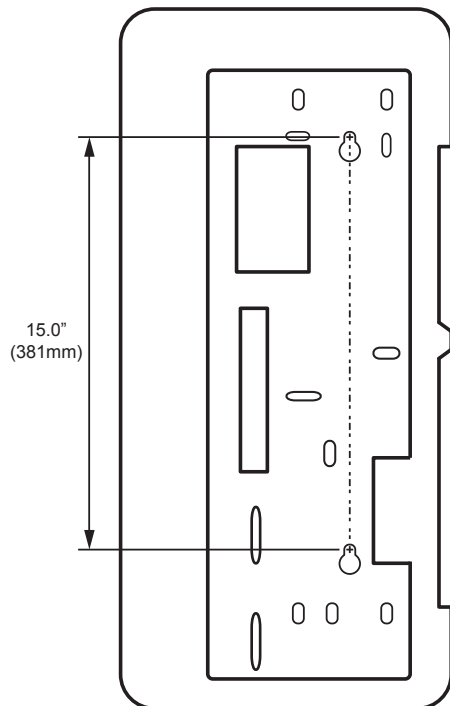

Figure 23.

3. Pre-drill holes and insert the enclosed 4.5" hanging screws so that about 1" of each screw still stick out..
4. Remove the front cover of the solar station and hang the station onto the screws then tighten the screws.
5. Mount the solar safety group to the connection above the return ball valve.

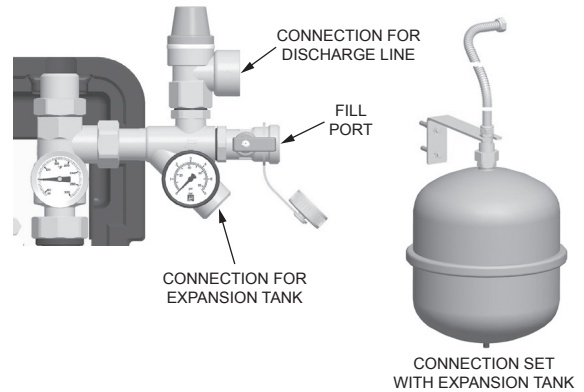

Figure 24.

6. Connect a discharge line to the pressure relief valve in the solar circuit
7. Connect the stainless steel corrugated hose to the safety group. Do not forget to insert the seal.
8. Choose the position for the expansion tank bracket on the wall beside the solar pump station. Fasten the bracket to the wall with the enclosed hardware (masonry or drywall).
9. Unscrew the tank connector (Figure 25) to separate the two halves. The top half should be pushed onto the mounting bracket and the lock ring tightened. The bottom half should be attached to the 3/4" threads on the expansion tank.

NOTE: The tank connector allows you to isolate the expansion tank from the solar circuit. See Figure 25. When the nut is unscrewed the valves in each half of the tank connector are automatically closed tightly by the integrated springs. Each side remains closed until the two halves are screwed back together and the valves are forced open. Do not forget to insert the seal.

The expansion tank should not be connected to the system until it has been flushed and charged.

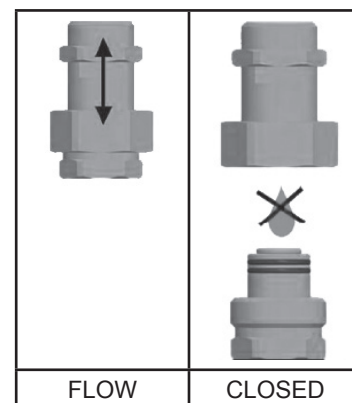

Figure 25.

10. Check and set the pressure of the air bladder in the expansion tank to 25 PSI. If the pressure is higher bleed pressure out until it is correct. If the pressure is too low add air by use of a compressor or bicycle pump until the pressure is correct.
11. Plumb the solar pump station to the storage tank and to the collector: The tank connections should use $\frac{3}{4}$ " copper pipe and can be connected using the threaded adaptors provided. The collector connections should use $\frac{1}{2}$ " copper pipe and can be connected with the compression fittings provided. The total piping run in the solar loop should not exceed 200 equivalent feet. Failure to limit the line length may cause poor system performance and lead to premature pump failure.
12. Install a discharge pipe to the pump station relief valve that must terminate a maximum of six inches above a floor drain or external to the building.

Installing the $\frac{1}{2}$ " copper to and from the collector using the compression fittings.

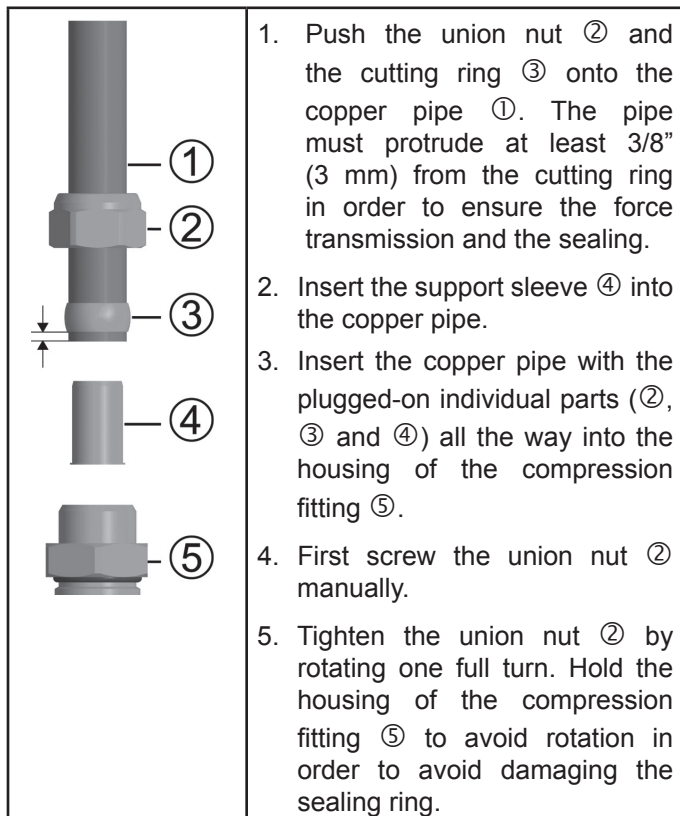

Figure 26.

PLUMBING CONFIGURATION

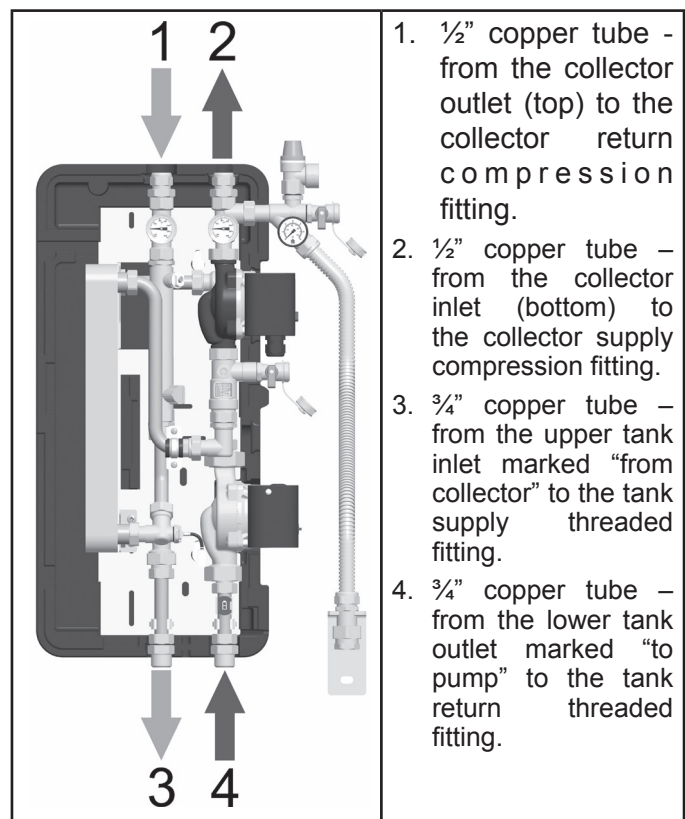

Figure 27.

FUNCTION

Refer to Figure 19 thru Figure 22.

Check valves

The solar station is equipped with check valves in the supply and the return ball valve (E, F).

For filling, venting and flushing of the installation the check valves must be turned to the correct position. To set the proper position for the check valves take off the temperature gauges (E, F), remove the top cover (A) and turn the ball valves into the proper position using a wrench. See Figure 28. In the 45° position the balls in the ball valves push the check valves open.

During operation the ball valves must be in the 0° position.





0°	45°	90°
		
		
Check valve is operating, flow only in flow direction	Check valve is not operating, flow in both directions.	Ball valve closed, no flow.

Figure 28.

FLOWMETER

The flowmeter serves to measure and display flow volume of the system in a range of 0.8-6.0 US gpm.

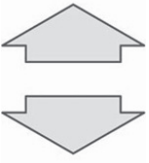
In order to guarantee the flawless function of the measuring device the installation must be flushed and free from foreign substances.

The flowmeter must be mounted vertically.

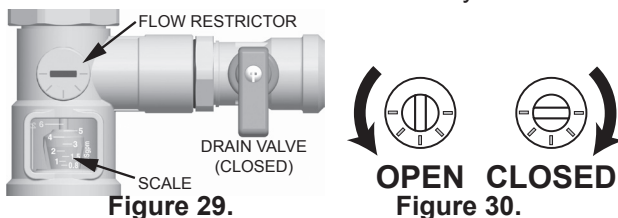

Figure 29.

Figure 30.

Use a flat head screwdriver to adjust the flowmeter. Read the flow rate from the upper edge of the floating body.

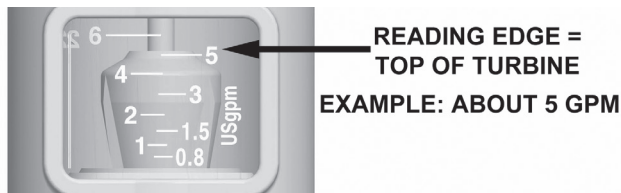

Figure 31.

START-UP & OPERATION - SOLAR PUMP STATION

Observe the following safety instructions when starting up the solar thermal installation:

DANGER

To prevent the solar fluid from boiling in the collectors, the installation should not be flushed or filled during periods of strong sunshine or the panels should be covered with a blanket to keep collectors cool.

LEAK DETECTION

Refer to Figure 19 thru Figure 22.

1. Disconnect the expansion tank from the solar system by unscrewing the nut on the tank connector. This prevents the access of dirt particles present in the pipes from entering the expansion tank.
2. Remove the front cover of the solar station and the temperature gauges from the ball valves (E, F)
3. Turn the two isolation ball valves (E, F) to 45° using an appropriate wrench to allow flow in both directions.
4. Close the drain valve (L).
5. Be sure the air vent at the collector array is closed.
6. Connect an air pressure hose to the fill valve (H) above the pressure gauge (I) and open this valve.
7. Using an air compressor or pressurized air tank fill the system with pressurized air until the pressure gauge (I) reads 40 psi then close the fill valve (H).
8. The pressure should hold steady for 15 minutes. If the pressure falls it is an indication of a leak. Find and repair the leak then repeat steps 6 and 7 watching for the pressure to hold at least 15 minutes. After the pressure test slowly open the drain valve (L) to release the air pressure on the system.

FLUSHING

Refer to Figure 19 thru Figure 22.

CAUTION

SOLAR THERMAL INSTALLATIONS CANNOT BE COMPLETELY EMPTIED AFTER FLUSHING. THERE IS A DANGER OF FROST DAMAGE IF WATER IS USED FOR FLUSHING. ONLY USE WATER TO FLUSH THE SYSTEM WHEN THE OUTSIDE TEMPERATURE IS ABOVE 32° F, OTHERWISE USE THE SOLAR FLUID TO FLUSH MAKING SURE TO FILTER ANY DEBRIS BEFORE FINAL FILLING. USE A WATER / PROPYLENE GLYCOL MIXTURE AS A SOLAR FLUID (MAXIMUM 50% PROPYLENE GLYCOL).

9. Disconnect the air pressure hose from the fill valve (F)
10. Connect a water hose from a water source with at least 40 PSI supply pressure to the fill valve (F).
11. Connect a discharge hose to the drain valve (L) and open this valve. Place the other end of the discharge hose into an appropriate drain.
12. Turn the supply ball valve (F) to 90° (horizontal) so that the valve is closed.

13. Turn on the supply water and open the fill valve (H) then leave running for 15 minutes to flush debris out of the solar loop
14. After the 15 minute flush turn off the supply water at the source and allow the system to drain. When water stops flowing out of the discharge hose close the fill valve (H)
15. Close the drain and fill valves (H & L) on the pump station and disconnect the water source hose.

FILLING THE STORAGE TANK LOOP

Refer to Figure 19 thru Figure 22.

The storage tank loop is filled with potable water by means of the valves and fittings of the storage tank.

16. Fill the storage tank following the procedures in the tank section of this manual and the manual included with the solar storage tank.
17. Vent the storage tank loop by opening a nearby hot water faucet and the storage tank loop ball valve (O) to avoid trapped air in the storage tank loop of the pump station and burn out of the water heater heating element.
18. Close the faucet and solar loop air vent (O) after all air has been purged and the water comes out with constant flow.

PREPARATION OF THE HEAT TRANSFER FLUID

Pour 100% Propylene Glycol (such as Dowfrost™) into a large clean bucket. Add an equivalent amount of distilled or de-mineralized water for a 50/50 solution by volume.

The use of regular tap water as a mixing agent is prohibited. Distilled or de-mineralized water is often available from grocery stores and drugstores. This solution provides freeze protection down to -30°F and burst protection down to -60°F.

Use of heat-transfer fluid other than a maximum 50/50 mix by volume of Propylene Glycol and distilled or de-mineralized water is not permitted. Use of any heat-transfer fluid other than that specified by the appliance manufacturer will void warranty, and may result in poor performance, equipment damage, or risk to health and safety.

No other fluids shall be used that would change the original classification of this system. Unauthorized alterations to this system could result in a hazardous health condition.

FILLING THE SOLAR LOOP

Refer to Figure 19 thru Figure 22.

1. Connect a discharge hose to the drain valve (L) and place the discharge end of the hose into the glycol solution container.
2. Turn the return ball valve (E) to 0° (vertical) so that flow is only allowed in the proper direction.
3. Connect a fill hose from the glycol container to a 1/2 HP transfer pump and another hose from the transfer pump to the fill valve (H) then open this valve.
4. In order to flush as much air as possible from the system, turn on the transfer pump to fill the system with

the glycol solution and allow to circulate for 15 minutes or until no bubbles are returning to the collector.

5. Open the air vent isolation valve and air vent at the top of the collector array 1 -3 turns to allow air to disperse.
6. Remove the cap from the air scoop and open its vent (N) with a flat head screwdriver. This will release air captured by the system during circulation. Cover small outlet port with a rag as fluid will be ejected after the air is evacuated. After all air has been evacuated, close the air scoop vent and replace the cap.
7. Turn the supply ball valve (F) to 0° (vertical) so that flow is only allow in the proper direction.
8. With the transfer pump still running close the drain valve (L) and allow the system to rise to an operating pressure of 30 psi on the pressure gauge then close the fill valve and turn off the pump. If the pressure has exceeded 30 psi after the pump is off the slowly open the drain valve (L) and relieve pressure until the pressure gauge reads 30 PSI then close the drain valve.
9. Connect the expansion tank and verify the system pressure. If it has dropped open the fill valve (H) and turn on the transfer pump. Repeat system pressure setting in step 8.
10. Remove the fill and drain hoses and close the fill and drain valves (H, L) with the caps provided. The caps only serve to protect the valves against dirt. They are not designed to withstand high system pressures, the valves must be closed.

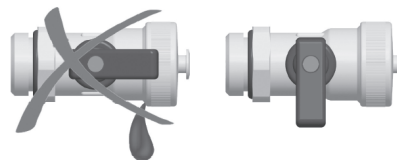

Figure 32.

11. Plug in the solar pump station to a 115V outlet and turn the pump on using the manual mode (see the PUMP STATION CONTROL INSTRUCTIONS).
12. Switch on the pumps using the manual mode.
13. Adjust the solar pump speed using the pump speed selector on the side of the pump (J). Set the speed to the lowest level possible to achieve the recommended system flow rate. See Table 5.

		NUMBER OF COLLECTORS			
		1	2	3	4
COLLECTOR SIZE	3.5' x 7'	0.7	1.4	2.1	2.8
	4' x 8'	1.0	2.0	3.0	4.0
	4' x 10'	1.3	2.6	3.8	5.0
		FLOW RATE IN GPM			

Table 5.

14. Adjust the storage tank pump speed using the pump speed selector on the side of the pump (P). Set the speed to be one level lower than that of the solar pump.

15. Cycle the pumps on and off in manual mode to check whether the starting torque is sufficient with the pump speed selected. If flow does not start properly a higher speed may need to be selected. Again check the installation for leaks and ensure both ball valves are open completely.
16. Re-insert the temperature gauges and replace the front cover.
17. Set both pumps on the controller to operate in automatic mode. See control operation section.
18. After the system has been running for several days close the air vent and the air vent isolation valve located at the top of the collector array.

DRAINING THE SOLAR LOOP

Refer to Figure 19 thru Figure 22.

1. Switch off the controller by unplugging the power supply from the outlet.
2. Open the check valves in the supply and the return ball valves (E,F) by turning the ball valves to position 45° with an appropriate wrench
3. Place a temperature-resistant container under the drain valve (L)

4. Connect a temperature resistant hose to the drain valve (L) with the discharge end placed in the collection container.

	<p>! DANGER</p> <p>The discharged fluid can have very high temperatures. Place the collecting container so that people standing nearby are not endangered when the solar thermal system is being emptied.</p>
--	--

5. Open the drain valve at the lowest point. of the thermal installation.
6. Open the air vent and air vent isolation valve at the top of the collector array. This will serve as a vacuum break to aid in draining.
7. Dispose of the solar fluid observing any local codes.

ATTENTION: Upon completion of the pump station installation and prior to pump station start-up the included pump station valve diagram label must be attached to the pump station piping so that it is in plain view.

PUMP STATION CONTROL INSTRUCTIONS

CONTROL INSTRUCTIONS

! WARNING

Electrical Shock Hazard

- Before removing any access panels or servicing the pump station, make sure the electrical supply to the pump station is turned off.
- Failure to do this could result in death, serious bodily injury, or property damage.

! WARNING

ESD SENSITIVE

Electrostatic discharge can lead to damage of electronic components.

Prior to operation of the control on the solar pump station the collector and tank temperature sensors must be properly connected. Remove the control cover and connect the sensors to the proper terminals.

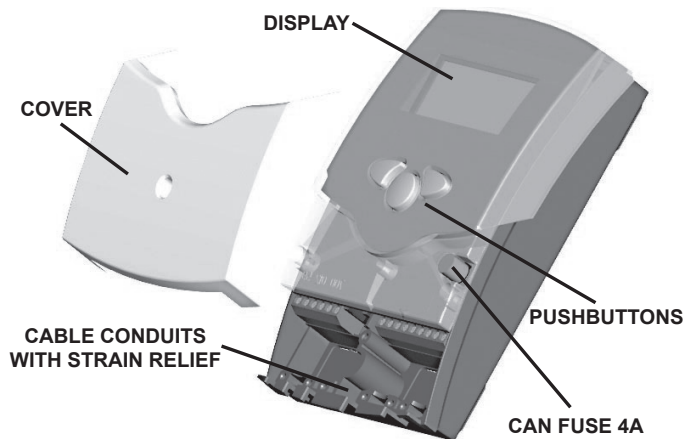

Figure 33.

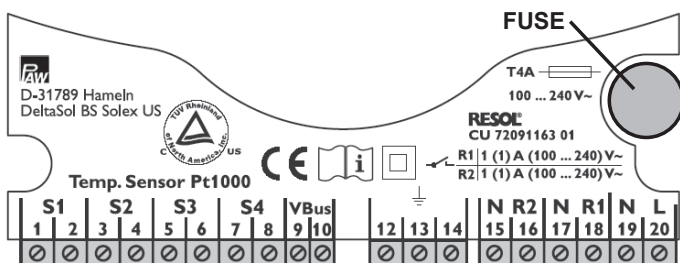

Figure 34.

The temperature sensors should be connected to the following terminals with no dependence on polarity:

- 1 / 2 = sensor 1 (collector outlet)
- 3 / 4 = sensor 2 (lower heat exchanger sensor - pre-installed)
- 5 / 6 = sensor 3 (tank sensor)
- 7 / 8 = sensor 4 (upper heat exchanger sensor - pre-installed)
- 9/10 = VBus (see VBus note)

The power supply is connected to the following terminals:

- 19 = Neutral - N
- 20 = Line power - L
- 12 = Ground (⊥)

The control is equipped with two relays, one for the solar loop pump (upper - primary) and one for the water loop pump (lower - secondary)

- Relay 1 (primary pump)
 - 18 = Line power - R1
 - 17 = Neutral - N
 - 13 = Ground (⊥)
- Relay 2 (secondary pump)
 - 16 = Line power - R2
 - 15 = Neutral - N
 - 14 = Ground (⊥)

The controller is equipped with a VBus® for data transfer with an energy supply to external modules (not included). The connection is carried out at the terminals marked "VBus" and is not polarity dependent.

SYSTEM DESCRIPTION

The DeltaSol® BS Solex US controller is used in solar thermal systems with an external heat exchanger which separates the solar loop from the domestic hot water loop.

The controller calculates the temperature difference between the collector sensor S1 and the tank temperature sensor S3. If this temperature difference reaches the switch-on temperature difference, the primary loop pump is switched on. If the temperature difference falls below the switch-off difference the pump is switched off.

If the switch-on temperature difference between the upper heat exchanger sensor S4 and the tank temperature sensor S3 is reached, the secondary loop pump will be switched on.

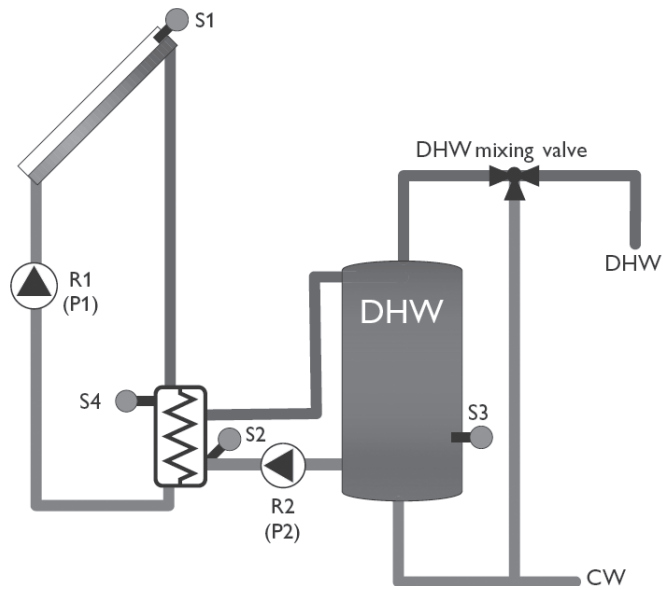

Figure 35.

SENSOR	DESCRIPTION
S1	Collector sensor
S2	Secondary loop heat exchanger sensor
S3	Tank sensor
S4	Primary loop heat exchanger sensor
RELAYS	DESCRIPTION
R1	Primary loop pump
R2	Secondary loop pump

Table 6.

OPERATION AND FUNCTION

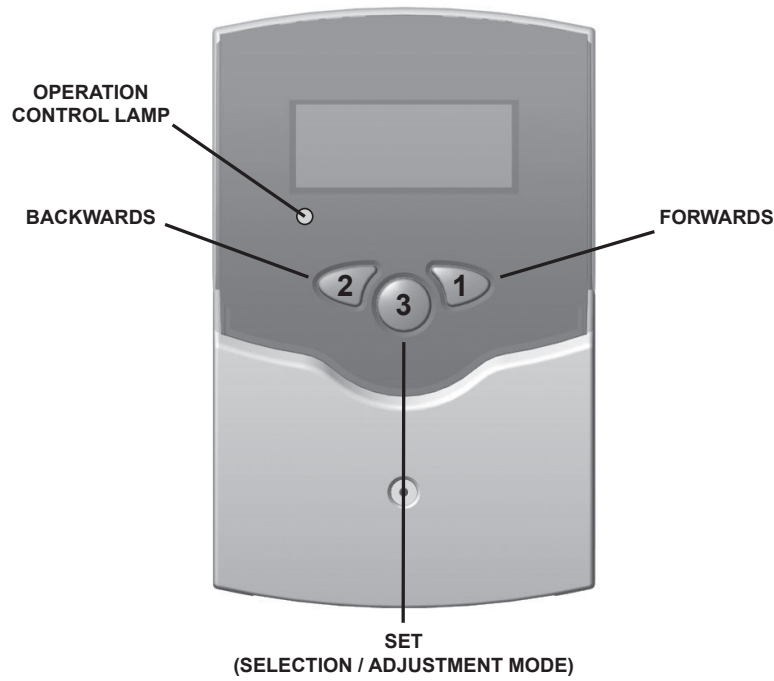

Figure 36.

The controller is operated by 3 push buttons below the display. The forward key (1) is used for scrolling forward through

the indication menu or to increase the adjustment values. The backwards key (2) is used for scrolling backward through the indication menu or to decrease the adjustment values.

For system settings adjustment press the forward key to reach the last display channel. Then hold the forward button down for 2 seconds and the system setting screens can then be shown. If an adjustable value is shown on the display **SET** is indicated. To change the set value press the Set button (3) so that **SET** flashes. Adjust the value using button 1 or 2 until the desired value is shown then press button 3 so that **SET** permanently appears. The adjusted value is now saved.

System Monitoring Display

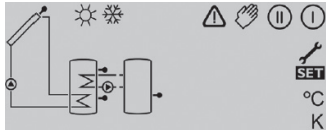

System screen with toolbar

The system monitoring display consists of 3 blocks: channel indication, the toolbar, and system screen.

The channel indication consists of two lines. The upper line is an alphanumeric 16 segment indication in which the channel name or menu item is shown. The lower 7 segment indication shows the channel value and the adjustment parameters are indicated.



Channel display

Temperatures are indicated in °F / °C, Temperature differences are indicated in °F / K

The symbols in the toolbar indicate the current system status:

STATUS	STANDARD	FLASHING
An adjustment value is being changed - SET MODE		SET
Relay 1 active	ⓘ	
Relay 2 active	Ⓜ	
Maximum tank temperature reached	☀	
Tank Emergency shutdown active		⚠+☀
Collector emergency shutdown active		⚠
Collector minimum limitation active		❄
Antifreeze function activated	❄	
Antifreeze function active	ⓘ/Ⓜ	❄
Manual operation relay 1 ON	✋+ⓘ	⚠
Manual operation relay 2 ON	✋+Ⓜ	⚠
Manual operation relay 1 / 2 OFF	✋	⚠
Sensor error	🔧	⚠

Blinking control symbols

- Pump is blinking while running
- Sensors are blinking if the respective sensor indication channel is selected
- Sensors are quickly blinking if there is a sensor error

Operation control lamp indication

Constantly green:	system operation normal
Red/green blinking:	initialization phase / manual operation
Red blinking:	sensor error

STARTUP / SYSTEM SETTINGS

The AC power cord should be plugged in to an appropriate 115V outlet. The controller will enter an initialization phase in which the operating control lamp will flash red and green. After the initialization period the controller will be in automatic operation with the default settings active.

When the controller is commissioned for the first time or after a system reset, it may run a commissioning menu. The commissioning menu leads the user through the most important adjustment channels for operating the system.

Commissioning Menu:

Unit:

Adjust the unit in which the temperatures and temperature difference shall be displayed

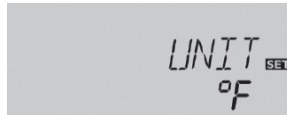

Time:

Adjust the current time for the real time clock.

The hours and minutes have to be adjusted separately, first the hours, then the minutes. Time format is 24 hours, e.g. 15:00h = 3 pm



Switch-on difference of primary loop

Adjust the switch-on difference



Switch-on difference of secondary loop

Adjust the switch-on difference

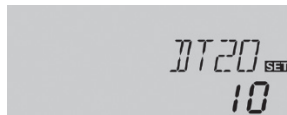

Switch-off difference

Adjust the switch-off difference

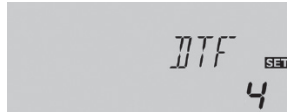

Target temperature

Adjust the target temperature



Completing the commissioning menu

After the last channel of the commissioning menu has been adjusted and confirmed, the controller asks for confirmation of the adjustments.

To confirm the adjustments made in the commissioning menu, press button 3



The controller is now ready for operation with typical settings to suit the system layout

The settings made in the commissioning menu can be changed later on in the corresponding adjustment channels. Additional functions and options can be individually set by accessing the system adjustment channels.

Display Channels:

COL:

Collector Temperature
Display range: -40 to +482 °F



Shows the current collector temperature.

TST:

Tank temperature
Display range: -40 to +500 °F

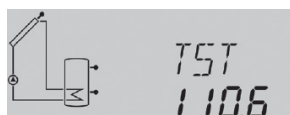

Shows the current tank temperature (from tank bottom sensor).

TPRI:

Flow temperature of the primary loop
Display range -40 to +500 °F



Indicates the current flow temperature of the primary loop in the Solex station.

TSEC:

Flow temperature of the secondary loop
Display range -40 to +500 °F

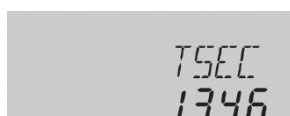

Indicates the current flow temperature of the secondary loop in the Solex station.

n1%, n2%:

Current pump speed
Display range 30 to 100%



Indicates the current pump speed of the corresponding pump:

- n1%: current pump speed pump 1 – primary loop
- n2%: current pump speed pump 2 – secondary loop

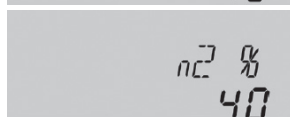

h P1, h P2

Operating hours counter
Display channel

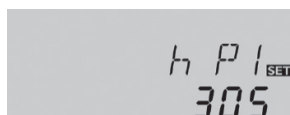

The operating hours counter adds up the solar operating hours of the respective relay (h P1, h P2). Full hours are shown on the display.

The total operating hours can be reset. When the operating hours channel is selected the symbol **SET** is permanently shown in the display. The set button (3) must be pressed for approximately 2 seconds in order to go into the reset mode for the counter. The display symbol **SET** will be flashing and the operating hours will be set to 0. In order to finish the reset procedure the set button (3) must be pressed in order to confirm.

In order to interrupt the reset procedure no button should be pressed for about 5 seconds. The controller will automatically return to the indication mode with the previous total.

kWh/MWh:

Heat quantity value shown in the kWh and MWh display channels. The sum of both channels form the total heat output.



The total heat quantity value can be reset. When one of the heat quantity display channels is selected the symbol **SET** is permanently shown in the display. The set button (3) must be pressed for approximately 2 seconds in order to go into the reset mode for the counter. The display symbol **SET** will be flashing and the value for heat quantity will be set to 0. In order to finish the reset procedure the set button (3) must be pressed in order to confirm.

TIME:

Current time based on 24 hour clock, e.g. 15:00 = 3 pm

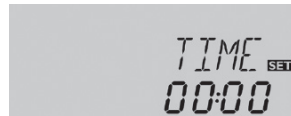

In order to interrupt the reset procedure no button should be pressed for about 5 seconds. The controller will automatically return to the indication mode with the previous total.

To set the current time:

Press button 3 for two seconds to adjust the hours

Set the hours by pressing buttons 1 and 2

Press button 3 again to set the minutes

Set the minutes by pressing buttons 1 and 2

Press button 3 in order to save the adjustments

Once the final display channel is reached the remaining system setting channels may only be accessed by holding the forward (2) button down for approximately 2 seconds. The following setting channels will then be shown:

Adjustment channels:**DT10 / DT20:**

Switch-on temperature diff.
Adjustment range
2.0 to 40.0 °F

Recommended setting: 10.0

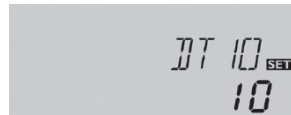

The controller works as a standard differential controller. It calculates the temperature difference between the collector sensor S1 and the tank temperature sensor S3. If this temperature difference reaches the switch-on temperature difference DT10, the primary loop pump is switched on. If the temperature difference falls below the switch-off difference DTF, the pump is switched off.

DT F:

Switch-off temperature diff.
Adjustment range
1.0 to 39.0 °F

Recommended setting: 4.0

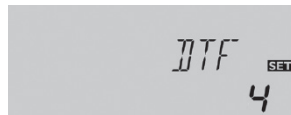

If the switch-on temperature difference between the upper heat exchanger sensor S4 and the tank temperature sensor S3 is reached (DT20), the secondary loop pump will be switched on.

TMN:

Minimum runtime
Adjustment range
1 to 10 min

Recommended setting: 2 min



Solar loading will be carried out for the adjustable minimum runtime TMN during which the switch-off condition will be ignored to stabilize the system.

If the temperature difference between the upper heat exchanger sensor S4 and the lower heat exchanger temperature sensor S2 falls below the switch-off temperature difference DTF both loops will be switched off.

Note: The switch-on temperature difference must be at least 1° higher than the switch-off temperature difference.

TAR:

Pump speed control target temperature

Adjustment range
70 to 210 °F in steps of 2 °F

Recommended setting: 130 °F



The primary and secondary pump speeds are controlled based on the target temperature of the upper heat exchanger sensor S4.

The primary and secondary loop pumps will run at minimum speed until the target temperature at S4 is reached. If the target temperature is exceeded by 5°, the speed of the primary loop pump will increase by one step (10%). This state will be held for 2 min even if the sensor temperature decreases. If, during this time, the S4 temperature increases by more than 5°, the pump speed of the secondary pump will also increase by 1 step.

This state will be held for 2 min each time the pumps increase a step unless the temperature increases further by 5° and the speed is increased another step. If the temperature decreases the secondary pump will decrease by 1 step followed by the primary pump.

n1MN, n2MN:

Minimum pump speed
Adjustment range
30 to 100%

Recommended setting: 40%

**S MX:**

Maximum tank temperature
Adjustment range:
100 to 160 °F

Recommended setting: 160 °F



A relative minimum pump speed that can be allocated to the outputs R1 (primary pump) and R2 (secondary pump) via the adjustment channels n1MN and n2MN.

If the maximum tank temperature is reached the control will prevent the pump from operating and heating the tank any further. A fixed hysteresis of 4 °F is set for the maximum tank temperature.

When the maximum tank temperature setting is reached the ☀ symbol will be shown on the display.

EM:

Collector temperature limit
Adjustment range:
170 to 390 °F

Recommended setting: 260 °F



If the collector temperature limit is reached the solar pump (R1) is deactivated in order to avoid damaging overheating of the solar components (collector emergency shutdown). A hysteresis of 20 °F is set for the collector temperature limit.

If the collector temperature limit setting is exceeded the ⚠ symbol will be shown flashing on the display.

OCN:

Minimum collector limit
Adjustment: OFF / ON

Recommended setting: OFF



The minimum collector temperature is a minimum switching temperature, which must be exceeded before the solar pump (R1) is switched on. The minimum temperature will avoid short cycling of the solar pump at low collector temperatures. If the collector temperature is lower than the minimum collector temperature set point the ❄ symbol will be shown flashing on the display.

CMN:

Minimum collector temp.
Adjustment range:
50 to 195 °F

Recommended setting: 50 °F

Channel only available when OCN is active



This function is unnecessary if the system backup heating element has a set point maintained at 120 °F.

OCF:

Antifreeze function
Adjustment: OFF / ON

Recommended setting: OFF



This function is used to transfer heat from the storage tank to the collector in order to avoid freezing of the heat transfer medium in some system types.

Note: Since this function uses the limited heat quantity of the tank, the antifreeze function should only be used in regions with a few days of temperature around the freezing point. The antifreeze function will be suppressed if the tank temperature falls below 40 °F in order to protect the tank from frost damage.

If the system uses a 50/50 solution of propylene glycol and water it is freeze resistant to -30 °F; therefore, this function is not necessary.

There is an automatic antifreeze function for the heat exchanger that activates R2 (100%) if the heat exchanger temperature falls below 40 °F.

CFRO:

Antifreeze temperature on
Adjustment range:
38 to 48 °F

Recommended setting: 39 °F

Channel only available when OCF is active

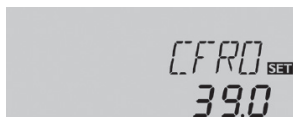
**CFRF:**

Antifreeze temperature off
Adjustment range:
40 to 50 °F

Recommended setting: 41 °F

Channel only available when OCF is active



O TC:

Tube collector function

Adjustment: OFF / ON

Recommended setting: OFF

The tube collector function is only needed for systems that use vacuum tube solar collectors.

This function is not necessary for this system.

OHQM:

Heat quantity measurement

Adjustment: OFF / ON

Recommended setting: OFF

If enabled a heat quantity measurement is possible for this system in conjunction with the flow meter.

FMAX:

Volume flow in gal/min

Adjustment range:

1.0 to 10.0 gal/min in steps of 0.2 gal/min

Recommended setting: pump station flow meter reading.

Channel only available when OHQM is active



For OHQM to give an accurate reading the volume flow readable at the flowmeter (gal/min) must be adjusted in the channel FMAX.

MEDT:

Type of antifreeze

Adjustment range: 0 to 3

Recommended setting: 1

Channel only available when OHQM is active.



For OHQM to give an accurate reading the type of heat transfer fluid type(antifreeze) must be set in the channel MEDT:

0: water

1: propylene glycol

2: ethylene glycol

3: Tyfocor ® LS / G – LS

Caution: for this system type only type 1: propylene glycol should be selected. Use of any other type of heat transfer fluid in this system may cause damage to the system or present a health hazard

MED%:

Concentration of antifreeze by volume %

Adjustment range: 20 to 70%

Recommended setting: 50

Channel only available when OHQM is active.



The antifreeze concentration by % volume should be entered in this channel for OHQM to give an accurate reading.

Standard system concentration should be a 50% propylene glycol and 50% distilled or de-mineralized water.

MAN1:

Operating mode R1

Adjustment range:

OFF / AUTO / ON / n1LO

**MAN2:**

Operating mode R2

Adjustment range:

OFF / AUTO / ON / n2LO



For system setup and service work the operating mode of the pump can be manually adjusted by selecting the adjustment value for MAN1, MAN2 as follows:

Operating mode:

OFF: relay off Δ (flashing) + ☺

AUTO: relay in automatic operation

ON: relay on Δ (flashing) + ☺ + ①/②

n1(2)LO: minimum speed

Note: Always adjust the operating mode back to “Auto” when the control and service work is completed. Normal operation is not possible in manual mode.

UNIT:

Temperature units

Adjustment: FAH, CEL

Recommended setting: FAH

The temperature unit can be adjusted in this channel:

FAH: °Fahrenheit

CEL: °Celsius

RESE:

System reset



If the reset is selected, the controller will revert back to the factory settings and the commissioning assistant will be displayed for new start-up.

The final channel indicates the current version number for the controller. To exit out of the system setting mode press the backward button (2) repeatedly until you reach the first display channel (COL).

TROUBLESHOOTING

PROBLEM	CHECK THIS	POSSIBLE CAUSE	CORRECTIVE ACTION
No hot water	Storage water heater	No power to auxiliary back-up heating element	Check high temperature protection and push reset button on the heater thermostat. (Use caution when dealing with electricity.)
	Storage water heater thermostat	Thermostat defective	Replace
	Thermostatic mixing valve	Improper adjustment	Check water temperature at house faucet and adjust valve setting
		Valve defective	Replace. System must not be run without thermostatic mixing valve due to scald risk.
Not enough hot water	Storage water heater	Undersized for hot water demand load	Replace
		Thermostat set too low	Increase set point temperature
		Element failure	Replace element
		Thermostat failure	Replace thermostat
		Element disconnected	Reconnect element and set thermostat to 120°F (49 °C)
	Check valve	Heat loss due to defective check valve in solar pump station	Inspect valve and repair or replace
	Cold water supply dip tube	Missing or defective	Replace dip tube
	Collectors	Absorber coating degradation	Replace collector
		Collector panel area undersized	Increase collector area
		Excessive condensation	Inspect and clean weep holes and vents at bottom.
		Glazing dirty	Clean as required
		Leaks	Repair
		Orientation	Check orientation. Face collector within 45° of due South
		Shaded by tree(s) or other obstructions	Remove obstacle and shading or relocate collectors
		Improper tilt	Check tilt for geographic area. Ensure tilt is equal to latitude plus 15°
	Improperly plumbed	Compare with system schematic and correct.	
	Differential Controller	Improper operation (cycling, late turn on)	Check sensor placement and insulation from ambient conditions
		Faulty sensor ⚠ + 🔧 is shown and control reads 888.8 instead of temperature	Sensor line break. Check the line and repair or replace
		Faulty sensor ⚠ + 🔧 is shown and control reads -88.8 instead of temperature	Short circuit. Check the line for breaks, metal contact, water exposure and corrosion.

PROBLEM	CHECK THIS	POSSIBLE CAUSE	CORRECTIVE ACTION
Not enough hot water (cont.)	Differential Controller	Improper wiring or loose connections)	Compare with system schematic. Check for proper connections. Seal all splices against moisture
	Isolation valves	Closed	Open
	Thermostatic mixing valve	Improper adjustment	Check water temperature at house faucet and adjust valve setting
		Valve defective	Replace. System must not be run without thermostatic mixing valve due to scald risk.
	Piping	Insufficient Insulation	Add insulation where required
		High heat losses	Check insulation for splits, deterioration, absence
		Nighttime thermosyphoning	Check for pump operation at night
		Improperly plumbed	Compare with system schematic. Check flow direction
		Flow blockage	Flush system. Check effluent for debris.
		Low system pressure	Check pressure gauge. Set system pressure to correct setting, check for leaks.
	Pump	No power	Check breaker, pump cord, and controller fuse. Repair or replace
		Flow rated too high or too low	Adjust flow rate
		Faulty pump	Listen for irregular noises in pump operation. Feel collector feed and return line for temperature difference. Ensure all air is purged from system.
	Runs continuously	Check sensors for shorts	
No hot water in the morning	Storage water heater	Circuit breaker shut off	Turn breaker on
	Differential controller	Sensor wires reversed	Ensure the collector and tanks sensors are wired to the correct position on the controller
Water too hot	Thermostatic mixing valve	Improper adjustment	Check water temperature at house faucet and adjust valve setting
		Valve defective	Replace. System must not be run without thermostatic mixing valve due to scald risk.
No water	Cold-water supply valve	Valve closed	Open valve
Pump does not start	Differential controller	Controller set to "off" position	Set system operation to "Auto"
		Unplugged	Return power to controller
		On and/or off temperature differential set points too high	Reset on and off differentials according to recommendations
		Loose contacts	Clean contacts and tighten connections or replace
		Blown fuse	Replace fuse

PROBLEM	CHECK THIS	POSSIBLE CAUSE	CORRECTIVE ACTION
Pump does not start	Electrical power supply	Controller plug disconnected	Reconnect control plug to power outlet
		Blown fuse or breaker tripped on overload	Determine cause and replace fuse or reset breaker
	Pump	Motor failure	Replace pump
	Sensors	Defective sensors, sensor error	Check wiring continuity. Repair or replace
Pump starts, but cycles continuously	Differential controller	On and/or off temperature differential set points too low	Reset on and off differentials according to recommendations
	Piping	Reversed connections to collectors	Compare with system schematic and reconnect properly
	Sensors	Improper location	Compare with system schematic and reconnect properly
Pump cycles after dark	Differential controller	Recooling function active and max temperature setting exceeded	Controller operating properly. No fault.
	Sensors	Defective sensors, sensor error	Check wiring continuity. Repair or replace
Pump runs continuously	Differential controller	Off temperature differential set too low	Reset off differential according to recommendation
		Controller set to "on" position	Set system operation to "Auto"
Pump operated but no fluid flows from collectors	Air Scoop	System air-locked	Purge air from air scoop in solar pump station by opening valve slowly. Caution: after air is evacuated fluid will flow out in a small stream and may be hot. Cover port with a rag to catch any fluid.
	Air vent	System air-locked	Open air vent on the top of the system and purge excess air. Close after purging.
	Fluid	Loss of fluid from system	Locate leak and repair
	Isolation valves	Valves in closed position	Open valves
	Piping	Clogged or damaged piping	Unblock piping or repair damaged piping
	Pump	Broken impeller shaft	Replace shaft
		Not vented properly	Install in correct orientation
	Undersized	System piping run too long. Refer to maximum piping lengths and adjust	
Noisy system	Air vents	Air trapped in system	Open air vent and purge air scoop in solar pump station by opening the valve slowly. Caution: after air is evacuated fluid will flow out in a small stream and may be hot. Cover port with a rag to catch any fluid.
	Pump	Bearings are dry or have excessive wear	Lubricate or replace
		Impeller loose	Tighten or replace impeller

SYSTEM MAINTENANCE

SYSTEM CHECKPOINT

To check system: temperature, pressure and flow conditions, reference Figure 19 thru Figure 22 on page 22.

- Components C & D: Provide system temperature.
- Component I: Provides system pressure.
- Component K: Provides flow information.
- Component B: Provides an overall digital read-out of the system. Reference Pump Station Control Instructions for detailed information on the Operation and Function of the Pump Station Control.

HEAT TRANSFER FLUID (HTF) QUALITY

The chemical composition of the HTF may change over time. The HTF quality should be monitored on a periodic basis – at least annually. After summer and before any chance of the first freeze is an ideal time. A drop in pH can indicate the system has been stagnating frequently. The cause should be determined and corrected.

To test the pH level, use a digital pH tester or tight range litmus paper. Remove a small sample of the fluid from the air scoop on the pump station. The pH should be between 8.1 and 12.0. Fluid with pH between 7.5 and 8.1 can be conditioned by your contractor using an inhibitor boost. Fluid with pH above 12.0 or that is dark, dirty or has an acidic smell should be replaced.

PIPING AND EXTERNAL INSULATION

Annually, all piping should be checked for leakage at joints, and unions. Any damaged external insulation should be repaired or replaced.

WIRING AND CONNECTIONS

Annually, check wiring and connections, including sensor wiring and splices. Look for signs of overheating, discoloration, corrosion or loose connections. Any damaged wiring should be repaired or replaced.

FLUID LEAKS

If you detect a glycol or water leak, or the glycol loop pressure drops unexpectedly, contact your installation contractor immediately to diagnose the problem and recharge the system.

SOLAR PANEL CLARITY

If you live in a dusty climate, once a month wash off dirt that settles on the solar panel glass. Clean glass allows the solar panel to maintain a high level of thermal performance.

EXPANSION TANK

Annually check condition of the solar expansion tank. Check to see if it is waterlogged by quickly pressing Schrader valve stem at bottom of the tank. You should get a quick burst of air. If fluid is discharged, the tank may be waterlogged and need replacement. Contact a qualified solar installer if the tank needs replacement.

VACATION

For extended periods with no hot water usage such as vacation it is recommend that the power to the pump station be disconnected and that the solar collectors are covered with a blanket or other means to prevent heat gain from the sun to prevent system overheating and breakdown of the glycol solution.

EMERGENCY SHUTDOWN

For a Emergency system shut down both the power to the unit and the pump station shall be disconnected. In addition the pump station has two ball valves located as shown below that must be turned to the 90° position to shut off the flow through the collector loop. See Figure 37. The inlet water shut-off to the unit itself shall also be closed. This will isolate any electricity or fluids from entering the unit.

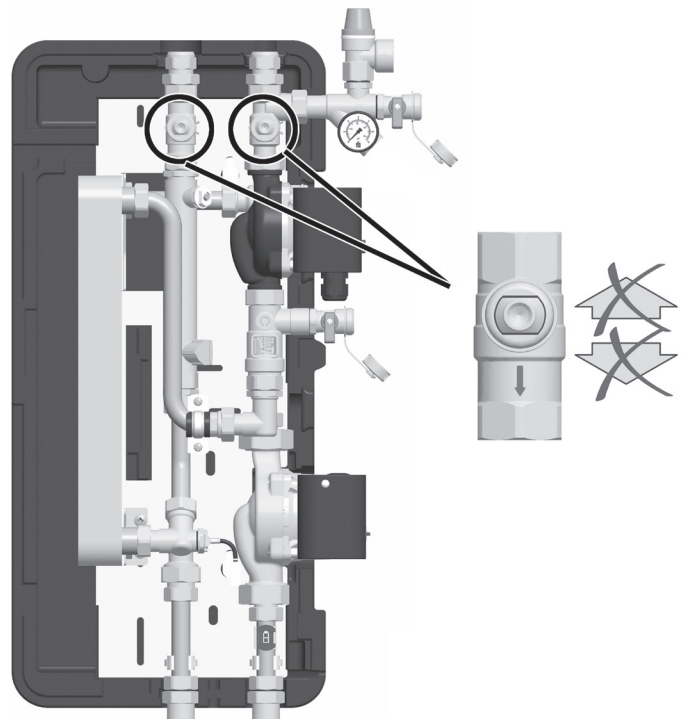

Figure 37.

REPAIR PARTS

REPAIR PARTS SCHEDULE

ORDERING REPAIR PARTS

The following parts may be ordered through the store or dealer from whom you purchased the solar water heater, or direct from the factory listed on the model & rating plate located on the lower front of the solar water heater and by phone at 1-800-433-2545. Selling prices will be furnished on request or parts will be shipped at prevailing prices and you will be billed accordingly. When ordering repair parts always give the following information: (1) Part description, (2) Model & Serial number, (3) Part number.

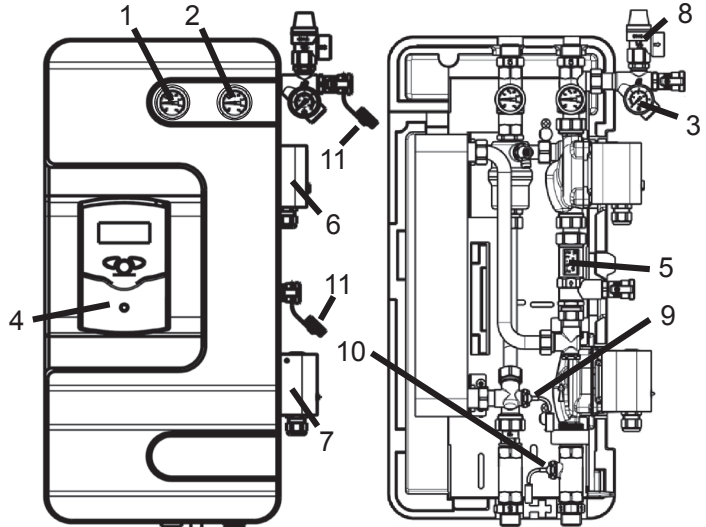
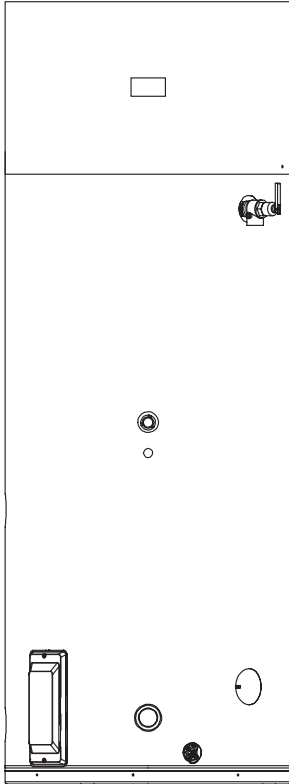

Refer to the manual and parts list provided with the solar storage tank for its serviceable parts.

ITEM	PART DESCRIPTION	SERVICE PART #
SOLEX DWHX PUMP STATION SERVICE PARTS		
1	Temperature Gauge-Supply (Red)	9007789005
2	Temperature Gauge-Return (Blue)	9007788005
3	Pressure Gauge	9007454005
4	Resol BS Solex US Controller	9007785005
5	Solex Flowmeter	9007782005
6	Wilo Star S 21U-15 Primary Pump	9007783005
7	Wilo Star S 21BU Secondary Pump	9007784005
8	Pressure Relief Valve	9007460005
9	Temperature Sensor (Plug-In)	9007786015
10	Temperature Sensor (Screw-In)	9007787015
11	Sealing Cap	9007792015
12	Solex Gasket Kit (Not Pictured)	9007793015

ITEM	PART DESCRIPTION	SERVICE PART #
MISCELLANEOUS SYSTEM SERVICE PARTS		
13	Armaceil UT/SolaFlex Pipe Insulation 1/2" X 6" (Not Pictured)	318002-000
14	Armaceil UT/SolaFlex Pipe Insulation 1" x 6' (Not Pictured)	318002-002
15	Chromagen CR110 AP Solar Collector (Not Pictured)	9910010000
16	Chromagen CR130 AP Solar Collector (Not Pictured)	9910012000
17	Chromagen CR140 AP Solar Collector (Not Pictured)	9910014000
18	Water Tempering (Mixing) Valve (Not Pictured)	9008355005
19	Temperature Sensor Control Wire Assy 75' Roll (Not Pictured)	9910051000
20	Propylene Glycol HTF (DOWFROST) 5 Gallon (Not Pictured)	9910055000
21	Air Vent (Not Pictured)	9007451005
22	Solar Loop Expansion Tank - 2 Gallons(Not Pictured)	9910054000
23	Solar Loop Expansion Tank - 4.5 Gallons(Not Pictured)	9910104000
24	1/2" Copper Roof Flashing w/Cap (Not Pictured)	9910049000
25	1/2" Copper Roof Flashing w/Cap & Gooseneck (Not Pictured)	9910050000
26	Collector Temperature Sensor (Not Pictured)	9007461015
27	Tank Temperature Sensor (Not Pictured)	9007462015

Fill in the following for your own reference. The model and serial number are found on the solar system's rating plate located on the pump station.

Date Installed _____ Model No. _____ Serial No. _____ Installers Name _____
 Phone No. _____ Installers Address: _____ City and State _____ Zip Code _____

DOWFROST HEAT TRANSFER FLUID PROPERTIES

Potential Health Effects

Eye Contact: May cause slight temporary eye irritation. Corneal injury is unlikely.

Skin Contact: Prolonged contact is essentially nonirritating to skin. Repeated contact may cause flaking and softening of skin.

Skin Absorption: Prolonged skin contact is unlikely to result in absorption of harmful amounts.

Inhalation: At room temperature, exposure to vapor is minimal due to low volatility. Mist may cause irritation of upper respiratory tract (nose and throat).

Ingestion: Very low toxicity if swallowed. Harmful effects not anticipated from swallowing small amounts.

Effects of Repeated Exposure: In rare cases, repeated excessive exposure to propylene glycol may cause central nervous system effects.

Component	CAS	# Amount
Propylene glycol	57-55-6	> 95.0 %
Dipotassium hydrogen phosphate	7758-11-4	< 3.0 %
Deionized water	7732-18-5	< 3.0 %

First-aid measures

Eye Contact: Flush eyes thoroughly with water for several minutes. Remove contact lenses after the initial 1-2 minutes and continue flushing for several additional minutes. If effects occur, consult a physician, preferably an ophthalmologist.

Skin Contact: Wash skin with plenty of water.

Inhalation: Move person to fresh air; if effects occur, consult a physician.

Ingestion: No emergency medical treatment necessary.

Notes to Physician: No specific antidote. Treatment of exposure should be directed at the control of symptoms and the clinical condition of the patient.

Accidental Release Measures

Steps to be Taken if Material is Released or Spilled: Small spills: Absorb with materials such as: Cat litter. Sawdust. Vermiculite. Zorb-all®. Collect in suitable and properly labeled containers. Large spills: Dike area to contain spill. Recover spilled material if possible.

Handling and Storage

Handling

General Handling: No special precautions required. Keep container closed. Spills of these organic materials on hot fibrous insulations may lead to lowering of the autoignition temperatures possibly resulting in spontaneous combustion. See Section 8, EXPOSURE CONTROLS AND PERSONAL PROTECTION.

Storage

Do not store in: Galvanized steel. Opened or unlabeled containers. Store in original unopened container.

Exposure Controls / Personal Protection

Exposure Limits

Component List Type Value

Propylene glycol

Personal Protection

Eye/Face Protection: Use safety glasses.

Skin Protection: Wear clean, body-covering clothing.

Hand protection: Use gloves chemically resistant to this material when prolonged or frequently repeated contact could occur. Examples of preferred glove barrier materials include: Butyl rubber. Natural rubber ("latex"). Neoprene. Nitrile/butadiene rubber ("nitrile" or "NBR").

Respiratory Protection: Respiratory protection should be worn when there is a potential to exceed the exposure limit requirements or guidelines. If there are no applicable exposure limit requirements or guidelines, wear respiratory protection when adverse effects, such as respiratory irritation or discomfort have been experienced, or where indicated by your risk assessment process.

Physical and Chemical Properties

Physical State Liquid

Color Colorless

Odor Characteristic

Flash Point - Closed Cup 104 °C (219 °F) Pinsky-Martens Closed Cup ASTM D 93 (based on major component), Propylene glycol

Flammable Limits In Air Lower: 2.6 %(V) Literature Propylene glycol

Upper: 12.5 %(V) Literature Propylene glycol

Autoignition Temperature 371 °C (700 °F) Literature Propylene glycol

Vapor Pressure 2.2 mmHg Literature

Boiling Point (760 mmHg) 152 °C (306 °F) Literature .

Vapor Density (air = 1) >1.0 Literature

Specific Gravity (H₂O = 1) 1.05 20 °C/20 °C Literature

Freezing Point supercools

Melting Point Not applicable to liquids

Solubility in Water (by weight)

100 % Literature

pH 10.0 Literature

Kinematic Viscosity 43.4 cSt @ 20 °C Literature

Disposal Considerations

DO NOT DUMP INTO ANY SEWERS, ON THE GROUND, OR INTO ANY BODY OF WATER. All disposal practices must be in compliance with all Federal, State/Provincial and local laws and regulations. Regulations may vary in different locations. Waste characterizations and compliance with applicable laws are the responsibility solely of the waste generator.

Regulatory Information

OSHA Hazard Communication Standard

This product is not a "Hazardous Chemical" as defined by the OSHA Hazard Communication Standard, 29 CFR 1910.1200.

Superfund Amendments and Reauthorization Act of 1986 Title III (Emergency Planning and Community Right-to-Know Act of 1986) Sections 311 and 312

Immediate (Acute) Health Hazard	No
Delayed (Chronic) Health Hazard	No
Fire Hazard	No
Reactive Hazard	No
Sudden Release of Pressure Hazard	No

NOTES

NOTES

