



**GAS-FIRED COMMERCIAL
COPPER BOILERS FOR HYDRONIC HEATING
AND HOT WATER SUPPLY**



**User's Information Manual
GB/GW MODELS:
1000, 1300, 1500, 1850, 2100, 2500
SERIES: 500, 501, 502, 503, 504, 505**

WARNING: If the information in this manual is not followed exactly, a fire or explosion may result causing property damage, personal injury or loss of life.

- Do not store or use gasoline or other flammable vapors and liquids in the vicinity of this or any other appliance.

WHAT TO DO IF YOU SMELL GAS:

- Extinguish any open flame.
- Do not try to light any appliance.
- Do not touch any electrical switch; do not use any phone in your building.
- Immediately call your gas supplier from a neighbor's phone. Follow the gas supplier's instructions.
- If you cannot reach your gas supplier, call the fire department.
- Installation and service must be performed by a qualified installer, service agency or the gas supplier.

⚠ WARNING

SHOULD OVERHEATING OCCUR OR THE GAS SUPPLY FAIL TO SHUT OFF, DO NOT TURN OFF OR DISCONNECT THE ELECTRICAL SUPPLY TO THE PUMP. INSTEAD, SHUT OFF THE GAS SUPPLY AT A LOCATION EXTERNAL TO THE APPLIANCE.

⚠ WARNING

DO NOT USE THIS BOILER IF ANY PART HAS BEEN UNDER WATER. IMMEDIATELY CALL A QUALIFIED SERVICE TECHNICIAN TO INSPECT THE BOILER AND TO REPLACE ANY PART OF THE CONTROL SYSTEM AND ANY GAS CONTROL WHICH HAS BEEN UNDER WATER.

LIGHTING INSTRUCTIONS

These models have an automatic hot surface ignition system mounted on the combustion chamber panel inside the front jacket. This hot surface igniter ignites the main burner gas whenever the system control calls for heat.

Before proceeding with operation of the unit, make sure the boiler and system are filled with water and all air is expelled from the boiler, radiator tank(s) and piping.

⚠ WARNING

THE MAIN MANUAL GAS SHUT-OFF VALVE MUST HAVE BEEN CLOSED FOR AT LEAST FIVE (5) MINUTES BEFORE LIGHTING. THIS WAITING PERIOD IS AN IMPORTANT SAFETY STEP. ITS PURPOSE IS TO PERMIT GAS THAT MIGHT HAVE ACCUMULATED IN THE COMBUSTION CHAMBER TO CLEAR. IF YOU DETECT GAS AT THE END OF THE PERIOD DO NOT PROCEED WITH LIGHTING. RECOGNIZE THAT GAS ODOR, EVEN IF IT SEEMS WEAK, MAY INDICATE PRESENCE OF ACCUMULATED GAS SOME PLACE IN THE AREA WITH A RISK OF FIRE OR EXPLOSION.

⚠ WARNING

THERE IS A RISK IN USING FUEL BURNING APPLIANCES SUCH AS GAS WATER BOILERS IN ROOMS, GARAGES OR OTHER AREAS WHERE GASOLINE AND OTHER FLAMMABLE LIQUIDS ARE USED OR STORED, OR ENGINE-DRIVEN EQUIPMENT OR VEHICLES ARE STORED, OPERATED OR REPAIRED. FLAMMABLE VAPORS ARE HEAVY AND TRAVEL ALONG THE FLOOR AND MAY BE IGNITED BY THE BOILER'S MAIN BURNER FLAMES CAUSING FIRE OR EXPLOSION. SOME LOCAL CODES PERMIT OPERATION OF GAS APPLIANCES IF INSTALLED 18 INCHES OR MORE ABOVE THE FLOOR. THIS MAY REDUCE THE RISK IF LOCATION IN SUCH AN AREA CANNOT BE AVOIDED.

INDEX	PAGE
GENERAL	1
LIGHTING INSTRUCTIONS	2 - 3
OPERATING SEQUENCE, IGNITION CONTROLS INFORMATION	4 - 18
TROUBLESHOOTING & MAINTENANCE	19 - 23
WARRANTY	24

25589 Highway 1, McBee, SC 29101
www.hotwater.com

PLEASE KEEP THESE INSTRUCTIONS ADJACENT TO BOILER AND
NOTIFY OWNER TO KEEP FOR FUTURE REFERENCE

FOR YOUR SAFETY READ BEFORE OPERATING



WARNING: If you do not follow these instructions exactly, a fire or explosion may result causing property damage, personal injury or loss of life.



- A. THIS APPLIANCE DOES NOT HAVE A PILOT. IT IS EQUIPPED WITH AN IGNITION DEVICE WHICH AUTOMATICALLY LIGHTS THE BURNER. DO NOT TRY TO LIGHT THE BURNER BY HAND.
- B. **BEFORE LIGHTING:** SMELL ALL AROUND THE APPLIANCE AREA FOR GAS. BE SURE TO SMELL NEXT TO THE FLOOR BECAUSE SOME GAS IS HEAVIER THAN AIR AND WILL SETTLE ON THE FLOOR.

WHAT TO DO IF YOU SMELL GAS

- DO NOT TRY TO LIGHT ANY APPLIANCE.
- DO NOT TOUCH ANY ELECTRIC SWITCH; DO NOT USE ANY PHONE IN YOUR BUILDING
- IMMEDIATELY CALL YOUR GAS SUPPLIER FROM A NEIGHBOR'S PHONE. FOLLOW THE GAS SUPPLIER'S INSTRUCTIONS.
- IF YOU CANNOT REACH YOUR GAS SUPPLIER, CALL THE FIRE DEPARTMENT.

- C. USE ONLY YOUR HAND TO TURN THE GAS CONTROL KNOB. NEVER USE TOOLS. IF THE KNOB WILL NOT TURN BY HAND, DON'T TRY TO REPAIR IT. CALL A QUALIFIED SERVICE TECHNICIAN. FORCE OR ATTEMPTED REPAIR MAY RESULT IN A FIRE OR EXPLOSION.
- D. DO NOT USE THIS APPLIANCE IF ANY PART HAS BEEN UNDER WATER. IMMEDIATELY CALL A QUALIFIED SERVICE TECHNICIAN TO INSPECT THE APPLIANCE AND TO REPLACE ANY PART OF THE CONTROL SYSTEM AND ANY GAS CONTROL WHICH HAS BEEN UNDER WATER.
- E. DO NOT OPERATE APPLIANCE UNLESS UNIT IS FILLED WITH WATER AND WATER LINES ARE FULLY OPEN.

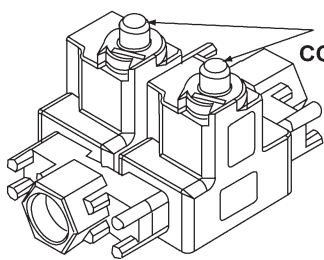

GAS VALVE CONTROL KNOB

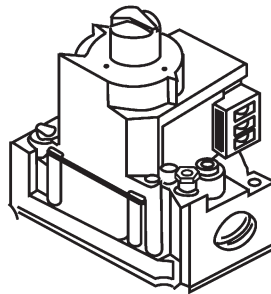

HONEYWELL DOUBLE GAS VALVE HONEYWELL SINGLE GAS VALVE

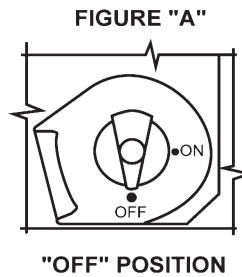

"OFF" POSITION

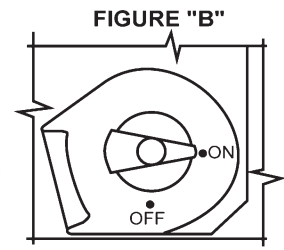

"ON" POSITION

OPERATING INSTRUCTIONS

1. STOP! READ THE SAFETY INFORMATION ABOVE ON THIS LABEL.
2. SET THE SYSTEM CONTROLLER TO THE LOWEST SETTING.
3. TURN OFF ALL ELECTRIC POWER TO APPLIANCE.
4. THIS APPLIANCE IS EQUIPPED WITH AN IGNITION DEVICE WHICH AUTOMATICALLY LIGHTS THE BURNER. DO NOT TRY TO LIGHT THE BURNER BY HAND.
5. REMOVE CONTROL ACCESS PANEL.
6. REFER TO DIAGRAMS ABOVE. TURN TOP KNOB OF GAS CONTROL CLOCKWISE TO "OFF" POSITION. (FIG. A)
7. WAIT FIVE (5) MINUTES TO CLEAR OUT ANY GAS. THEN SMELL FOR GAS, INCLUDING NEAR THE FLOOR. IF YOU SMELL GAS, STOP! FOLLOW "B" IN THE SAFETY INFORMATION ABOVE ON THIS LABEL. IF YOU DON'T SMELL GAS, GO TO THE NEXT STEP.
8. TURN TOP KNOB OF GAS CONTROL COUNTER-CLOCKWISE TO "ON" POSITION. (FIG. B).
9. REPLACE CONTROL ACCESS PANEL.
10. TURN POWER SWITCH TO "ON" POSITION (SWITCH LIGHT COMES ON).
11. SET THE SYSTEM CONTROLLER TO DESIRED SETTING.
12. IF THE APPLIANCE WILL NOT OPERATE, FOLLOW THE INSTRUCTIONS "TO TURN OFF GAS TO THE APPLIANCE" AND CALL YOUR SERVICE TECHNICIAN OR GAS SUPPLIER.

TO TURN OFF GAS TO APPLIANCE

1. SET THE SYSTEM CONTROLLER TO THE LOWEST SETTING.
2. TURN POWER SWITCH ON APPLIANCE TO "OFF" POSITION (SWITCH LIGHT GOES OUT).
3. REMOVE ACCESS PANEL TO EXPOSE GAS CONTROL.
4. REFER TO DIAGRAMS ABOVE. TURN TOP KNOB OF GAS CONTROL CLOCKWISE TO "OFF" POSITION, (FIG. A).
5. REPLACE CONTROL ACCESS PANEL.

FOR YOUR SAFETY READ BEFORE OPERATING



WARNING: IF YOU DO NOT FOLLOW THESE INSTRUCTIONS EXACTLY, A FIRE OR EXPLOSION MAY RESULT CAUSING PROPERTY DAMAGE, PERSONAL INJURY OR LOSS OF LIFE.



- A. THIS APPLIANCE DOES NOT HAVE A PILOT. IT IS EQUIPPED WITH AN IGNITION DEVICE WHICH AUTOMATICALLY LIGHTS THE BURNER. DO NOT TRY TO LIGHT THE BURNER BY HAND.
- B. BEFORE OPERATING: SMELL ALL AROUND THE APPLIANCE AREA FOR GAS. BE SURE TO SMELL NEXT TO THE FLOOR BECAUSE SOME GAS IS HEAVIER THAN AIR AND WILL SETTLE ON THE FLOOR.

WHAT TO DO IF YOU SMELL GAS:

- DO NOT TRY TO LIGHT ANY APPLIANCE.
 - DO NOT TOUCH ANY ELECTRIC SWITCH.
 - DO NOT USE ANY PHONE IN YOUR BUILDING.
 - IMMEDIATELY CALL YOUR GAS SUPPLIER FROM A NEIGHBOR'S PHONE. FOLLOW THE GAS SUPPLIER'S INSTRUCTIONS.
- C. IF YOU CANNOT REACH YOUR GAS SUPPLIER, CALL THE FIRE DEPARTMENT.
- C. USE ONLY YOUR HAND TO TURN THE MAIN MANUAL GAS VALVE HANDLE. NEVER USE TOOLS. IF THE HANDLE WILL NOT TURN BY HAND, DON'T TRY TO REPAIR IT. CALL A QUALIFIED SERVICE TECHNICIAN. FORCE OR ATTEMPTED REPAIR MAY RESULT IN A FIRE OR EXPLOSION.
- D. DO NOT USE THIS APPLIANCE IF ANY PART HAS BEEN UNDER WATER. IMMEDIATELY CALL A QUALIFIED SERVICE TECHNICIAN TO INSPECT THE APPLIANCE AND TO REPLACE ANY PART OF THE CONTROL SYSTEM AND ANY GAS CONTROL WHICH HAS BEEN UNDER WATER.
- E. DO NOT OPERATE APPLIANCE UNLESS UNIT IS FILLED WITH WATER AND WATER LINES ARE FULLY OPEN.

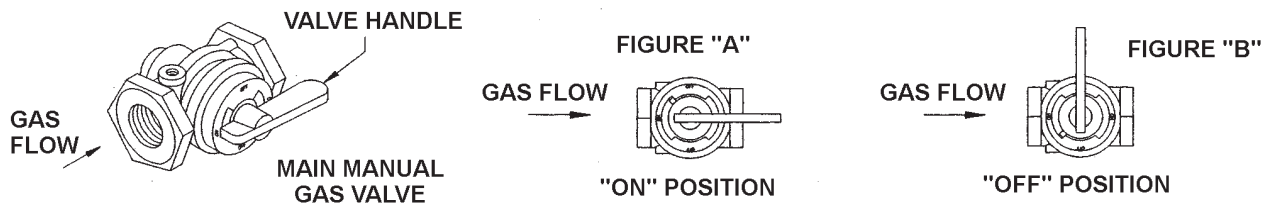

OPERATING INSTRUCTIONS

1. STOP! READ THE SAFETY INFORMATION ABOVE ON THIS LABEL.
2. SET THE SYSTEM CONTROLLER TO THE LOWEST SETTING.
3. TURN POWER SWITCH ON APPLIANCE TO "OFF" POSITION.
4. TURN MAIN MANUAL GAS VALVE TO "OFF" POSITION, (FIGURE "B"). THE VALVE IS "OFF" WHEN THE HANDLE IS PERPENDICULAR TO THE GAS FLOW DIRECTION.
5. THIS APPLIANCE IS EQUIPPED WITH AN IGNITION DEVICE WHICH AUTOMATICALLY LIGHTS THE BURNER, DO NOT TRY TO LIGHT THE BURNER BY HAND.
6. WAIT FIVE (5) MINUTES TO CLEAR OUT ANY GAS. THEN

SMELL FOR GAS, INCLUDING NEAR THE FLOOR. IF YOU SMELL GAS,

1. STOP! FOLLOW "B" IN THE SAFETY INFORMATION ABOVE ON THIS LABEL. IF YOU DON'T SMELL GAS, GO TO THE NEXT STEP.
7. TURN MAIN MANUAL GAS VALVE TO "ON" POSITION, (FIGURE "A"), THE VALVE IS "ON" WHEN THE HANDLE IS PARALLEL TO THE GAS FLOW DIRECTION.
8. TURN POWER SWITCH TO "ON" POSITION.
9. SET THE SYSTEM CONTROLLER TO DESIRED SETTING.
10. IF THE APPLIANCE WILL NOT OPERATE, FOLLOW THE INSTRUCTIONS "TO TURN OFF GAS TO THE APPLIANCE" AND CALL YOUR SERVICE TECHNICIAN OR GAS SUPPLIER.

TO TURN OFF GAS TO APPLIANCE

1. SET THE SYSTEM CONTROLLER TO THE LOWEST SETTING.
2. TURN POWER SWITCH ON APPLIANCE TO "OFF" POSITION.
3. TURN MAIN MANUAL GAS VALVE TO "OFF" POSITION, (FIGURE "B"). THE VALVE IS "OFF" WHEN THE HANDLE IS PERPENDICULAR TO THE GAS FLOW DIRECTION.

⚠ WARNING

THE UNIT SHOULD NOT BE INSTALLED ON A CARPETED FLOOR. A FIRE HAZARD MAY RESULT. Instead, the boiler must be installed on the A. O. Smith Combustible Floor Kit Base or concrete blocks extending beyond the full width and depth of the boiler by at least 3 inches (76.2 mm).

FLAMMABLE ITEMS, PRESSURIZED CONTAINERS OR ANY OTHER POTENTIAL FIRE HAZARDOUS ARTICLES MUST NEVER BE PLACED ON OR ADJACENT TO THE BOILER. OPEN CONTAINERS OF FLAMMABLE MATERIAL SHOULD NOT BE STORED OR USED IN THE SAME ROOM WITH THE BOILER.

Light the unit in accordance with the instructions on the lighting and operating label attached to the boiler. These instructions are repeated on the previous two pages.

**ELECTRONIC HOT SURFACE
IGNITION CONTROL BOARD**

The EMC5000 control system is a fully integrated, state of the art electronic control system. It consists of sensors, output devices, a power switch, a 24vac transformer, wiring, and the following printed circuit boards:

- Central Control Board (CCB). See Figure 1A.
- Flame Control Board (FCB). See Figure 1B.
- User Interface Board (UIB). This part of the User Interface Module (UIM). See Figure 4.
- Power Distribution Board (PDB). See Figure 1C.
- Touch Sensor Board (TSB). This is part of the User Interface Module (UIM). See Figure 4.

The CCB contains circuitry for both master control and flame control for the first stage. The FCB contains circuitry for flame control on up to three additional stages. Dip switches on the CCB and FCB are used to configure the system. The UIB and TSB are included in the User Interface Module (UIM) along with a 4-line by 20-character LCD display. The PDB provides connection points for input power, the water pump, and the transformer. It also distributes power to the system and contains the system fuses.

Multi-stage control is accomplished by means of an internal communication network and the FCB's. One FCB is required for each stage beyond the initial first stage. The CCB also contains an external communications system to allow for connection to a PC, a modem, an EMS system, or something similar. Through this connection multiple boilers can also be linked together.

CAUTION

The internal communications cables should never be connected to the external communications connectors and vice-versa.

There are several microcontrollers used on the board. Three on the CCB, two on the FCB, and one on the UIB. These micros control the temperature and ignition control functions for the boiler.

Inherent in the design are the normal operating sequences and safety features associated with a gas ignition control system. The system continuously performs various diagnostic tests to verify proper appliance and control operation. Should an unsafe condition occur, the control will shut down the burner and display a red fault light as well as indicate the cause of the fault on the display. The operating programs for the system are stored in permanent memory inside the micros. User-selectable operating parameters and a history of detected faults are stored in re-writable memory in the micros. A loss of power does not affect either of the memories.

Inputs To CCB and FCB:

- Temperature Sensors:
 - Temperature probes (CCB - outlet and either inlet or tank is required): The CCB accepts analog temperature inputs from up to three sensors (inlet, outlet and tank).
 - MRHL input (CCB - required): The MRHL (Manual Reset High Limit) is a thermostat switch, which is located inside the output probe. It is a normally closed switch that opens when exposed to a temperature higher than the trip point.
 - Thermostat input (CCB - optional): This input is set up to work with an externally connected thermostat that provides a contact closure. If this input is closed and everything else is in the proper state, a "call for heat" condition will be initiated. These leads should be shorted together, when a thermostat is not being used. If it is desired that the thermostat control the temperature of the boiler, the operating setpoint of the system should be set higher than the temperature that the thermostat is controlling to. This will allow the thermostat to control the boiler. When the thermostat closes, a call for heat will be generated until the thermostat determines that the control temperature has been reached.
- Air Pressure Sensors (open condition indicates fault):
 - Blocked Flue (CCB - required)
 - Normally closed switch that opens if the flue becomes blocked during operation.
 - Powered Vent (CCB - optional): Normally open switch that closes when the powered vent is operating properly. This input is enabled-disabled by a dipswitch on the CCB.
 - Blower Prover High (FCB - required on stages that have blowers): Normally open switch that closes when the air pressures produced by the high-speed blower is above the trip level.
- Gas Pressure Sensors (open condition indicates fault):
 - Low Gas (CCB - required): Normally open switch that closes when the gas pressure rises above the trip level. This input is enabled/disabled by a dipswitch on the CCB.
 - Hi Gas (FCB - optional):

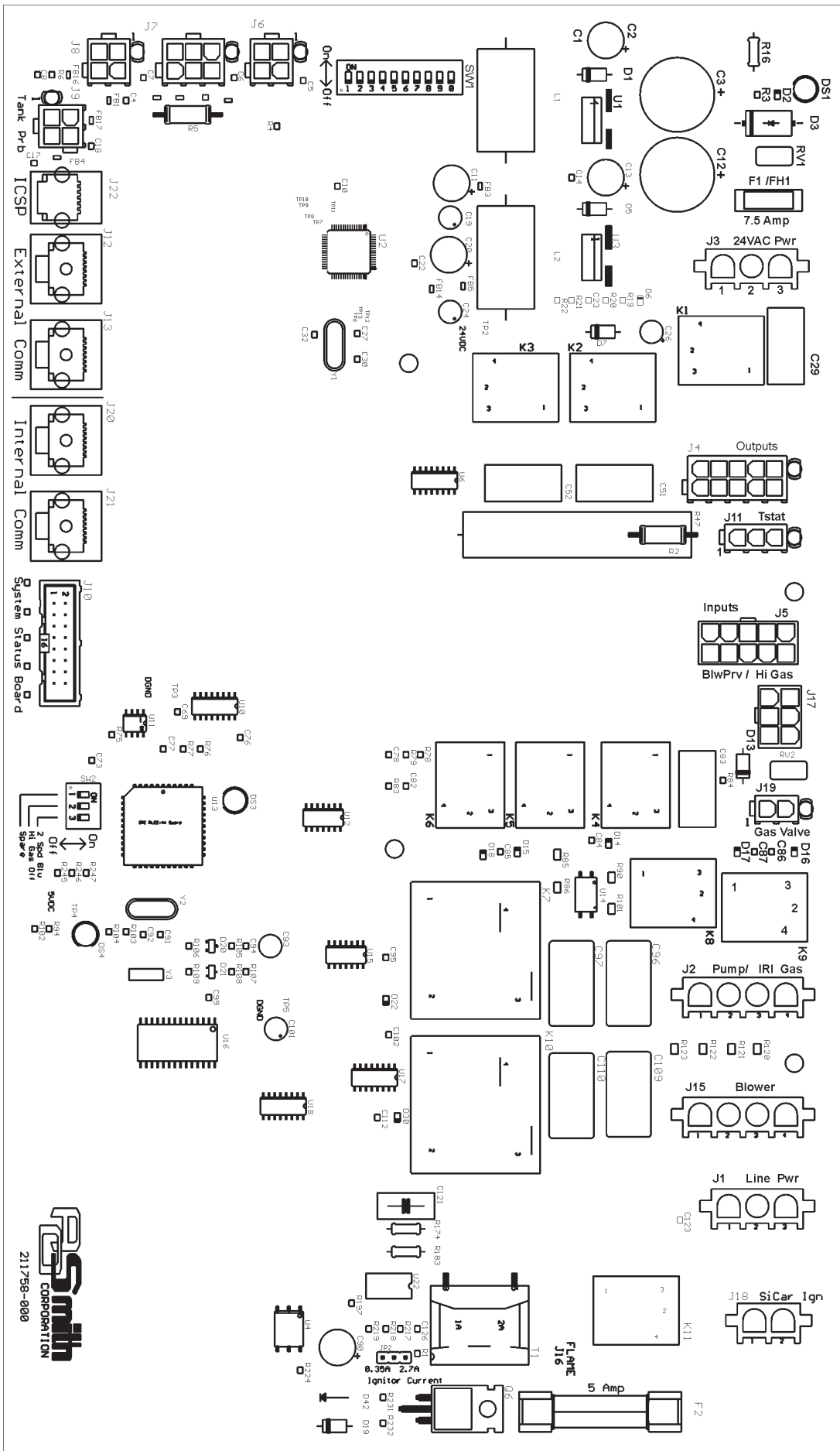

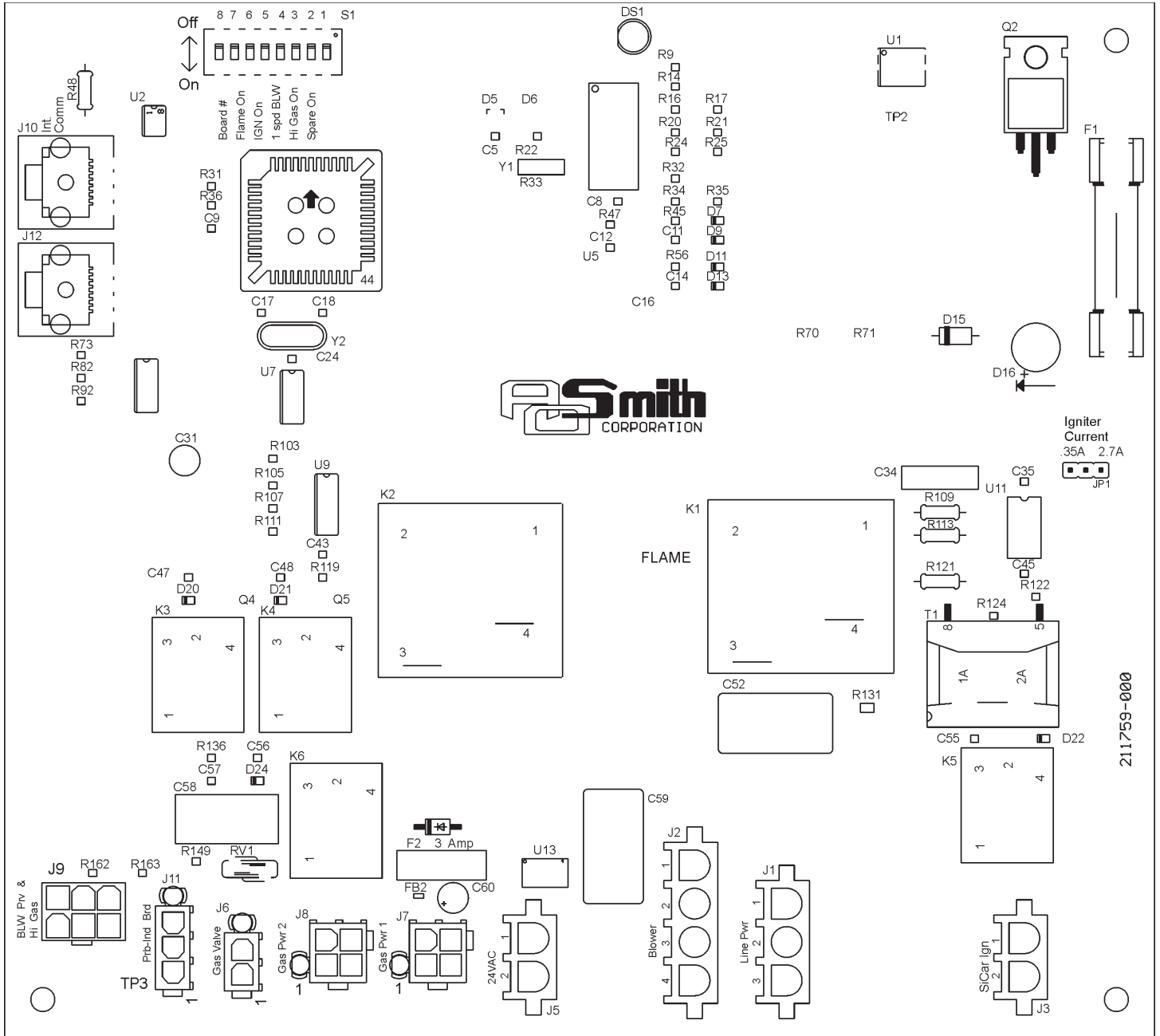

FIGURE 1B. FCB FLAME CONTROL BOARD

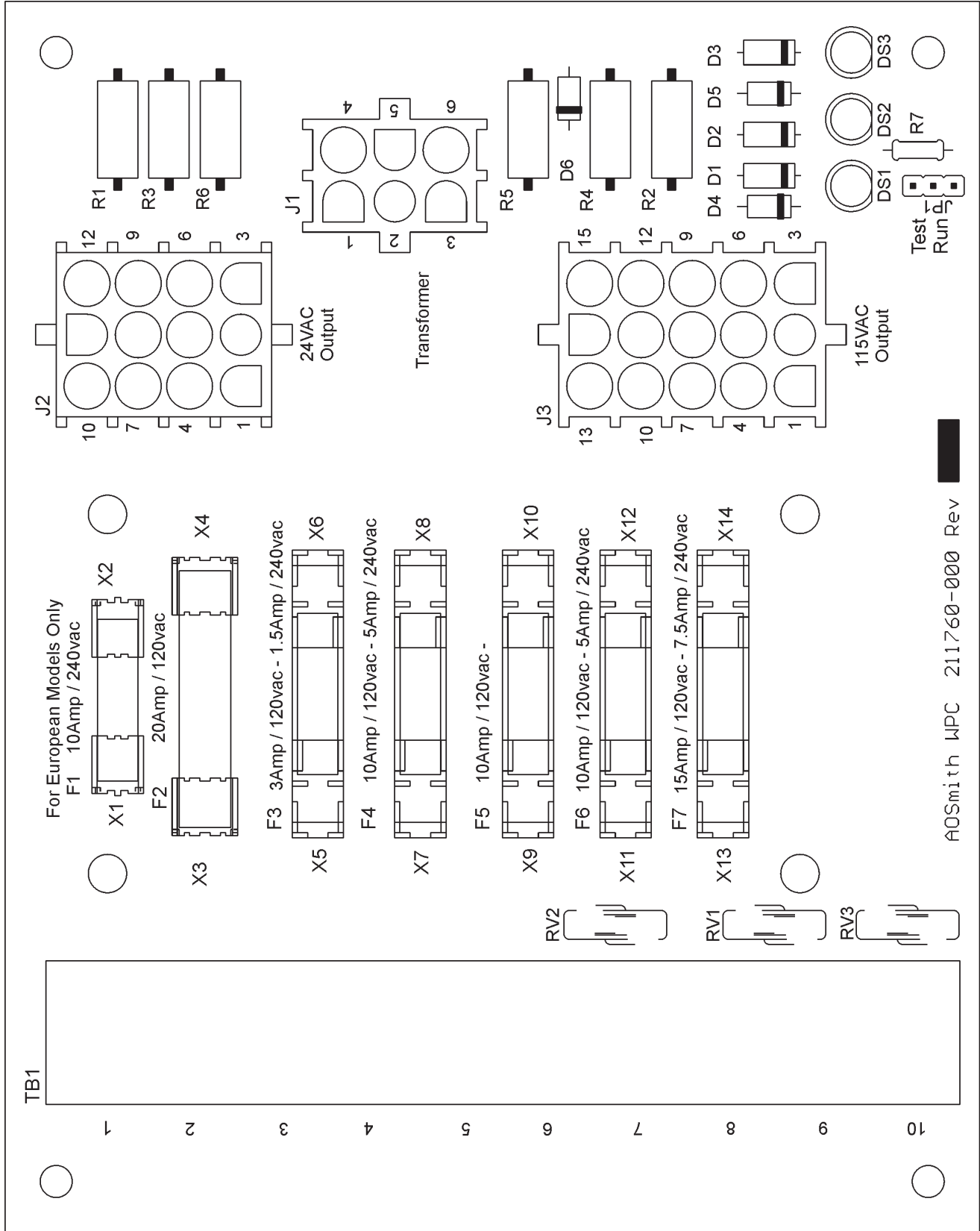

FIGURE 1C. PDB POWER DISTRIBUTION BOARD

Normally closed switch that opens if the gas pressure exceeds a set value. This input is enabled/disabled by a dipswitch on the CCB and FCB's.

- Water Level Sensor (open conditions indicates fault):
 - Low Water Cut Off (CCB - optional):
Normally closed switch opens if a low water condition occurs. This input is enabled/disabled by a dipswitch on the CCB.
- Water Flow Switch:
 - Flow (CCB - required):
Normally open switch that closes when flow reaches a set value.
- IRI Gas Valve Sensor:
 - IRI Gas Valve (CCB - optional):
Normally open switch that closes when the IRI Gas Valve is operating correctly. This input is enabled/disabled by a dipswitch on the CCB.
- Flame Sensor:
 - Flame (FCB - required on stage 1 and on stage 2 of a 4 stage system - optional on others):
Returns a signal to the microprocessor if flame is detected on the burner. If the probe is missing or shorted, the flame will not be detected. This input is enabled/disabled by a dipswitch on the FCB.

Outputs from CCB and FCB's:

- Relay Contact Outputs:
 - IRI Gas Valve (CCB - 120vac- optional):
Provides electrical power to operate an IRI Gas Valve device.
 - Alarm (CCB - 24vac- optional):
Provides electrical power to operate on external alarm. This can be an audio device (i.e. Sonalert), a visual device (lamp), or any other device that will operate with the voltage and current level provided.
 - Pump (CCB - 120vac - required on systems that do not have an external pump):
Provides electrical power to directly operate a pump or the coil of an externally connected contactor.
 - Powered Vent (CCB - 24vac - optional):
Provides electrical power to operate a powered vent.
 - Low and High Speed Blowers (FCB - 120vac - required on stage 1 and on stage 2 of a 4-stage system and optional on others.):
Independent outputs that provide power to operate low and high blower output only. Dip switches on the FCB's enable/disable the use of blowers on stages 2, 3 and 4.
 - Igniter (FCB - 120vac - required on stage 1 and on stage 2 of a 4-stage system and optional on others.):
Provides power to operate the igniters. Dip switches on the FCB's enables/disables the use of an igniter on stages 2, 3 and 4.
 - Gas Valve (FCB - 24vac - required):
Provides power to activate the gas valve. The gas valve cannot be activated when the High Limit Switch contacts are open.
- Direct Connection Output:
 - Low Water Cut Off (CCB - 24vac - optional):
Directly connected to the 24 vac line to provide power to operate an external LWCO device.

Line Polarity Indicator & Fuse Protection

CCB/FCB Indicator Lamps & Fuses

A green LED is mounted on the PDB to indicate when line voltage is applied. (The PDB also contains a yellow LED, a red LED, and a test-run jumper, that are used during installation to verify proper

power connections.) A red LED on the CCB is used to indicate when the 24 vac input fuse has blown. The FCB's also have fuses on their 24vac power line. (Recommended replacement fuses are: Littlefuse p/n 29707.5 for the 7.5 amp CCB fuse, and Littlefuse p/n 297003 for the 3 amp FCB fuses.) **Repeated failure of fuse is an indication of failure to some part of the system.**

Yellow LED's are located near the micros on the CCB and FCB's. These LED's are "heartbeat indicators" and blink approximately twice per second to indicate that the micros are running. (The blink rate of the LED next to the micro that controls the silicon nitrite igniter will change when the igniter is being powered and when a fault is detected with the operation of that igniter.)

CCB/FCB JUMPERS:

The CCB has two jumpers and the FCB has one. JP1 on the CCB is used to terminate the external communications line. It is normally left "OFF" and installed when the external cable is very long.

Igniters

EMC-5000 system includes a Silicon Carbide igniter, Norton type 271Y (at 2.7 amps). The igniter is activated through relays on the system boards and use a current sensing system for proof of ignition. This circuit monitors the igniter operation and signal the CCB and FCB micros when faults are detected. A yellow "heartbeat" LED located next to the dedicated micro flashes a two digit code when faults are detected.

Appliance Operating Sequence

NOTE: The following sequence is based on a four-stage system with all options and two-speed blowers. It is characteristic of most system configurations.

1. The EMC5000 controller has four modes of operation: Initialization, Standby, Running and Service. The internal CCB and FCB micros control these modes through a sequence of steps (or States) which are further described in the "UIM Operating Procedures" section.

2. When power is applied to the system, it enters the Initialization mode and the following automatic functions are performed:

- A. O. Smith opening screen is displayed.
- The system goes through a self-calibration indicated by the green running LED blinking and then staying on: next the red service LED and yellow standby LEDs come on; next the stage 1 service and running LEDs blink on and off followed by stage 2, stage 3, stage 4 and then back to stage 1,2,3,4 LEDs.
- Stored values are recalled from memory.
- Configuration dipswitches are read.
- Pending faults are recalled
- Micros on all boards start running (indicated by a flashing Yellow LED near each micro)
- Input sensors are read
- Communications between micros and boards is established
- FCB's are configured with the number of ignition trials to run.

CCB/FCB Dip Switches:

Dipswitch configurations are READ ONLY ON POWER UP. These switches are only to be set at the factory or by authorized trained personnel only! Once set at installation they generally remain that way for the duration of the life of the product. If a switch is changed, power must be cycled before the change will take effect. The status of all dipswitches can be observed on the system status screen on the UIM. **CCB - Ten Position Dipswitch (Central Control Section):**

	<u>Boilers</u>	<u>Water Heaters</u>
Switch 1: Selection of the type of boiler application:	On = GB	Off = GW
Switch 2: Trials for ignition:	On = 3	Off = 1
Switch 3: IRI Gas Valve Option:	On = IRI	Off = No IRI
Switch 4: Controlling Probe:	On = Tank (Remote)	Off = Inlet
Switch 5: Powered Vent:	On = Yes	Off = No
Switch 6: Low Water Cut Off:	On = Yes	Off = No
Switch 7: Low Gas	On = Yes	Off = No
Switch 8: Spare:		
Switch 9 & 10. Number stages (FCB's):	9 10	#stages
	Off Off	= 1
	Off On	= 2
	On Off	= 3
	On On	= 4

NOTE: If the unit powers up with the number of stages selected by dip switches exceeding the number of FCBs, the CCB will detect this condition and go into a hard lockout. After changing the dip switches to the correct number of stages, the power must be cycled on and off to accept the change.

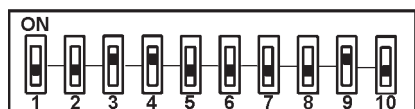

Example of Dip Switch configuration:

GW model, 1 ignition trial, IRI, Tank Probe used, No Power Vent, No LWCO, No Low Gas, 3 stage.

CCB - Three position Dipswitch (Flame Control Section):

This dipswitch is similar to the FCB dipswitches described below, but with only three switches being used: the number of blower speeds (switch #3), Hi Gas option (switch #2) and a spare (switch #1). Only the blower speed selection and Hi Gas are required because FCB1 always has a blower, igniter, flame checking, and the address is always stage 1.

FCB - Eight position Dipswitch:

Switch 1: Spare:		
Switch 2: Hi Gas:	On = Yes	Off = No
Switch 3: Number of Blower Speeds:	On = 1 speed,	Off = 2 speed
Switch 4: Igniter used:	On = Yes,	Off = No
Switch 5*: Blower used:	On = Yes,	Off = No
Switch 6: Flame Checked:	On = Yes,	Off = No
Switch 7 & 8. Stage selection:	7 8	Stage #
	Off Off	Not allowed
	On Off	2
	Off On	3
	On On	4

*When switch 5 is in off (no blower) position, switch 3 (blower speeds) is ignored.

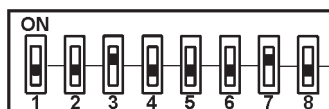

Example of Dip Switch configuration:

No High Gas, 1 blower speed, no igniter, no blower, flame not checked, Stage 2.

3. After initialization is complete (approximately 10 seconds) the system turns the green LED off and goes to the standby mode (yellow "Standby" LED on), unless a previously stored fault has been recalled, which will send the system into the service model (red "Service" LED on). In standby mode the display shows the temperature screen and in fault mode the current error screen is displayed.
4. The system then compares the temperature read from the controlling probe (inlet or tank) to the setpoint temperature. If the temperature is less than the operating setpoint minus the differential temperature and the thermostat input is closed then a call for heat is established and the system shifts to the run mode (green "Running" LED turns on).
5. The heating sequence begins by applying power to the pump and, if selected, the powered vent and the IRI gas valve.
6. After a few seconds the High Speed Blower (on all stages with the blower dipswitch turned on) are turned on to perform a cold purge of the chamber.
7. After cold purging is complete the blowers are turned off and the stage 1 blower is turned on.
8. The stage 1 igniter is turned on.
9. After 18 seconds the system checks that the igniter has turned on. If this is ok then the system turns on the gas valve.
10. After 1.5 seconds the system checks the status of the flame sensor. If flame is detected the system proceeds to the next stage. Note: If the "Ignition Tries" dipswitch is set for 3 tries the system will not declare an error until it tries the ignition sequence three times. If it is set to 1 try then the system will declare an error anytime a fault is detected.
11. The system now activates the other FCB stages depending upon a control algorithm scheme that is described below. For this example it is assumed that all four stages of heat are required.
12. The stage 2 high-speed blower is turned on to purge the chamber.
13. After approximately 10 seconds the stage 2 igniter is turned on.
14. After 18 seconds the system checks that the igniter has turned on. If this is ok then the system turns on the gas valve.
15. After 1.5 seconds the system checks the status of the flame sensor. If flame is detected the system continues to the next stage.
16. Steps 12 through 15 are then repeated for stage 3 and 4.
17. The system is now in the heating mode with all four stages on and will remain in this mode until the call for heat is satisfied or a fault occurs.

NOTE: In standby and running modes the system constantly monitors the signals and the internal operation for faults. Any detected fault will halt the heating sequence and shift the system to the service mode, where the detected fault will be displayed.

Temperature Setpoints (System Control Algorithm)

The boiler has a hysteresis type control, which means that it will begin heating the water when the temperature sensed by the control probe (inlet or tank) falls below the operating setpoint minus the differential setpoint for stage 1. It will stop heating the water when the temperature rises to the operating setpoint. If the system has multiple stages then the differential setpoint for each stage is also subtracted from the operating setpoint. The following examples will further explain this operation.

Setup: 2 stage system, operating setpoint - 140, stage 1 to 2 differential setpoints = 10.

Example 1. Temperature begins at 150 and drops to 90, see Figure 2A. At 140 the system remains in idle mode. As the temp drops to 130 (140-10) stage 1 turns on and stage 2 remains off. At 120 stage 2 also turns on.

Example 2. Temperature begins at 90 and rises to 150, see Figure 2B. At 100 both stages are on. This is the case when a boiler is first started and the controlling temperature is below the operating setpoint minus all of the differential setpoints. At that time both stages are turned on, in sequence from 1 to 2. At 130 stage 2 turns off. At 140 both stages are off.

Stages 1 and 2 will turn on in sequence from 1 to 2.

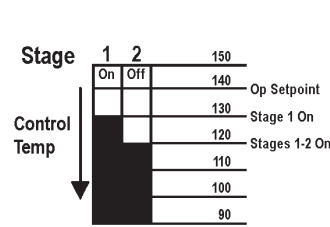

FIGURE 2A.

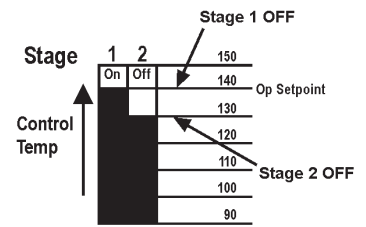

FIGURE 2B.

The following status information is displayed from this screen:

Status Displayed	*(True Condition)	Input	Output
MRHL	Outlet temperature too high	open	----
LWCO	Water Level low	open	----
Blk Flue	Flue blocked	open	----
Flow	Water flowing	closed	----
Low Gas	Gas pressure low	open	----
Tstat	Thermostat requesting heat	closed	----
Hi Limit	Outlet temp exceeds High Limit setpoint	----	----
Pump	Pump output activated	----	On
IRI Gas Pwr	IRI output relay activated	----	On
IRI Gas	IRI Gas Valve on	closed	----
Pwr Vent	Power Vent running	closed	----
Alarm	Alarm output activated	----	On
Pwr Vent Pwr	Power Vent output relay activated	----	On
	----- STAGES 1 to 4 -----		
BlwHi Prv	Blower pressure sufficient	closed	----
Blw Hi	Blower High output activated	----	On
BlwLo Prv	Blower pressure sufficient	closed	----
Blw Lo	Blower low output activated	----	On
Ignt Cur	Igniter current sufficient for ignition	----	----
Ignt	Igniter output is activated	----	On
Gas Relay	Gas output relay activated	----	On
Hi Gas	Gas pressure too high	open	----
Flame	Flame detected	----	----

FIGURE 3. SYSTEM STATUS SCREEN.

UIM Operating Procedures

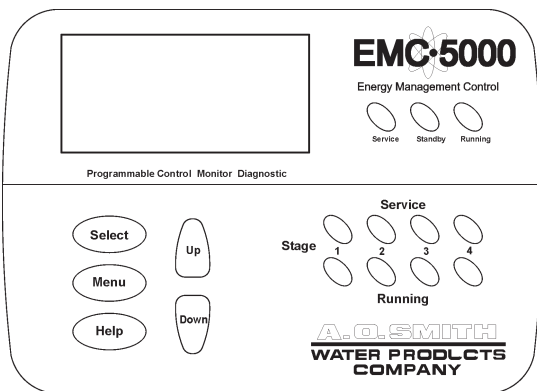

FIGURE 4. UIM.

The UIM receives commands from the user and displays operational information to the user via an LCD (liquid crystal display) up to eleven LED's, and five touch switches. The LCD provides information to the user by the use of 10 menu-activated screens. Within each of the screens, helpful information can be displayed by pressing the "Help" button. The LED's visually inform the user about the mode the system is in. The touch switches allow the user to control the operation of the system. The operation of these parts is described below:

UIM Screens:

On all screens a double vertical bar appears on the right side of the display each time a key is touched to indicate that a key has been activated. On several screens an indicator ">" appears on the left side of the display to indicate the active line. The "Up/Down" keys are used to move the indicator to the desired line and the "Select" key is pressed to select the line. Also, on most

of the screens, up/down arrows appear on the right side of the screen to indicate that there are additional lines either above or below the displayed four lines.

- **Menu Screen:**
Displayed when the user presses the "Menu" key. This screen is the selection point for the other 9 screens.
- **Temperature Screen:**
Displays the sensed temperatures of the Outlet, Inlet, and Tank probes. Also displayed is the calculated Delta T (Outlet minus Inlet) for the system. Shorted ("Short") and disconnected ("----") probes are also displayed.
- **System Status Screen:**
This screen is used to view the status of switch inputs and output states. An asterisk (*) is displayed next to the label when the status is "True" (the description is fulfilled). For example, if water is flowing, or detected by the flow sensor, then an "*" will appear in front of the Flow label (i.e. *Flow). Another example would be the High Limit Switch. If the outlet temperature is too high the display will show: *Hi Limit.

NOTE: The LWCO, IRI Gas Valve, Powered Vent and High Gas inputs are optional inputs. Flame sensing, Igniters, and Blowers are optional on Stages 2, 3 and 4. (Except on a 4-stage system, stage 2 always has an Igniter, Blower, and Flame Sensor. Those dipswitches on stage 2 are not relevant.) One or two speed blowers can be used on any stage.

The System monitors the inputs at these times:

- High Limit, LWCO, Blocked Flue, Low Gas, Hi Limit, and Hi Gas - at all times for a fault condition.
- Tstat - at all times for open/closed conditions.
- Pump, IRI Gas and Powered Vent - for an on condition when their respective outputs (Pump, IRI Gas Pwr, Powered Vent Power) are turned on and an off condition at all other times.

- Flow - for an on condition when the pump is on (no check for off state)
- High Speed Blower Prover - when the High Speed Blower is on.
- Low Speed Blower Prover - when either the High or Low Speed Blowers are on.
- Igniter Current - for an on condition approximately 18 seconds after the Igniter is turned on until the igniter is turned off and an off condition at all other times.
- Flame - for an on condition approximately 5 seconds after the gas valve is turned on until the valve is turned off and at all other times for an off condition.
- Hard Fault State: (See "Fault Description" section for list of soft and Auto Reset faults.) The CCB turns off the Powered Vent and the IRI Gas. The pump remains on for the selected post-circulate time to cycle the hot water out of the boiler. The FCB's are commanded to shut down and the Alarm output is turned on. The green LED turns off and the red "Service" turns on and off (flashes). The only way to exit this state is for the user to press the Select key while the current error screen is displayed. The fault is logged in the error history when the fault state is exited.

Control Status Screen:

Displays the software that the CCB and FCB micros are in. The CCB has 8 possible states and the FCB's have 9. The normal CCB states sequence is to move from Idle, to Pre-Circulate, then to Heating Stage 1-4 when a call for heat is initiated. Once heat has been satisfied, the sequence moves to Post-Circulate and then back to Idle. If a fault occurs at any time, the process jumps out of sequence and goes directly to the appropriate Hard or Soft Fault state.

Description of CCB control states:

- Idle:
The yellow "Standby" LED is turned on and the system waits for a heat request (determined by the Thermostat and controlling probe inputs). All outputs are off in this state except that if the Post-Circulate time is set to continuous the pump will be on. When the heat request is received, the system moves to the Pre-Circulate state.
- Pre-Circulate:
The yellow LED is turned off and the green "Running" LED is turned on. The green LED will remain on for all other states except the fault states. If enabled the powered vent and the IRI gas valve are turned on. A command is sent to all active stages to cold purge the system. Cold purging clears out any combustion gas that may be in the combustion chamber. When purging is complete the system moves to the Heat State.
- Heat Stages 1-4:
The system will command the FCB micros to start their heat sequence starting with stage 1. Stages 2 through 4 will be activated in order based on an algorithm that determines how much heat is needed. The system will remain in this state until the heat request is satisfied, the Tstat is opened, or a fault occurs.
- Soft Fault State: (See "Fault Description" section for list of soft and Auto Reset faults.)
The CCB turns off the Powered Vent and the IRI Gas. The pump remains on for the selected post-circulate time to cycle the hot water out of the boiler. The FCB's are commanded to shut down and the Alarm output is turned on. The green LED turns off and the red "Service" turns on. The CCB remains in this state until one of the following occurs:
 - One hour passes (automatic restart after one hour)
 - If Communications error system will automatically restart if communications are OK.
 - If user presses Select key while current error screen is displayed (Hard reset).
 - If high-limit error - the outlet temperature drops below the high limit trip point minus the high limit differential. (outlet water temperature drops to safe level).
The fault is logged in the error history when the fault state is exited.

While the CCB is in the Heating mode the activated FCB stage moves from Idle, to Pre-Purge, to Heat Igniter, to Check for Flame, and then to Heating. The process waits in this state until the call for heat is satisfied, the thermostat input is opened, or a fault occurs. When heat is satisfied, the sequence continues to Post-Purge and then back to Idle. If three tries for ignition has been selected on the CCB dipswitch and flame is not detected at the appropriate time, then the sequence moves to the Inter-Purge state for 15 seconds and the FCB heat sequence is repeated. If flame is still not detected after the third try the process declares a fault, jumps out of sequence and goes to the error state. Other types of faults detected at any time will also cause a jump to the error state.

Description of FCB control states:

- Idle State:
If a Silicon Nitrite igniter is being used then its condition is determined and any error is declared. The system will remain in this state until the CCB requests a heating cycle or a cold purge. The blowers, igniter, and gas relay are turned off.
- Pre-Purge State:
If the stage does not have a blower, this state is skipped and the system advances to the Heat Igniter State. Otherwise the Hi-Speed Blower is turned on. After 10 to 34 seconds (34 seconds for cold purging) the system switches to the Heat Igniter State. If the blower on this stage is a 2-speed then the Hi-Speed is turned off and the Low-Speed is turned on before switching states.
- Heat Igniter State:
The igniter relay is turned on and a go command is sent. Responses returned from the current feedback sensor is checked. If the current feedback sensor is still active after approximately 18 seconds have passed, then the system advances to the Check for Flame state. If the signals do not occur then an error is declared unless the Ignition Tries dipswitch is set to three. Then the system advances to Inter-Purge state and retries ignition until it completes three tries. Then it will declare an error.
- Check for Flame State:
The gas valve is turned on. After 1.5 seconds, the system checks that the gas valve relay is on. If it is not, the ignition trial is considered to have failed and the system advances to the Inter-Purge state, if any ignition trials remain, otherwise an error is declared.
The flame sensor is checked. If flame is detected, the igniter is turned off and if the blower is low speed, it is switched to high speed. The state machine then advances to the Heating State. If after 5 seconds, the flame is still not sensed then the ignition trial is considered to have failed. The state machine advances to Inter-Purge if any ignition trials remain, otherwise an error is declared.

- **Heating State:**
The system remains in this state until the call for heat is cancelled or a fault occurs. The system returns to the Idle state if the call for heat is cancelled and to the appropriate fault state if a fault occurred.
- **Inter-Purge State:**
The gas valve and the igniter are turned off. The low blower is turned off and the high-speed blower on. After approximately 15 seconds the high-speed blower is turned off, the low speed blower on, and the system goes back to the Heating Igniter State.
- **Post-Purge State**
The gas valve and the igniter are turned off. If this stage does not have a blower the system returns to the idle state. If it does have a blower then the low-speed blower is turned off and the high-speed blower on. After approximately 25 seconds, the system returns to the Idle state.
- **Error State**
The gas valve and the igniter are turned off. The FCB micro tells the CCB micro which error has occurred. The system waits in this state until the CCB sends a command to clear the error. Then the Silicon Nitrite micro is reset and the system returns to the idle state.
- **Cold Purge State**
Cold purge occurs when the CCB micro commands all blowers to go on before lighting the first stage to clean the unit of gases. This state normally lasts approximately 32 seconds but on a special situation can last up to 5 minutes. If on the first call for heat after power up, any blower prover switch is open, this state will take up to 5 minutes before declaring an error. This special mode is used by service technicians to adjust the blower shutters.

The CCB will wait the normal cold purge time (normally 32 seconds) before checking for activation of all active blower provers. If all are active at this time the CCB cancels the cold purge request. After the first cold purge has been done a flag is set to prevent further activation of the shutter adjust 5 min. delay. Any further requests for cold purge will last the normal cold purge time. The FCB will go into fault mode if the blower prover does not activate after 15 seconds. This time allows the blower relay to activate, the blower to come up to speed, and the response from the blower prover to be filtered.

User Settings Screen:

Each setpoint or user setting has either a limited selection of values, or a limited range of values. The Up/Down keys are used to change values. After changing an item, the Select key is pressed to accept the change, or the Menu key is pressed to reject the change and restore the item to its original value. The following setpoints can be changed:

Operating Setpoint:

This setpoint sets the base temperature for the control algorithm, see page 10.

OPERATING SETPOINT ADJUSTMENT PROCEDURE

The system has a standard programmable Operating Setpoint range of 70 Degrees F to 190 Degrees F for a GW and of 70 Degrees F to 220 Degrees F for a GB. The user can easily change the Operating Setpoint at any time by using the following procedure. When any configuration or setpoint is changed (and the Select key touched), the new value is IMMEDIATELY saved to non-volatile memory. The factory default setting is 120 Degrees F.

1. Touch the MENU key.
2. Scroll the ">" with the DOWN key next to the USER SETTING SCREEN.

3. Touch the SELECT key.
4. Scroll the ">" with the DOWN key until it is pointing to OPERATING SETPOINT.
5. Touch the SELECT key.
6. Use the UP or DOWN key to select the value you wish to enter.
7. Touch the SELECT key to accept and store the new value.

- **High Limit:**
The outlet temperature probe contains both the Manual Reset High Limit Switch and a thermistor for temperature measurement. The sensed outlet temperature is used for the automatically resettable High Limit setpoint. If the sensed outlet temperature exceeds the High Limit setpoint, a "soft lockout" condition will occur and the burner will be shut off. This fault condition is automatically cleared when the temperature drops below the high limit setpoint minus the high limit differential.

HIGH LIMIT SETPOINT ADJUSTMENT PROCEDURE

The High Limit setpoint has a range of 90 Degrees F to 210 Degrees F for a GW and a range of 90 Degrees to 235 Degrees F for a GB. Use the following procedure to change the automatically resettable High Limit Setpoint:

1. Touch the MENU key.
2. Scroll the ">" with the DOWN key next to USER SETTING SCREEN.
3. Touch the SELECT key.
4. Scroll the ">" with the DOWN key until it is pointing to HIGH LIMIT SETPOINT.
5. Touch the SELECT KEY.
6. Use the UP and DOWN key to select the value you wish to enter.
7. Touch the SELECT key to accept and store the new value.

- **High Limit Differential:**
The outlet temperature must be below the automatic High Limit setpoint minus the High Limit Differential setpoint before a call for heat can be generated.

HIGH LIMIT DIFFERENTIAL SETPOINT ADJUSTMENT PROCEDURE

The High Limit Differential Setpoint has a range of 1 Degree F to 50 Degrees F for all models. Use the following procedure to change the High Limit Differential Setpoint:

1. Touch the MENU key.
2. Scroll the ">" with the down key next to USER SETTING SCREEN.
3. Touch the SELECT key.
4. Scroll the ">" with the DOWN key until it is pointing to HIGH LIMIT DIFFERENTIAL SETPOINT.
5. Touch the SELECT key.

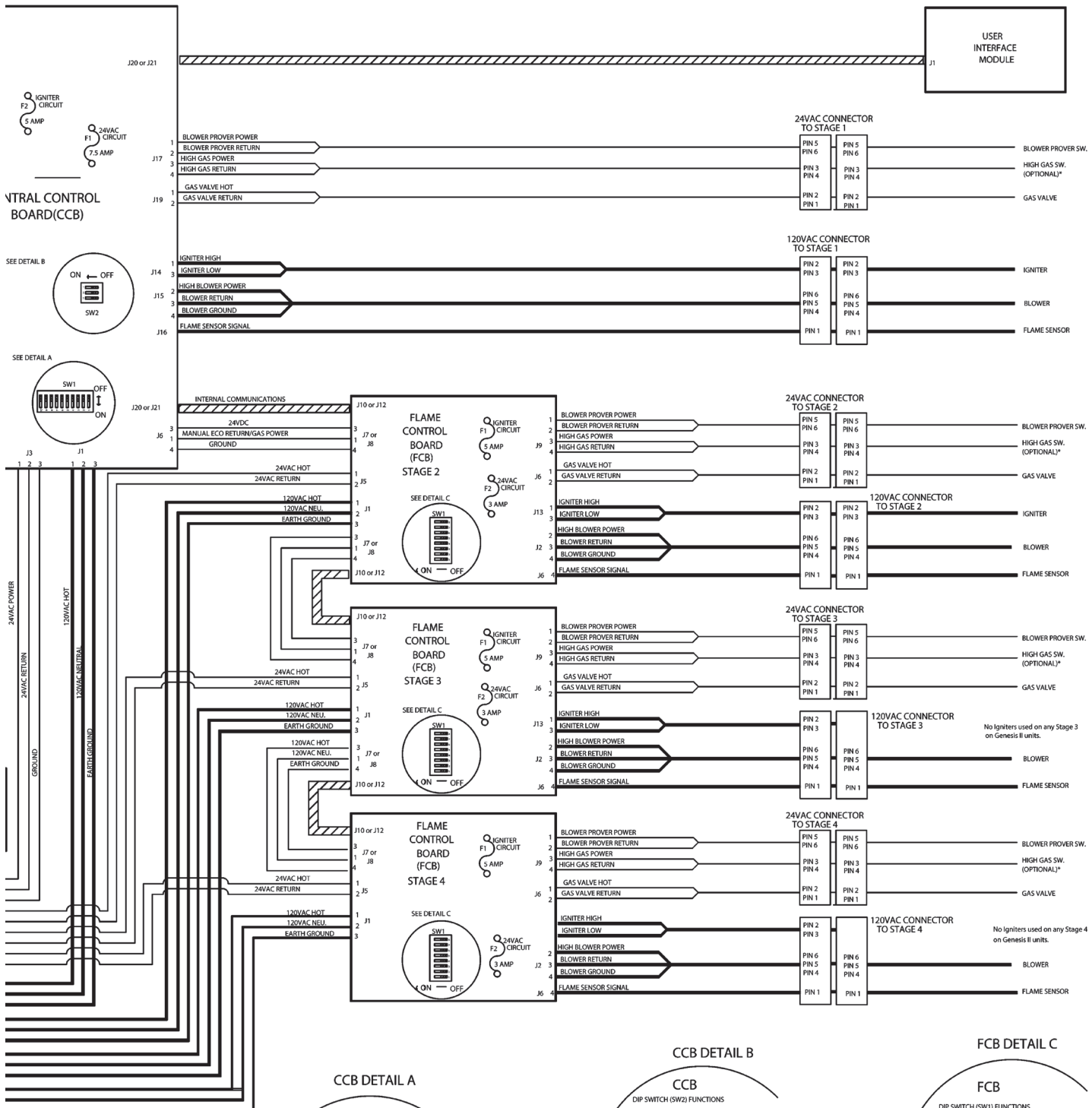

NEUTRAL CONTROL BOARD (CCB)

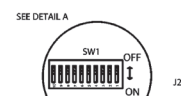

FLAME CONTROL BOARD (FCB) STAGE 2

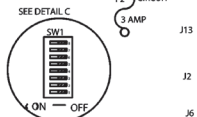

FLAME CONTROL BOARD (FCB) STAGE 3

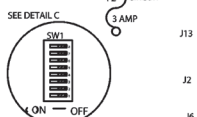

FLAME CONTROL BOARD (FCB) STAGE 4

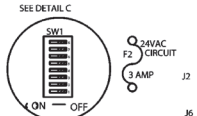

CCB

DIP SWITCH (SW1) FUNCTIONS

POSITION	ON	OFF	FUNCTION
1	GW	GB	TYPE OF BOILER
2	1	3	IGNITION TRIALS
3	IRI	NO IRI	IRI GAS VALVE
4	INLET TANK	CONTROLLING PROBE	
5	ON	OFF	POWERED VENT
6	ON	OFF	LOW-WATER CUTOFF
7	ON	OFF	LOW GAS SWITCH
8			SPARE
9			SEE TABLE NUMBER OF STAGES
10			SEE TABLE 1 TO 4

CCB

DIP SWITCH (SW2) FUNCTIONS

POSITION	ON	OFF	FUNCTION
1			SPARE
2	YES	NO	HIGH GAS SWITCH
3	1	2	BLOWER SPEEDS

FCB

DIP SWITCH (SW1) FUNCTIONS

POSITION	ON	OFF	FUNCTION
1			SPARE
2	YES	NO	HIGH GAS SW
3	1	2	BLOWER SPEEDS
4	YES	NO	IGNITER
5	YES	NO	BLOWER
6	YES	NO	FLAME SENSE
7			SEE TABLE BOARD
8			SEE TABLE ADDRESS

OF STAGES TABLE

SW 9	SW 10	# OF STAGES
0	0	1
0	1	2
1	0	3
1	1	4

STAGE ADDRESS TABLE

SW 7	SW 8	STAGE #
0	0	NOT ALLOWED
1	0	2
0	1	3
1	1	4

A.O.SMITH GENESIS II (1000-2500)

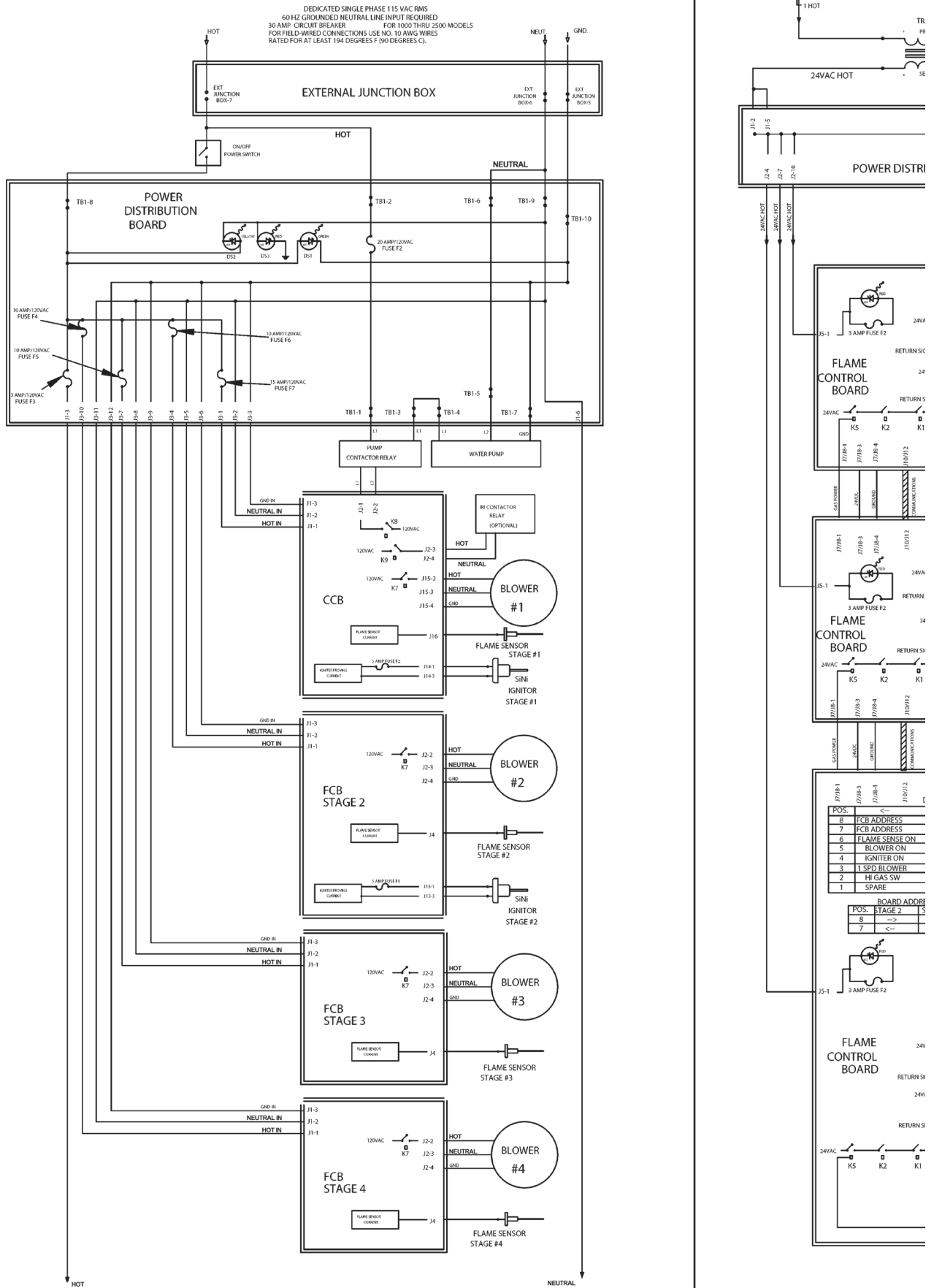
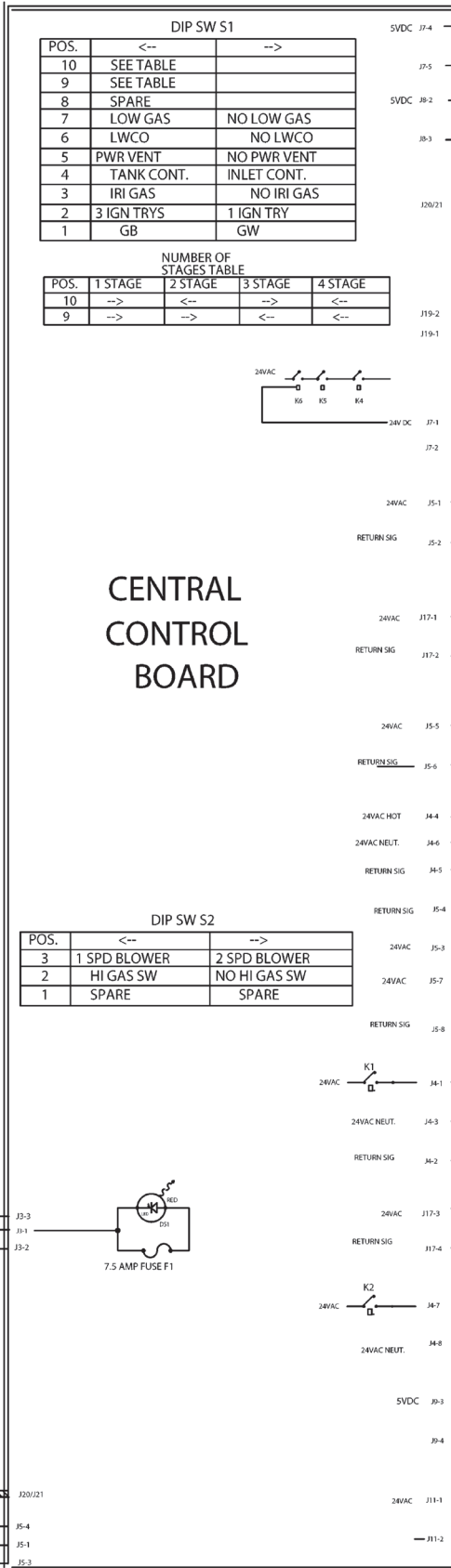
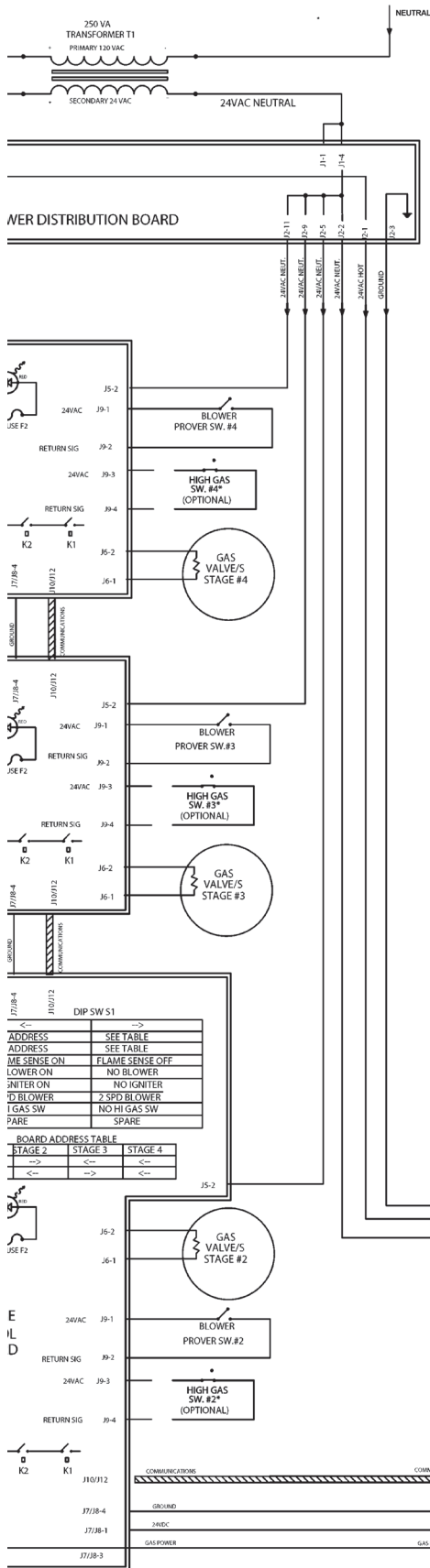

FIGURE 6. SCHEMATIC D

SCHEMATIC DIAGRAM



*OPTIONAL INPUTS
THIS UNIT MAY HAVE ALL, SOME, OR NONE
OF THE ABOVE OPTIONS.

6. Use the UP or DOWN key to select the value you wish to enter.
7. Touch the SELECT key to accept and store the new value.

OPERATING DIFFERENTIAL SETPOINT ADJUSTMENT PROCEDURE

Each of the stages has an independent Operating Differential Setpoint. The range of these setpoints is from 1 Degree F to 50 Degrees F for all models. Use the following procedure to change this setpoint:

1. Touch the MENU key.
2. Scroll the ">" with the DOWN key next to USER SETTING SCREEN.
3. Touch the SELECT key.
4. Scroll the ">" with the DOWN key until it is pointing to OPERATING DIFFERENTIAL SETPOINT.
5. Touch the SELECT key.
6. Scroll the ">" with the DOWN key until it is pointing to the STAGE you want.
7. Touch the SELECT KEY.
8. Use the UP and DOWN key to select the value you wish to enter.
9. Touch the SELECT key to accept and store the new value.

- **Temperature Units:**
Temperature can be displayed in either °F or °C units.
- **Post Circulate Delay Time:**
The time circulation pump will stay on after the burner is turned off. The time in seconds is adjustable with the following values: 45, 90, 180 or continuous. If the continuous value is selected the pump will remain on at all times and the post circulate state time will be set at 45 seconds.
- **Network Address:**
This is a unique number assigned to this boiler to differentiate it from other boilers or water heater on the same A. O. Smith proprietary network. A valid Network Address can be any number from 1 to 31. It is set by default to zero, which is an invalid address. The boiler will not communicate until it is changed to a valid and unique number. This prevents two units from trying to respond to the same request from the PC or supervisory network device.

Configuration Settings Screen:

Displays the status of the dipswitches installed on all boards as described on page 9.

Log & System Info Screen:

Displays the following information:

Elapsed hours of operation (Total time system has been powered up)

Number of running minutes (Number of minutes system has been in the run mode)

Number of cycles for each stage (Number of times stage has been in heat mode).

Kbtu rating of the boiler (0 to 5750Kbtu in 10Kbtu increments)

The software revision level of the CCB, and FCB micro-controllers.

Current Error Screen:

- Displays the last error that the system has detected plus a timestamp of when the error occurred. (The time stamp is based

on the elapsed hours value at the time the error occurred. It is displayed in hours and minutes. This error remains displayed as long as it is still valid. When cleared it is moved to the Error History Screen. The system will automatically jump to this screen when an error is detected. It will also go to this screen upon power-up if an error was still valid when power was turned off.

NOTE: Errors are cleared from this screen by pressing the "select" key.

- **Error History Screen:**

This screen displays a list of the last 9 errors (with timestamps) that have occurred. The last error to occur is displayed first. If a new error occurs this screen is presented to display the error.

- **Reload Defaults Screen:**

From this screen the user can restore the factory default values for screen adjustable configurations by pressing the Select key. The values restored are as follows:

GW Models

Oper Setpnt (Operating Setpoint) = 145° F (63° C)

Stage1 Diff (Operating Setpoint Differential) = 3° F (2° C)

Stage2 Diff (Operating Setpoint Differential) = 6° F (3° C)

Hi Llimit (High Limit Setpoint) = 210° F (99° C)

Hi Limit Dif (High Limit Differential) = 20° F (11° C)

GB Models

Oper Setpnt (Operating Setpoint) = 190° F (88° C)

Stage1 Diff (Operating Setpoint Differential) = 3° F (2° C)

Stage2 Diff (Operating Setpoint Differential) = 6° F (3° C)

Hi Llimit (High Limit Setpoint) = 230° F (110° C)

Hi Limit Dif (High Limit Differential) = 20° F (11° C)

Both Models

Tempert Units (Temperature Units) = F

Post Cir Secs (Post Circulation pump delay) = 45 seconds

Network Address (Network Address) = (non-valid address)

UIM Touch Switches

Below the LCD display are five touch switches or keys, that the operator uses to operate the system.

- **Menu Key:**
Pressing this key activates the menu screen where the other screens can be accessed.
- **Select Key:**
This key performs several functions. Screens can be selected from the menu screen by pressing this key when the ">" appears next to the screen desired.

On the User Settings screen items that appear next to a ">" symbol can be selected with this key. If a setpoint configuration item is selected, the ">" will then flash slowly to indicate that the item has been selected. The Up and Down keys are then used to change its value.

From the Current Error Screen this key is used to reset the system from an error:

- **Up and Down Keys:**
These keys are used to move upwards and downwards in screens to reach a desired item and to change setpoints and user settings. They have an auto increment/decrement feature for some of the configurations and values. When you first press one of the keys and value changes by 1 count, then wait 1/2 second and changes slowly until the key is released or if held for 3 or more seconds it will change the value quickly.

- **Help Key:**
Pressing the Help key from any screen displays helpful information about that screen. From the menu screen, general help information is displayed as to how to use the user interface. To return to the previous screen press the Help or Select keys, or press Menu key to go to the menu screen. If a small down arrow appears in the lower right hand corner then there is off screen content below what is displayed. Press the down arrow to scroll down to this information. After scrolling down an up arrow will appear in the upper right hand corner to indicate off screen content above what is displayed.

UIM LED's

The three LED's to the right of the LCD indicate the status of the overall system. The red LED indicates that a fault has been detected and the system has stopped running. It is on continuously for soft faults and flashes for hard faults. The Yellow LED indicates that the boiler is in a ready mode waiting for a call for heat command. When on continuously the Green LED indicates that the system is in the heating mode. If it is flashing it indicates that the UIB is in the initialization mode when the touch switches are being calibrated.

On multiple stage boilers there are also eight LED's on the lower right that indicate the state of the individual FCB's. The red LED's are only on when the main red LED is on and indicate which FCB has the error. The green LED indicates when flame is proved on that particular stage, unless the dipswitch for sensing flame is turned off. Then the LED indicates that the gas valve has turned on.

Fault Messages and Troubleshooting Guide

The EMC5000 system does excessive self-diagnostics and displays detected faults on the UIM display in an easy to read manner. There are approximately 80 different faults that can be detected. Some of the faults are caused by internal problems and some by external causes. The faults create different types of system lockouts (shut down). Hard lockouts are serious problems that require the user to manually restart the system. Soft lockouts can be reset by the user or after 60 minutes the system will automatically clear the error and restart. Auto Reset lockouts will monitor the cause of the fault and if the fault clears itself the system resets itself. Faults with Immediate Reset lockouts are caused by faults that are momentary in nature. The fault is recorded and the system immediately resets itself. The following table shows the fault messages and some possible troubleshooting hints:

TROUBLESHOOTING IGNITION SYSTEM

Fault Messages and Lockout Status (* = stage number: 1 or 2)

Fault Displayed	Description	Red LED	Lockout
"Display Fail"	Communications with UIM interrupted • Check communication cable to UIM. Try moving to other Internal Communications connector on CCB. Also check the connectors where the cable is plugged in for best connecting wires.	Continuous	Auto Reset
"Comm. Fail Stg.*"	Communications with FCB interrupted • Same as above. Also try swapping FCB and UIM communications cables.	Continuous	Auto Reset
"Low AC Voltage"	Line voltage less than 90 vac • Check incoming power line for loss of voltage. May also be caused by a power line brown-out (momentary loss of voltage)	Continuous	Auto Reset
"Low 24VAC"	Voltage from transformer less than 18 vac • Check transformer output. Should be over 24vac. May be caused by excessive current drain or a faulty transformer	Continuous	Auto Reset
"Brown Out Reset"	Indicates a brown out reset occurred • Caused by a momentary dip in voltage on the CCB +5vdc power bus. Contact factory. (Not considered a serious problem if it only occurs on very rare occasions.)	---	None
"Timeout Reset"	Indicates a watchdog reset occurred • Caused when the micro executes the software in an improper way. Contact factory. (Not considered a serious problem if it only occurs on very rare occasions.)	---	None
"CCB Overflow"	Stack overflow - recorded in history only • Caused when the micro overfills its memory stack. Contact factory. (Not considered a serious problem if it only occurs on very rare occasions.)	---	Immediate Reset
"CCB Underflow"	Stack underflow - recorded its history only • Caused when the micro underfills its memory stack. Contact factory. (Not considered a serious problem if it only occurs on very rare occasions.)	---	Immediate Reset
"Sequence Err"	Incorrect flow of critical code • Caused when the micro executes software code in an incorrect manner. Contact factory.	Flashing	HARD
"A/D Fail CCB"	Error in analog input reading • Caused when the Analog to Digital converter section of the micro operates improperly. Contact factory.	Flashing	HARD
"EEProm Error"	Not implemented	---	None
"ROM Failure Stg**"	ROM contents incorrect • Caused when the Read Only Memory on one of the FCB micros operates improperly. Contact factory.	Flashing	HARD

“ROM Failure CCB”	ROM contents incorrect	Flashing	HARD
	• Caused when the Read Only Memory on the CCB micro operates improperly. Contact factory.		
“Hdwr Short Stg**	FCB output pin shorted	Flashing	HARD
	• Caused when a pin on one of the FCB micros is not in the output state it should be in. Contact factory.		
“Hdwr Short CCB”	CCB output pin shorted	Flashing	HARD
	• Caused when a pin on the CCB micro is not in the output state it should be in. Contact factory.		
“CPU Fail Stg**	FCB processor failed internal check	Flashing	HARD
	• Caused when one of the FCB micros does not pass its internal checks. Contact factory.		
“CPU Fail CCB”	CCB processor failed internal check	Flashing	HARD
	• Caused when the CCB micro does not pass its internal checks. Contact factory.		
“RAM Failure CCB”	CCB Ram check failed	Flashing	HARD
	• Caused when the CCB micros Random Access Memory operates incorrectly. Contact factory.		
“FCB Comm Timeout”	FCB did not receive command from CCB	Continuous	SOFT
	• Caused when communications between the CCB and the FCB are interrupted. May occur when a surge of power on a nearby device (i.e. arc welder) creates an EMI burst. Not a serious problem if it occurs rarely.		
“No Flow”	Water is not flowing	Continuous	SOFT
	• Caused by the flow switch being open when it should be closed. Check water lines, pump, flow switch contacts, wiring.		
“Blower Prov Stg**”	blower pressure is too low	Continuous	SOFT
	• Caused by either the High-Speed or Low-Speed blower prover switches being open when they should have been closed. Check blowers, switch contacts, wiring, and for air leaks.		
“Blocked Flue”	Flue is Blocked	Continuous	SOFT
	• Caused by the blocked flue switch contacts being open when they should have been closed. Check for flue blockage, switch contacts, wiring.		
“High Limit”	Outlet temp. exceeded high limit setpoint	Continuous	Auto Reset
	• Caused when the temperature of the outlet probe exceeds the high limit setpoint. This is an internal “software” limit switch and not an actual device. Check that the over temperature is not being caused by improper setup or operation of the boiler.		
“MRHL fault”	Outlet temp is too high	Flashing	HARD
	• Caused when the Manual Reset High Limit contacts in the Outlet probe are open when they should be closed. Fault may be due to high outlet temperature, bad switch contacts in the Manual Reset High Limit, or disconnected wiring. Note: The Manual Reset High Limit can be checked by disconnecting the outlet probe from the CCB and reading the resistance across the two active pins on the connector at the end of the probe cable. The value should be approximately 0 ohms when the temperature of the probe is less than 220°F.		
“Low Water”	Water level is too low	Flashing	HARD
	• Caused by the Low Water Cut Out device not closing its feedback switch contacts when it should. Check water line, switch contacts, wiring, LWCO.		
“Low Gas”	Gas pressure is too low	Flashing	HARD
	• Caused by the Low Gas switch being open when it should be closed. Check gas line, switch contacts, wiring.		
“IRI Gas”	IRI Gas Valve did not turn on	Flashing	HARD
	• Caused by the IRI Gas Valve not closing its feedback switch contacts when it should. Could also be caused by a problem with the relay output on the CCB. Check output to IRI Gas Valve, switch contacts, wiring.		
“Powered Vent”	Power vent not running	Flashing	HARD
	• Caused by the Powered Vent device not closing its feedback switch contacts when it should. Could also be caused by a problem with the relay output on the CCB. Check output to powered vent, switch contacts, wiring.		
“High Gas Stg*”	Gas pressure too high	Flashing	HARD
	• Caused by the High Gas switch being open when it should be closed. Check gas line, switch contacts, wiring.		
“Inlet Probe”	Inlet probe shorted or open	Flashing	HARD
	• Caused when the thermistor in the probe or the wiring to the probe is shorted or disconnected. Check the probe. Note: The thermistor and wiring can be checked by disconnecting the probe from the CCB and reading the resistance across the two active pins on the connector at the end of the probe cable. The value should be approximately 10K ohms (value will change slightly with changes in temperature).		
“Outlet Probe:”	Outlet probe shorted or open	Flashing	HARD
	• Caused when the thermistor in the probe or the wiring is shorted or disconnected. Check the probe. Note: the thermistor and wiring can be checked by disconnecting the probe from the CCB and reading the resistance across the two active pins on the connector at the end of the probe cable. The value should be approximately 10K ohms		

(value will change slightly with changes in temperature).

"Tank Probe"	Tank (Remote) probe shorted or open	Flashing	HARD
	<ul style="list-style-type: none">Caused when the thermistor in the probe or the wiring is shorted or disconnected. Check the probe. Note: the thermistor and wiring can be checked by disconnecting the probe from the CCB and reading the resistance across the two active pins on the connector at the end of the probe cable. The value should be approximately 10K ohms (value will change slightly with changes in temperature).		
"Igniter Stg*"	Igniter current is too low	Flashing	HARD
	<ul style="list-style-type: none">Caused by a low current draw problem with the igniter. This may occur if the igniter is old, damaged, or disconnected and no longer draws the proper level of current. This condition will affect the ability of the igniter to get hot enough to fire the gas properly. Check the igniter and its associated wiring.		
"Igniter Pwr Stg*"	Improper power applied to igniter circuit	Flashing	HARD
	<ul style="list-style-type: none">Caused by improper line power being applied to the igniter circuitry. Check line connections. Paying particular attention to the earth ground connection. Also check that line voltage does not exceed 132 vac rms.		
"Igniter Hdwr Stg*"	Hardware problems with igniter circuit	Flashing	HARD
"Gas Relay Stg*"	Gas Valve Relays did not turn on	Flashing	HARD
"Flame Stg*"	Flame not detected	Flashing	HARD
"Blwr Low Stg*"	Low speed blower relay did not turn on	Flashing	HARD
	<ul style="list-style-type: none">Caused by a failure of a relay on the FCB. Contact factory.		
"Blwr Hi Stg*"	High speed blower relay did not turn on	Flashing	HARD
	<ul style="list-style-type: none">Caused by a failure of a relay on the FCB. Contact factory.		
"Short Cycle Cond."	Burner cycle rate above 30 per hour	SEE BELOW	----
	<ul style="list-style-type: none">Caused when a stage performs more than 30 heat cycles in one hour. When this fault is detected the system continues to operate but the calls for heat are forced to occur no faster than every 180 seconds. While this system is in this short cycle operating mode the yellow "Standby" LED flashes. Check system setup and operation.		

Other troubleshooting hints:

1. Input switches can be easily checked by observing their activation on the UIM System Status screen. Force the boiler to remain in the Standby mode by opening the Thermostat input or by setting the operating setpoint to the minimum so that the system does not request heat. Then short out the contacts on the switch and verify that an asterisk "*" appears next to the appropriate input on the screen. If it does not then look for the problem to be in the wiring or connectors between the switch and the CCB.
2. When troubleshooting a particular problem the heating sequence time can be shortened by turning off the dipswitches for operation devices that are not needed during troubleshooting.
3. The pump can be activated during the "Standby" mode by changing the post-circulate time too continuous.
4. All Hi-Speed blowers can be activated for 5 minutes by opening any Hi-Speed blower prover switch prior to turning on the power. This activates the "shutter adjust" mode. During this time, activation of all of the blower prover switches can be checked on the "system status" screen.
5. Opening the Thermostat input leads will force the system to remain in the standby mode.
6. Running the system with the gas turned off will allow the system to run through all operating steps up to flame sensing.
7. Proper operation of the flame sensing circuit can be almost completely verified through the use of a 14007 diode. The anode end of the diode should be connected to the appropriate flame sense lead and the cathode end (bar) of the diode should be connected to the case of the boiler (earth ground connection). Gas is not needed for this procedure and therefore should be off. It is also desirable to disable the command for heat by opening the thermostat leads. After apply power the system should declare an error because flame is being sensed at the wrong time. Shift to the "System Status" screen and scroll down to the appropriate "Flame" input. The asterisk "*" should appear when the diode is connected and not when it is disconnected.
8. The CCB can be individually checked out by setting the 10 position CCB dipswitch to off. This will make the system operate as a single stage and disable the other FCB's.
9. Watching the Control States screen while troubleshooting the heating sequence will help determine what is causing the problem. Knowing what state the CCB and FCB's are in when the problem occurs will help to pinpoint a possible source of the fault.
10. Write down the proper positions of the dip switches after initial installation and compare them to the present dipswitch setting shown on the "Configuration Settings" screen. This will catch any accidental changing of the dipswitches.

! DANGER

HOT WATER TEMPERATURES REQUIRED FOR AUTOMATIC DISHWASHER AND LAUNDRY USE CAN CAUSE SCALD BURNS RESULTING IN SERIOUS PERSONAL INJURY AND/OR DEATH. THE TEMPERATURE AT WHICH INJURY OCCURS VARIES WITH THE PERSON'S AGE AND TIME OF EXPOSURE. THE SLOWER RESPONSE TIME OF CHILDREN, AGED OR DISABLED PERSONS INCREASES THE HAZARDS TO THEM. NEVER ALLOW SMALL CHILDREN TO USE A HOT WATER TAP, OR TO DRAW THEIR OWN BATH WATER. NEVER LEAVE A CHILD OR DISABLED PERSON UNATTENDED IN A BATHTUB OR SHOWER.



THE WATER HEATER SHOULD BE LOCATED IN AN AREA WHERE THE GENERAL PUBLIC DOES NOT HAVE ACCESS TO SET TEMPERATURES.

IT IS RECOMMENDED IN DOMESTIC HOT WATER APPLICATIONS THAT LOWER WATER TEMPERATURES BE USED TO AVOID THE RISK OF SCALDING. IT IS FURTHER RECOMMENDED, IN ALL CASES, THAT THE WATER TEMPERATURE BE SET FOR THE LOWEST TEMPERATURE WHICH SATISFIES THE USER'S HOT WATER NEEDS. THIS WILL ALSO PROVIDE THE MOST ENERGY EFFICIENT OPERATION OF THE BOILER AND MINIMIZE SCALE FORMATION IN THE HEAT EXCHANGER, THUS PROLONGING THE LIFE OF THE BOILER.

SETTING THE WATER HEATER TEMPERATURE AT 120°F (49°C) WILL REDUCE THE RISK OF SCALDS. SOME STATES/PROVINCES REQUIRE SETTINGS AT SPECIFIC LOWER TEMPERATURES. TABLE 1 BELOW SHOWS THE APPROXIMATE TIME-TO-BURN RELATIONSHIP FOR NORMAL ADULT SKIN.

TABLE 1. Risk of Scalds

Water Temperature	Time to Produce 2nd & 3rd Degree Burns on Adult Skin
Over 170°F (77°C)	Nearly instantaneous
160°F (71°C)	About 1/2 second
150°F (66°C)	About 1-1/2 seconds
140°F (60°C)	Less than 5 seconds
130°F (54°C)	About 30 seconds
120°F (49°C) or less	More than 5 minutes

USE ANTI-SCALD VALVE(S) in the hot water system to reduce the risks of scalding at points of use such as lavatories, sinks and bathing facilities.

MAIN BURNERS

Check main burners every three months for proper flame characteristics. The main burner should display the following characteristics:

- Provide complete combustion of gas.
- Cause rapid ignition and carry over of flame across entire burner.
 - Give reasonably quiet operation during initial ignition, operation and extinction.
 - Cause no excessive lifting of flame from burner ports; see Figure 7.

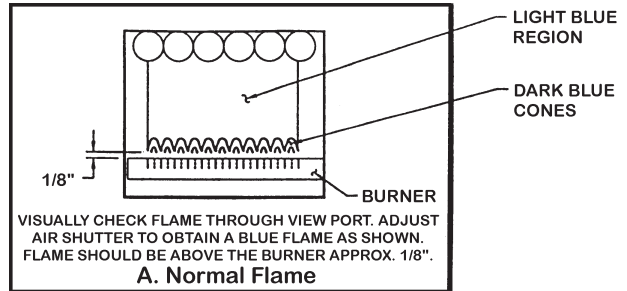

FIGURE 7. BURNER FLAME CHARACTERISTICS

If the preceding burner characteristics are not evident, check for accumulation of lint or other foreign material that restricts or blocks the air openings to the burner or boiler.

NOTE: Cleaning of main burners.

1. Shut off all gas and electricity to unit per Light and Operating Instructions. Allow boiler to cool.
2. Remove main burners from unit.
3. Check that burner venturi and ports are free of foreign matter.
4. Clean burners with bristle brush and/or vacuum cleaner. DO NOT distort burner ports.
5. Reinstall burners in unit. Ensure that all the screws on the burner flange are tightened securely so that the gasket will provide a good seal. Also, ensure that each orifice is centered with the venturi opening of every burner.

Note: Make sure the washer of each pre-jet orifice is inserted at least 1/4 into the burner tube and that it is not touching the sides of the burner tube. This is critical for proper operation, see Figure 8.

6. Check for good flow of combustion and ventilating air to the unit.

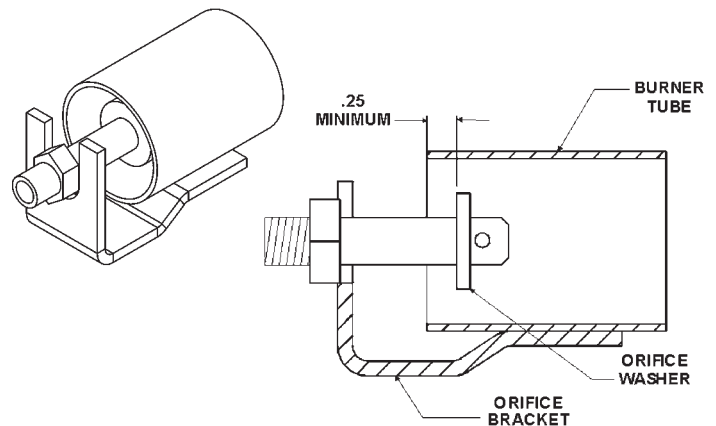

FIGURE 8. BURNER/ORIFICE INSERTION

After placing the boiler in operation, check the ignition system safety shut-off devices for proper operation. To accomplish this with the main burners operating, close the valve on the manifold. Within four seconds the main burners should extinguish. If this does not occur immediately, discontinue gas supply by closing main manual shut-off and call a qualified serviceman to correct the situation. If the burners extinguish, then light boiler in accordance with lighting and operating instructions.

For installations above 4500 feet (1350 m), refer to HIGH ALTITUDE INSTALLATIONS in the Installation Manual.

DO NOT STORE COMBUSTIBLE MATERIALS, GASOLINE, OR OTHER FLAMMABLE VAPORS, LIQUIDS IN THE AREA OF THE APPLIANCE. NONCOMPLIANCE MAY RESULT IN FIRE OR EXPLOSION. DO NOT OBSTRUCT THE FLOW OF COMBUSTION OR VENTILATION AIR TO THE APPLIANCE.

CHEMICAL VAPOR CORROSION

Boiler corrosion and component failure can be caused by airborne chemical vapors. Spray can propellants, cleaning solvents, refrigerants, calcium or sodium chloride (water softener salts), waxes, chlorine and process chemicals are typical compounds that are potentially corrosive. These materials are corrosive at very low concentration levels with little or no odor to reveal their presence. Products of this sort should not be stored near the boiler. Air which is brought in contact with the boiler should not contain any of these chemicals. The boiler should be provided with air from outdoors when installed in environments having corrosive atmospheres.

CIRCULATION PUMP

Refer to the pump manufacturer's schedule of maintenance for frequency and method of lubricating the pump and motor. Inspect the pump once a month for leaky mechanical seals and/or O-rings and loose or damaged components. Contact a qualified service agent to replace or repair parts as required.

BLOCKED VENT SHUT-OFF SYSTEM

The boiler is equipped with a blocked vent shut-off system which will close the gas valve and shut off the main burner gas when there is excessive pressure pressuring the vent system due to a partially or completely blocked vent. The display on the front panel will indicate this failure condition.

DO NOT ATTEMPT TO OPERATE THE BOILER if this situation occurs. Shut the boiler off before performing all the steps shown in "TO TURN OFF GAS TO APPLIANCE" section of the Lighting and Operating Instructions.

Contact a qualified service agent to inspect the unit and vent system and correct the problem.

VENT SYSTEM

The flue products are corrosive in nature and if the boiler is vented horizontally the flue gases are at a higher pressure than the surrounding air pressure. Inspection of the boiler and vent system is necessary to insure that flue gas leakage to the surrounding area does not occur.

Inspect the external surfaces of the vent system every 6 months for corrosion and leakage. Inspect the vent terminations for corrosion and foreign matter (including ice) which may be blocking the exhausting flue products. Call a qualified service agent to replace or repair any corroded or leaking parts.

Qualified service agent must inspect internal surfaces of the vent system and the boiler at least once a year.

DELIMING

The amount of calcium carbonate (lime) released from water is in direct proportion to water temperature and usage. The higher the water temperature or water usage, the more lime deposits are dropped out of the water. This is the lime scale which forms in pipes, boilers and on cooking utensils.

The usage of water softening equipment greatly reduces the hardness of water. However, this equipment does not always remove all of the hardness (lime). For this reason it is recommended that a regular schedule for deliming be maintained.

The time between cleaning will vary from two to six months depending upon water conditions and usage. A change of approximately 5°F (3°C) in the normal temperature rise through the boiler is usually an indication that scale should be removed. For long life, copper or brass is recommended for all valves, pipe and fittings.

⚠ CAUTION

LIME ACCUMULATION CAN REDUCE THE LIFE OF THE EQUIPMENT, REDUCE EFFICIENCY AND WASTE FUEL. BOILER FAILURE DUE TO LIME OR SCALE BUILDUP VOIDS THE WARRANTY.

COMBUSTION AIR BLOWER

The bearings in the motor are pre-lubricated and sealed at the factory. The bearings should be oiled once every six months per the manufacturer's recommended maintenance schedule. Use SAE-29 non-detergent oil.

RELIEF VALVE

The safety relief valve should be opened at least twice a year to check its working condition. This will aid in assuring proper pressure relief protection. Lift the lever at the top of the valve several times until the valve seats properly and operates freely.

⚠ DANGER

THE WATER PASSING OUT OF THE VALVE DURING CHECKING OPERATION MAY BE EXTREMELY HOT. BEFORE OPERATING RELIEF VALVE, MAKE SURE DRAIN LINE IS INSTALLED TO DIRECT DISCHARGE TO A SAFE LOCATION SUCH AS AN OPEN DRAIN, TO AVOID SCALDING OR WATER DAMAGE.

⚠ WARNING

SHOULD OVERHEATING OCCUR OR THE GAS SUPPLY FAIL TO SHUT OFF, TURN OFF THE MANUAL GAS CONTROL VALVE TO THE APPLIANCE.

NOTES

NOTES

NOTES

NEW BOILER LIMITED WARRANTY

A. O. Smith Corporation, the warrantor, extends the following LIMITED WARRANTY to the owner of this hydronic boiler:

1. If within TEN years after initial installation of the boiler, the heat exchanger shall prove upon examination by the warrantor to be defective in material or workmanship, the warrantor, at his option, will exchange or repair such part or portion. This term is reduced to FIVE years if this boiler is used for volume hot water supply purposes other than hydronic space heating.
 - a. This warranty is extended to the owner for all other parts or portion during the FIRST year following initial installation of this boiler.
 - b. The warranty on the repair or replacement of the part or portion will be limited to the unexpired term of the original warranty.
2. **CONDITIONS AND EXCEPTIONS**

This warranty shall apply only when the boiler is installed in accordance with local plumbing and building codes, ordinances and regulations, the printed instructions provided with it and good industry practices. In addition, an appropriately sized safety relief valve certified to the ASME Boiler and Pressure Vessel Code must have been installed and fresh water used for filling and makeup purposes;

 - a. This warranty shall apply only when the boiler is used:
 - (1) at temperatures not exceeding the maximum setting of its operative and/or high limit control;
 - (2) at water pressure not exceeding the working pressure shown on the boiler;
 - (3) when filled with boiler water, free to circulate at all times and with the heat exchanger free of damaging scale deposits;
 - (4) in a noncorrosive and non-contaminated atmosphere;
 - (5) in the United States, its territories or possessions, and Canada;
 - (6) at a water velocity flow rate, not exceeding or below the Boiler's designed flow rates;
 - b. Any accident to the boiler, any misuse, abuse (including freezing) or alteration of it, any operation of it in a modified form will void this warranty.
3. **SERVICE AND REPAIR EXPENSE**

Under this limited warranty the warrantor will provide only a replacement part. The owner is responsible for all other costs. Such costs may include but are not limited to:

 - a. Labor charges for service removal, repair or reinstallation of the component part;
 - b. Shipping, delivery, handling, and administrative charges for forwarding the replacement part from the nearest distributor and returning the claimed defective part to such distributor.
 - c. All cost necessary or incidental for any material and/or permits required for installation of the replacement.
4. **LIMITATIONS ON IMPLIED WARRANTIES**

Implied warranties, including any warranty of merchantability imposed on the sale of this boiler under state law are limited to one (1) year duration for the boiler or any of its parts. Some states or provinces do not allow limitations on how long an implied warranty lasts, so the above limitation may not apply to you.
5. **CLAIM PROCEDURE**

Any claim under the warranty should be initiated with the dealer who sold the boiler, or with any other dealer handling the warrantor's products. If this is not practical, the owner should contact:

U.S. Customers

A. O. Smith Water Products Company
500 Tennessee Waltz Parkway
Ashland City, TN 37015
Telephone: 800-323-2636

Canadian Customers

A. O. Smith Enterprises Ltd.
P. O. Box, 310 - 768 Erie Street
Stratford, Ontario N5A 6T3
Telephone: 800-265-8520

- a. The warrantor will only honor replacement with identical or similar parts thereof which are manufactured or distributed by the warrantor.
 - b. Dealer replacements are made subject to in-warranty validation by warrantor.
6. **DISCLAIMERS**

NO OTHER EXPRESS WARRANTY HAS BEEN OR WILL BE MADE ON BEHALF OF THE WARRANTOR WITH RESPECT TO THE MERCHANTABILITY OF THE BOILER OR THE INSTALLATION, OPERATION, REPAIR OR REPLACEMENT OF THE BOILER. THE WARRANTOR SHALL NOT BE RESPONSIBLE FOR WATER DAMAGE, LOSS OF USE OF THE UNIT, INCONVENIENCE, LOSS OR DAMAGE TO PERSONAL PROPERTY OR OTHER CONSEQUENTIAL DAMAGE. THE WARRANTOR SHALL NOT BE LIABLE BY VIRTUE OF THIS WARRANTY OR OTHERWISE FOR DAMAGE TO ANY PERSONS OR PROPERTY, WHETHER DIRECT OR INDIRECT, AND WHETHER ARISING IN CONTRACT OR TORT.

 - a. Some states or provinces do not allow the exclusion or limitation of the incidental or consequential damage, so the above limitations or exclusions may not apply to you.
 - b. This warranty gives you specific legal rights, and you may also have other rights which vary from state to state or province to province.

Fill in the following for your own reference. Keep it. Registration is not a condition of warranty. The model and serial number are found on the boiler's rating plate.

Owner _____

Installation Address _____

City and State or Province _____

Date Installed _____ Model No. _____ Serial No. _____

Dealer's Name _____

Dealer's Address _____ Phone No. _____

FILL IN WARRANTY AND KEEP FOR FUTURE REFERENCE



25589 Highway 1, McBee, SC 29101
Technical Support: 800-527-1953 • Parts: 800-433-2545 • Fax: 800-644-9306
www.hotwater.com