



MODELS DB/DW-720-1810

**NATURAL GAS-FIRED COMMERCIAL CROSS FLOW COPPER BOILERS
FOR HYDRONIC HEATING AND HOT WATER SUPPLY**

**WITH ELECTRONIC INTERMITTENT PILOT IGNITION AND
LINEAR-TEMP® INSTALLATIONS** A. O. SMITH **Cer-Temp 80®**
RECOVERY SYSTEM

- **INSTALLATION • OPERATION • MAINTENANCE • LIMITED WARRANTY**



WARNING: If the information in this manual is not followed exactly, a fire or explosion may result causing property damage, personal injury or loss of life.

- Do not store or use gasoline or other flammable vapors and liquids in the vicinity of this or any other appliance.
- **WHAT TO DO IF YOU SMELL GAS**
 - Do not try to light any appliance.
 - Do not touch any electrical switch; do not use any phone in your building.
 - Immediately call your gas supplier from a neighbor's phone. Follow the gas supplier's instructions.
 - If you cannot reach your gas supplier, call the fire department.
- Installation and service must be performed by a qualified installer, service agency or the gas supplier.



CAUTION
TEXT PRINTED OR OUTLINED IN RED CONTAINS INFORMATION RELATIVE TO YOUR SAFETY. PLEASE READ THOROUGHLY BEFORE INSTALLING AND USING THIS APPLIANCE.

A. O. SMITH
WATER PRODUCTS
COMPANY

A DIVISION OF A.O. SMITH CORPORATION
EL PASO, TX McBEE, SC RENTON, WA
STRATFORD, ONTARIO
VELDHOVEN, THE NETHERLANDS
www.hotwater.com

PLACE THESE INSTRUCTIONS ADJACENT TO BOILER AND
NOTIFY OWNER TO KEEP FOR FUTURE REFERENCE.

	Page
FOREWORD	2
REPLACEMENT PARTS	2-3
ROUGH-IN DIMENSIONS/CAPACITIES	3-4
Installation Clearances	3
Levelling	3
FEATURES	5

FOREWORD



CAUTION

TEXT PRINTED OR OUTLINED IN RED CONTAINS INFORMATION RELATIVE TO YOUR SAFETY. PLEASE READ THOROUGHLY BEFORE USING APPLIANCE.

Detailed installation diagrams are in this manual. These diagrams will serve to provide the installer with a reference for the materials and method of piping suggested. **IT IS NECESSARY THAT ALL WATER AND GAS PIPING AND THE ELECTRICAL WIRING BE INSTALLED AND CONNECTED AS SHOWN IN THE DIAGRAMS.**

CHECK THE DIAGRAMS THOROUGHLY BEFORE STARTING INSTALLATION TO AVOID POSSIBLE ERRORS AND TO MINIMIZE TIME AND MATERIALS COST.

This design complies with the latest edition of the ANSI Z21.13 CSA 4.9 low-pressure boiler.

Particular attention should be given to the installation of thermometers at the locations indicated in the diagrams as these are necessary for checking the operation of the boiler.

MAKE SURE THE GAS ON WHICH THE BOILER WILL OPERATE IS THE SAME AS THAT SPECIFIED ON THE UNIT RATING PLATE.

The boiler installation must conform to these instructions and the requirements of the local authority having jurisdiction.

Where required by the authority having jurisdiction, the installation must conform to the Standard for Controls and Safety Devices for Automatically Fired Boilers, ANSI/ASME CSD-1.

In the absence of local code requirements, the boiler installation must conform to the most current National Fuel Gas Code, ANSI Z223.1 and/or CAN/CSA-B149.1-00 installation codes.

These manuals can be purchased from the CSA International, 8501 East Pleasant Valley Road, Cleveland, OH 44131 or 178 Rexdale Boulevard, Toronto, Ontario Canada, M9W 1R3.

REPLACEMENT PARTS

Replacement parts may be ordered through A. O. Smith dealers, authorized servicers or distributors. Refer to the Yellow Pages for where to call or contact (in United States) the A.O. Smith Water Products Company, 5621 West 115th Street, Alsip, IL 60803, 1-800-433-2545 or (in Canada) A.O. Smith Enterprises Ltd., 768 Erie Street, Stratford, Ontario, Canada N5A 6T3, 800-265-8520. When ordering parts be sure to state the quantity, part number and description of the item including the complete model and serial number as it appears on the product. Refer to the parts lists for more information.

For Technical Assistance call A.O. Smith Technical Information Center at 1-800-527-1953.



WARNING

THE INLET/OUTLET WATER MANIFOLD ON YOUR A. O. SMITH UNIT INCORPORATES AN "O RING" WATER SEAL ASSEMBLY. THE MANIFOLD IS NOT DESIGNED TO SUPPORT THE WEIGHT OF THE WATER PIPING SYSTEM. AS ON ALL BOILER INSTALLATIONS, SPECIAL CARE MUST BE TAKEN TO ENSURE PROPER SUPPORT.



WARNING

UNDER NO CIRCUMSTANCES SHOULD THE EQUIPMENT ROOM WHERE THE BOILER IS INSTALLED EVER BE UNDER NEGATIVE PRESSURE. PARTICULAR CARE MUST BE TAKEN WHEN EXHAUST FANS, COMPRESSORS, AIR HANDLING EQUIPMENT, ETC., MAY INTERFERE WITH THE COMBUSTION AND VENTILATION AIR SUPPLIES OF THIS BOILER.



CAUTION
Label all wires prior to disconnection when servicing controls. Wiring errors can cause improper and dangerous operation.

"Verify proper operation after servicing."

ROUGH-IN DIMENSIONS/ CAPACITIES

INSTALLATION CLEARANCES

These boilers are approved for installation on combustible flooring in an alcove with minimum clearance to combustibles. See chart below.

Two inch clearance is allowable from combustible construction for hot water pipes.

Sufficient clearance should be provided at one end of the boiler to permit access to heat exchanger tubes for cleaning. Maximum operating water supply pressure 160 psi. Gas supply pressure: 13.8" w.c. max., 5.5" w.c. min.

Sufficient area should be provided at the front and sides of the unit for proper servicing. Clearances of 48" in front and 24" on sides is recommended. In a utility room installation, the door shall be wide enough to allow the boiler to enter or to permit the replacement of another appliance.

LEVELLING

Each unit should be checked after installation to be certain that it is level.

WARNING
AN AMPLE SUPPLY OF AIR MUST BE PROVIDED FOR PROPER COMBUSTION AND VENTILATION.



TABLE 1, ROUGH-IN DIMENSIONS

Models	DW-720		DW-840		DW-960		DW-1080		DW-1210		DW-1350		DW-1480		DW-1610		DW-1810	
	inches	mm	inches	mm	inches	mm	inches	mm	inches	mm	inches	mm	inches	mm	inches	mm	inches	mm
A	46 1/2	1181	52 1/5	1326	57 3/4	1467	52 7/8	1343	58 1/2	1486	64 1/2	1638	69 1/2	1765	75	1905	82 1/2	2096
B	29 5/8	752	29 5/8	752	29 5/8	752	32 3/4	832	32 3/4	832	32 3/4	832	34	864	34	864	34	864
C	54 3/4	1391	54 3/4	1391	54 3/4	1391	58	1473	58	1473	58	1473	60 1/2	1537	60 1/2	1537	60 1/2	1537
D	1 1/4 NPT		1 1/4 NPT		1 1/4 NPT		1 1/4 NPT		1 1/2 NPT		1 1/2 NPT		1 1/2 NPT		2 NPT		2 NPT	
E	7 3/4	197	7 3/4	197	7 3/4	197	7 1/2	191	7 1/2	191	7 1/2	191	7 1/2	191	7 1/2	191	7 1/2	191
F	15 1/2	394	15 1/2	394	15 1/2	394	18 1/2	470	18 1/2	470	18 1/2	470	18 1/2	470	18 1/2	470	18 1/2	470
G	17 1/4	438	17 1/4	438	17 1/4	438	18 9/16	471	18 9/16	471	18 9/16	471	19 1/8	486	19 1/8	486	19 1/8	486
H	4 1/4	108	4 1/4	108	4 1/4	108	4	102	4	102	4	102	4 1/2	114	4 1/2	114	4 1/2	114
J	2 NPT		2 NPT		2 NPT		2 1/2 NPT		2 1/2 NPT		2 1/2 NPT		2 1/2 NPT		2 1/2 NPT		2 1/2 NPT	
K	2 NPT		2 NPT		2 NPT		2 1/2 NPT		2 1/2 NPT		2 1/2 NPT		2 1/2 NPT		2 1/2 NPT		2 1/2 NPT	
L	1 NPT		1 NPT		1 NPT		1 1/4 NPT		1 1/4 NPT		1 1/4 NPT		1 1/4 NPT		1 1/4 NPT		1 1/4 NPT	
M	12	305	14	356	14	356	16	406	16	406	18	457	18	457	18	457	20	508
N	15 1/2	394	16 1/2	419	16 1/2	419	17 1/4	438	17 1/4	438	17 1/4	438	13 3/4	349	13 3/4	349	13 3/4	349
W	32 1/8	816	31 1/8	791	32 1/8	816	30 15/16	786	30 15/16	786	30 15/16	786	31	787	31	787	31	787
Approx. Shipping Weight.	780 lbs	354 Kg	950 lbs	431 Kg	950 lbs	431 Kg	1000 lbs	454 Kg	1075 lbs	488 Kg	1100 lbs	499 Kg	1125 lbs	510 Kg	1150 lbs	522 Kg	1250 lbs	567 Kg

Minimum Clearances To Combustibles						
	Top	Water Side	Blank Side	Rear	Vent	Front
All Models	12" (305mm)	18" (457mm)	6" (155mm)	6" (155mm)	6" (155mm)	Alcove

FEATURES

IMPORTANT

Only qualified personnel shall perform the initial firing of the heater. At this time the user should not hesitate to ask the individual any questions regarding the operation and maintenance of the unit.

Lighting and Operating instructions are included at the rear of this manual. By using this checklist the user may be able to make minor operational adjustments and save unnecessary service calls. However, the user should not attempt repairs which are not listed under the USER column.

SAFETY RELIEF VALVES

Your local code authority may have other specific relief valve requirements not covered below.



WARNING

THE PURPOSE OF A SAFETY RELIEF VALVE IS TO AVOID EXCESSIVE PRESSURE WHICH MAY CAUSE TANK EXPLOSION, SYSTEM OR BOILER DAMAGE.

TO AVOID WATER DAMAGE A DRAIN LINE MUST BE CONNECTED TO A SAFETY RELIEF VALVE TO DIRECT DISCHARGE TO A SAFE LOCATION. A DRAIN LINE MUST NOT BE REDUCED FROM THE SIZE OF THE VALVE OUTLET AND IT MUST NOT CONTAIN ANY VALVES BETWEEN THE BOILER AND THE RELIEF VALVE OR THE RELIEF VALVE AND THE DRAIN EXIT. IN ADDITION, THERE SHOULD NOT BE ANY RESTRICTIONS IN A DRAIN LINE NOR SHOULD IT BE ROUTED THROUGH AREAS WHERE FREEZING CONDITIONS MIGHT OCCUR. DO NOT THREAD OR CAP THE DRAIN LINE EXIT. RESTRICTING OR BLOCKING A DRAIN LINE WILL DEFEAT THE PURPOSE OF THE RELIEF VALVE AND MAY CREATE AN UNSAFE CONDITION. INSTALL A DRAIN LINE WITH A DOWNWARD SLOPE SUCH THAT IT NATURALLY DRAINS ITSELF.

If any safety relief valve is replaced, the replacement valve must comply with the latest version of the ASME Boiler and Pressure Vessel Code, Section IV ("HEATING BOILERS"). Select a relief

AUTOMATIC RESET HIGH TEMPERATURE LIMIT CONTROL



LIMIT CONTROLS ARE NOT TO BE USED AS THERMOSTATS.

ALL MODELS - This limit is a safety device wired in series with the ignition system. Set the limit control dial to a minimum of 10°F (6°C) above the maximum designed system temperature. If the boiler outlet water temperature should exceed the high limit setting, the main gas valves will close but the circulator will continue to operate. Maximum adjustable setting is 240°F (116°C) for boilers and 200°F (93°C) for hot water supply heaters. The differential is adjustable from 5°F (3°C) to 45°F.

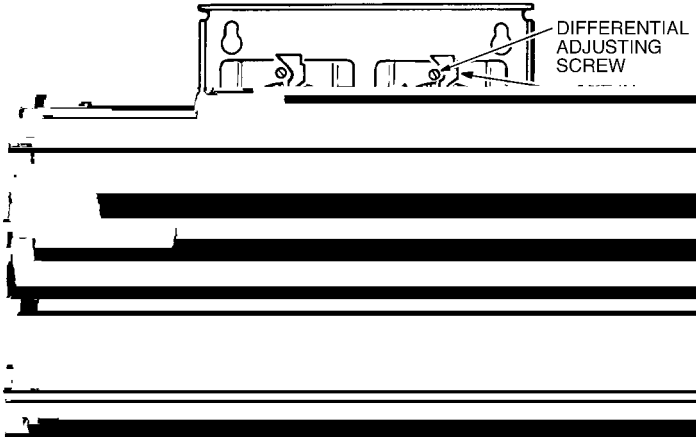

SINGLE STAGE AND MODULATING MODELS - Are equipped with the limit like the one shown in fig. 4.

Gas valves either close or open to full gas input, depending upon heat requirement.

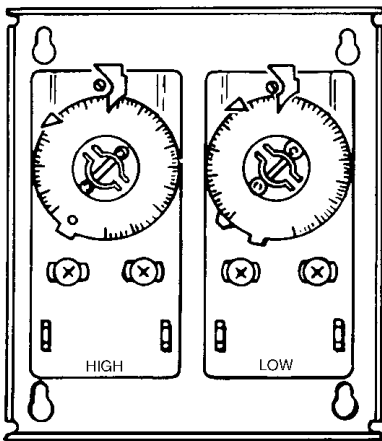

FIGURE 5

DUAL STAGE MODELS ONLY - HIGH/LOW OPERATOR

These boilers are factory equipped with a (combination) temperature controller to provide high and low firing rates for smooth operation. (fig. 5).

The temperature dials should be adjusted to have the HI dial set as a limit to be 10°F (6°C) above desired boiler temperature. These boilers are shipped with the HI dial set to 200°F (93°C) with a 15°F (8°C) differential, the LO dial set to 160°F (71°C) with a 10°F (6°C) differential.

The heater operation with above set points will be as follows:

- 1) When heater temperature rises to LO thermostat setting the main gas valve will close its second stage operator to drop input to approximately 50% of total input.
- 2) System conditions will determine if temperature rise at LO thermostat sensor location will continue to rise until shut-off by high limit or drop causing heater to go back to full input.

Other system design temperatures will require resetting of the dial. Total span of temperatures (HI dial cut-off point to LO dial cut-on point) should not be less than temperature drop of the system.

MODULATING MODELS ONLY

These boilers are factory equipped with a modulating gas valve that automatically controls the outlet water temperature by modulating or proportioning the rate of gas thus maintaining a desired constant outlet water temperature regardless of varying flow rates.

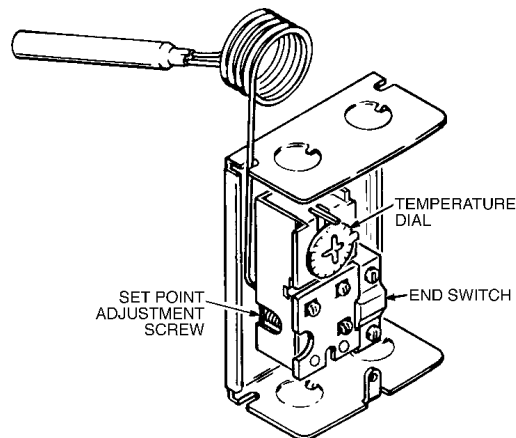

FIGURE 6

Set temperature controller for desired outlet water temperature. (fig. 6).

Adjust the set point for the desired operating temperature by turning the set point adjusting screw on the front of the case until the desired value is reached on the set point indicating dial. The set point is calibrated to be at the center of the proportioning range, (see the manufacturers instructions for complete information on testing and calibrating this control.)

THERMAL BALANCER

This device serves as a pump shutdown delay switch to balance the boiler water temperature to system temperature before the pump stops. Overshooting of boiler temperature is prevented and stack loss after shutdown is minimized.

SAFETY FLOW SWITCH

The safety flow switch is a safety device which must be installed at the water outlet of the unit to prevent main burner operation in the event of inadequate water flow through the boiler.

This switch may be mounted in a horizontal pipe line or a vertical pipe line with upward water flow. Do not install the switch where the water flow is downward.

INSTALLATION INSTRUCTIONS

REQUIRED ABILITY

INSTALLATION OR SERVICE OF THIS BOILER REQUIRES ABILITY EQUIVALENT TO THAT OF A LICENSED TRADESMAN IN THE FIELD INVOLVED. PLUMBING, AIR SUPPLY, VENTING, GAS SUPPLY AND ELECTRICAL WORK ARE REQUIRED.



WARNING

THE INLET/OUTLET WATER MANIFOLD ON YOUR A. O. SMITH UNIT INCORPORATES AN "O RING" WATER SEAL ASSEMBLY. THE MANIFOLD IS NOT DESIGNED TO SUPPORT THE WEIGHT OF THE WATER PIPING SYSTEM. AS ON ALL BOILER INSTALLATIONS, SPECIAL CARE MUST BE TAKEN TO ENSURE PROPER SUPPORT.

LOCATION

When installing the boiler, consideration must be given to proper location. Location selected should be as close to the stack or chimney as practical with adequate air supply and as centralized with the piping system as possible. This location should also be such that the gas ignition system components are protected from water (dripping, spraying, etc.) during appliance operation and service [circulator replacement, control replacement, etc.].

THE BOILER MUST NOT BE INSTALLED ON CARPETING.

THE BOILER SHOULD NOT BE LOCATED IN AN AREA WHERE IT WILL BE SUBJECT TO FREEZING.

LOCATE IT NEAR A FLOOR DRAIN. THE BOILER SHOULD BE LOCATED IN AN AREA WHERE LEAKAGE FROM THE BOILER OR CONNECTIONS WILL NOT RESULT IN DAMAGE TO THE ADJACENT AREA OR TO LOWER FLOORS OF THE STRUCTURE.

WHEN SUCH LOCATIONS CANNOT BE AVOIDED, A SUITABLE DRAIN PAN SHOULD BE INSTALLED UNDER THE BOILER. Such pans should be fabricated with sides at least 2-1/2" (64 mm) deep, with length and width at least 2" (51 mm) greater than the dimensions of the boiler and must be piped to an adequate drain.

The pan must not restrict combustion air flow.



WARNING

THERE IS A RISK IN USING FUEL BURNING APPLIANCES IN ROOMS OR AREAS WHERE GASOLINE, OTHER FLAMMABLE LIQUIDS OR ENGINE DRIVEN EQUIPMENT OR VEHICLES ARE STORED, OPERATED OR REPAIRED. FLAMMABLE VAPORS ARE HEAVY AND TRAVEL ALONG THE FLOOR AND MAY BE IGNITED BY THE IGNITER OR MAIN BURNER FLAMES CAUSING FIRE OR EXPLOSION. SOME LOCAL CODES PERMIT OPERATION OF GAS APPLIANCES IF INSTALLED 18 INCHES OR MORE ABOVE THE FLOOR. THIS MAY REDUCE THE RISK IF LOCATION IN SUCH AN AREA CANNOT BE AVOIDED.

FLAMMABLE ITEMS, PRESSURIZED CONTAINERS OR ANY OTHER POTENTIAL FIRE HAZARDOUS ARTICLES MUST NEVER BE PLACED ON OR ADJACENT TO THE BOILER.

OPEN CONTAINERS OF FLAMMABLE MATERIAL SHOULD NOT BE STORED OR USED IN THE SAME ROOM WITH THE BOILER.

If the boiler is installed above the level of heating system terminal units, a low water cutoff device must be installed in the boiler outlet at the time of installation.

For installation locations with elevations above 2,000 feet (610 M), refer to the HIGH ALTITUDE INSTALLATIONS section of this manual for input reduction procedure.

CHEMICAL VAPOR CORROSION

Heat exchanger corrosion and component failure can be caused by the heating and breakdown of airborne chemical vapors. Spray can propellants, cleaning solvents, refrigerator and air conditioning refrigerants, swimming pool chemicals, calcium and sodium chloride, waxes, and process chemicals are typical compounds which are corrosive. These materials are corrosive at very low concentration levels with little or no odor to reveal their presence.

Products of this sort should not be stored near the boiler. Also, air which is brought in contact with the water boiler should not contain any of these chemicals. If necessary, uncontaminated air should be obtained from remote or outside sources.

AIR REQUIREMENTS



WARNING

FOR SAFE OPERATION, AN AMPLE SUPPLY OF AIR MUST BE PROVIDED FOR PROPER COMBUSTION AND VENTILATION IN ACCORDANCE WITH SECTION 5.3, AIR FOR COMBUSTION AND VENTILATION, OF THE NATIONAL FUEL GAS CODE, ANSI Z223.1 OR 7.2, 7.3 OR 7.4 OF CAN/CSA B149.1-00, INSTALLATION CODES, OR APPLICABLE PROVISIONS OF THE LOCAL BUILDING CODES. AN INSUFFICIENT SUPPLY OF AIR MAY RESULT IN A YELLOW, LUMINOUS BURNER FLAME, CARBONING OR SOOTING OF THE FINNED HEAT EXCHANGER, OR CREATE A RISK OF ASPHYXIATION. DO NOT OBSTRUCT THE FLOW OF COMBUSTION AND VENTILATION AIR.

UNCONFINED SPACE

In buildings of conventional frame, brick or stone construction, unconfined spaces may provide adequate air for combustion, and draft hoalucium an dn bJ 0 -24 TD -0.0002 c -0.189 Tw (In8 the boiler

If the confined space is within a building of tight construction, air for combustion, ventilation, and draft hood dilution must be obtained from outdoors. When directly communicating with the outdoors or communicating with the outdoors through vertical ducts, two permanent openings, located in the aforementioned manner, shall be provided. Each opening shall have a free area of not less than one square inch per 4000 Btu/hr (551 mm² per kw) of the total input of all appliances in the enclosure. If horizontal ducts are used, each opening shall have a free area of not less than one square inch per 2000 Btu/hr (1101 mm² per kw) of the total input of all appliances in the enclosure.

(B) CANADIAN INSTALLATIONS

Ventilation of the space occupied by the boiler(s) shall be provided by an opening for ventilation air at the highest practical point communicating with outdoors. The total cross-sectional area shall be at least 10% of the area of the combustion air opening but in no case shall the cross-sectional area be less than 10 square inches (6500 mm²).

In addition to the above, there shall be permanent air supply opening(s) having a cross-sectional area of not less than 1 square inch per 7,000 BTUH (315 mm²/kw) up to and including 1,000,000 BTUH plus 1 square inch per 14,000 BTU (158 mm²/kw) in excess of 1,000,000 BTUH. This opening(s) shall be located at, or ducted to, a point neither more than 18" (450 mm) nor less than 6 inches (150 mm) above the floor level.

Where power vented equipment is used in the same room as the boiler, sufficient air openings must be supplied.

UNDERSIZED OPENINGS MAY RESULT IN INSUFFICIENT AIR FOR COMBUSTION.

Where an exhaust fan is installed in the same room with a boiler, sufficient openings for air must be provided in the walls. UNDERSIZED OPENINGS WILL CAUSE AIR TO BE DRAWN INTO THE ROOM THROUGH THE CHIMNEY, CAUSING POOR COMBUSTION. SOOTING MAY RESULT WITH AN INCREASED RISK OF ASPHYXIATION.

VENTING THE BOILER



THE INSTRUCTIONS IN THIS SECTION ON VENTING THE BOILER MUST BE FOLLOWED TO AVOID CHOKED COMBUSTION OR RECIRCULATION OF FLUE GASES. SUCH CONDITIONS CAUSE SOOTING OR RISKS OF FIRE AND ASPHYXIATION.

SINGLE WALL OR TYPE B VENTING MAY BE USED WITH THESE BOILERS. ALL LOCAL UTILITY, STATE/ PROVINCIAL, REGULATIONS ON VENTING MUST BE FOLLOWED.

VENT SIZING, INSTALLATION AND TERMINATION SHALL BE IN ACCORDANCE WITH PART 7, VENTING OF EQUIPMENT, OF THE NATIONAL FUEL GAS CODE, ANSI Z223.1, OR SECTION 7, VENTING SYSTEMS AND AIR SUPPLY FOR APPLIANCES, OF THE CAN/CSA B149, INSTALLATION CODES, OR APPLICABLE PROVISIONS OF THE LOCAL BUILDING CODES.

1. DRAFT HOOD

The integral draft hood, louvers or cabinetry must not be altered. Provision must be made if the boiler is installed in confined space or a small boiler room to accommodate draft hood spillage and avoid risks described above. The upper air opening called for in the AIR REQUIREMENTS section of this manual is for this purpose.

2. VENT CONNECTION

The minimum distance from adjacent public walkways, adjacent buildings, openable windows and building openings shall not be less than those values specified in the National Fuel Gas Code, ANSI Z223.1 and/or CAN/CSA B149.1-00, Installation Codes:

Stack or chimney must be a minimum height of 12" (305 mm) above the annual snow fall to prevent blockage.

Building materials must not come in contact with combustion products from stack or chimney, due to the degrading properties of flue products.

Materials may be protected from flue products by use of metal or copper sheeting.

Flue products must have a minimum clearance of 4 feet (1.22 m) horizontally from, and in no case above or below, unless a 4-foot (1.22 m) horizontal distance is maintained, from electric meters, gas meters, regulators and relief equipment.

The Canadian B149.1-00, Installation Code specifies a 6 foot horizontal vent terminal clearance to gas and electric meters and relief devices (this clearance is specified as 4 feet in the U.S. under the National Fuel Gas Code, ANSI/Z223.1). Therefore instruction provision 1.34.1-b19(d), which specifies compliance with the 4 foot clearance, as applies in the U.S. only, and the B149.1-00 Installation Code applies in Canada.

Vent connections must be made to an adequate stack or chimney and shall be in accordance with Part 7, Venting of Equipment, of the National Fuel Gas Code, ANSI Z223.1, or Section 7, Venting Systems and Air Supply for Appliances, of the CAN/CSA-B149.1-00, Installation Codes, or applicable provisions of the local building codes. Size and install proper size vent pipe. Do not reduce pipe size to less than that of the draft hood outlet unless permitted by local code.

Horizontal runs of vent pipe shall be securely supported by adequately placed (approximately every 4 feet [1.2 m]), noncombustible hangers suitable for the weight and design of the materials employed to prevent sagging and to maintain a minimum upward slope of 1/4" per foot (21mm/m) from the boiler to the vent terminals. Dampers or other obstructions must not be installed in the vent. Be sure that the vent connector does not extend beyond the inside wall of the chimney.

Where a continuous or intermittent back draft is found to exist the cause must be determined and corrected. A special vent cap may be required. If the back draft cannot be corrected by the normal methods or if a suitable draft cannot be obtained, a blower type flue gas exhauster may be employed to ensure proper venting and correct combustion (where permitted by local code). Contact your A. O. Smith dealer for power vent instructions.



WARNING

FAILURE TO CORRECT BACK DRAFTS MAY CAUSE AIR CONTAMINATION AND UNSAFE CONDITIONS.

Vent connectors serving appliances vented by natural draft shall not be connected into any portion of mechanical draft systems operating under positive pressure.

3. CONNECTING BOILER TO A COMMON VENT

Do not connect the boiler to a common vent or chimney with solid fuel burning equipment. This practice is prohibited by most local building codes as is the practice of venting gas fired equipment to the duct work of ventilation systems.

Where a separate vent connection is not available and the vent pipe from the boiler must be connected to a common vent with an oil burning furnace, the vent pipe should enter the common vent or chimney at a point ABOVE the flue pipe from the oil furnace.

UL/ULC listed doublewall type B-1 gas vents, through 24" (610 mm) diameter, can be installed in heated and unheated areas and can pass through floors, ceilings, partitions, walls and roofs, provided the required clearance is observed.

At the time of removal of an existing boiler, the following steps shall be performed with each appliance remaining connected to the common venting system. Perform these steps while the other appliances remaining connected to the common venting system are not in operation.

- Seal any unused openings in the common venting system.
- Visually inspect the venting system for proper size and horizontal pitch and determine there is not blockage or restriction, leakage, corrosion and other deficiencies which could cause an unsafe condition.
- Insofar as is practical, close all building doors and windows and all doors between the space in which the appliances remaining connected to the common venting system are located and other spaces of the building. Turn on clothes dryers and any appliance not connected to the common venting system. Turn on any exhaust fans, such as range hoods and bathroom exhaust fans, so they will operate at maximum speed. Close fireplace dampers.
- Place in operation the appliance being inspected. Follow the lighting instructions. Adjust thermostat so appliance will operate continuously.
- Test for spillage at the draft hood relief opening after five minutes of main burner operation. Use the flame of a match or candle, or smoke from a cigarette, cigar or pipe.
- After it has been determined that each appliance remaining connected to the common venting system properly vents when tested as outlined above, return doors, windows, exhaust fans, fireplace dampers and any other gas burning appliance to their previous conditions of use.

GAS CONNECTIONS



WARNING

THIS BOILER IS NOT INTENDED TO OPERATE AT GAS SUPPLY PRESSURE OTHER THAN SHOWN ON THE RATING PLATE. EXPOSURE TO HIGHER GAS SUPPLY PRESSURE MAY CAUSE DAMAGE TO GAS VALVES WHICH CAN RESULT IN FIRE OR EXPLOSION. IF OVERPRESSURE HAS OCCURRED SUCH AS THROUGH IMPROPER TESTING OF GAS LINES OR EMERGENCY MALFUNCTION OF THE SUPPLY SYSTEM, THE GAS VALVES MUST BE CHECKED FOR SAFE OPERATION. MAKE SURE THAT THE OUTSIDE VENTS ON THE SUPPLY REGULATORS AND THE SAFETY VENT VALVES ARE PROTECTED AGAINST BLOCKAGE. THESE ARE PARTS OF THE GAS SUPPLY SYSTEM, NOT THE BOILER. VENT BLOCKAGE MAY OCCUR DURING ICE BUILD-UP OR SNOW STORMS.

WHEN LOCAL CODES REQUIRE A MAIN MANUAL SHUTOFF VALVE OUTSIDE THE BOILER JACKET, A SUITABLE MAIN MANUAL SHUTOFF VALVE MUST BE INSTALLED IN A LOCATION COMPLYING WITH THOSE CODES.

IT IS IMPORTANT TO GUARD AGAINST GAS VALVE FOULING FROM CONTAMINANTS IN THE GAS WAYS. SUCH FOULING MAY CAUSE IMPROPER OPERATION, FIRE OR EXPLOSION.

IF COPPER SUPPLY LINES ARE USED THEY MUST BE APPROVED FOR GAS SERVICE.

BEFORE ATTACHING THE GAS LINE BE SURE THAT ALL GAS PIPE IS CLEAN ON THE INSIDE.

TO TRAP ANY DIRT OR FOREIGN MATERIAL IN THE GAS SUPPLY LINE, A DIRT LEG (SOMETIMES CALLED DRIP LEG OR SEDIMENT TRAP) UPSTREAM OF THE GAS CONTROLS, MUST BE INCORPORATED IN THE PIPING. The dirt leg must be readily accessible and not subject to freezing conditions. INSTALL IN ACCORDANCE WITH RECOMMENDATIONS OF SERVING GAS SUPPLIERS. REFER TO NATIONAL FUEL GAS CODE, ANSI Z223.1 AND/OR CAN/CSA-B149.1-00.

To prevent damage, care must be taken not to apply too much torque when attaching gas supply pipe to gas valve gas inlet.

Fittings and unions in the gas line must be metal to metal type.

Apply joint compounds (pipe dope) sparingly and only to the male threads of pipe joints. Do not apply compound to the first two threads. Use compounds resistant to the action of liquefied petroleum gases.

The boiler and its individual shutoff valve must be disconnected from the gas supply piping system during any pressure testing of that system at test pressures in excess of 1/2 psi (3.5 kPa).

The boiler must be isolated from the gas supply piping system by closing its individual manual shutoff valve during any pressure testing of the gas supply piping systems at test pressures equal to or less than 1/2 psi (3.5 kPa).

The boiler and its gas connection must be leak tested before placing the boiler in operation.

Provisions for vent, bleed and gas relief lines (when applicable).

Applications of the gravity factor converts the figures given in table 1 to capacities with another gas of different specific gravity. Such application is accomplished by multiplying the capacities given in table 1 by the multipliers shown in table 5.

To determine the size of each section of gas piping in a system within the range of table 4 proceed as follows:

- Determine the gas demand of each appliance to be attached to the piping system. When table 4 is to be used to select the piping size, calculate the gas demand in terms of cubic feet per hour for each piping system outlet. The gas demand for an appliance can be found by dividing its heat input rate by the gas's heating value.
- Obtain or determine the length of piping from the gas meter or service regulator to the appliance(s).
- In table 1, select the row showing the distance to the most remote outlet or the next longer distance if the table does not give the exact length. This is the only distance used in determining the size of any section of gas piping. If the gravity factor is to be applied, the values in the selected row of table 4 are multiplied by the appropriate multiplier from table 5.
- Total the gas demands of all appliances on the piping system. Enter table 4, on the left hand side, at the row equal to or just exceeding the distance to the most remote outlet. Select the pipe size in the row with a capacity equal to or just exceeding the total gas demand. This is the required main gas supply line size leading away from the gas meter or regulator. To determine the pipe size required for each branch outlet leading away from the main supply line, determine the gas demand for that outlet. Enter table 4 on the same row, and select the branch pipe size for a capacity equal to or just exceeding the demand at that outlet. The main line can be resized for a lesser capacity after each branch outlet, since the gas demand is reduced. Total the gas demands of all remaining appliances branching off downstream on the main gas line. Re-enter table 4 in the same row and select the appropriate pipe size with adequate capacity. Repeat the branch sizing and main line re-sizing for any remaining appliances in the system.

EXAMPLE

Job Condition:

Determining the required gas pipe size for a system composed of two A. O. Smith 720 boilers and two 960 boilers to be installed as a multiple group, 50 lineal feet from meter. Gas to be used has a .60 specific gravity and heating value of 1,000 Btu per cubic foot.

Solution:

Two 720 Boilers	=	1,440,000 Btuh	(422 kw)
Two 960 Boilers	=	1,920,000 Btuh	(562 kw)
<u>Total Btuh Input</u>	=	<u>3,360,000 Btuh</u>	= (984 kw)

<u>Total Btuh Input</u>	=	<u>3,360,000 Btuh</u>	= 3,360 cf/h
<u>Btu per Cubic Foot of Gas</u>		<u>1,000</u>	

With a cubic foot per hour demand of 3,360 and with 50 lineal feet of gas supply line, table 4 shows a pipe size of 3" is required.

NOTE: For other than .60 specific gravity, apply multiplier factor as shown in table 5.

HIGH ALTITUDE INSTALLATIONS

IN CANADA

Acceptance of these models for use at altitudes above 2000 feet (610 m) is based on field test of the individual installation by the provincial/state authority having jurisdiction.

IN THE U.S.A.



WARNING

INSTALLATIONS ABOVE 2000 FEET REQUIRE REPLACEMENT OF THE BURNER ORIFICES IN ACCORDANCE WITH SECTION 8.1.2 OF THE NATIONAL FUEL GAS CODE (ANSI Z223.1). FAILURE TO REPLACE THE ORIFICES WILL RESULT IN IMPROPER AND INEFFICIENT OPERATION OF THE APPLIANCE RESULTING IN THE PRODUCTION OF INCREASED LEVELS OF CARBON MONOXIDE GAS IN EXCESS OF SAFE LIMITS WHICH COULD RESULT IN SERIOUS PERSONAL INJURY OR DEATH.

You should contact your gas supplier for any specific changes which may be required in your area.

Ratings specified by manufacturers for most boilers apply for elevations up to 2000 feet (610 m). For elevations above 2000 feet (610 m) ratings must be reduced by a rate of 4% for each 1000 feet (305 m) above sea level.

Example: A Dura-Max is rated at 720,000 Btu/hr. (211 kw) input at sea level. To operate the boiler at 5000 feet (1524 m) it must be derated by 20% (4% x 5) to a new rating of 576,000 Btu/hr. (169 kw) input.

The input reduction is primarily achieved by reducing the size of the main burner orifices. To do this, the main burner orifices require replacement with orifices sized for the particular installation elevation. When ordering, be sure to state the model number and the altitude of the location where the boiler is being installed.

Upon field deration of the boiler, adjustment to the gas pressure regulator is required. See CHECKING AND ADJUSTING THE INPUT in this manual for inlet and manifold pressure requirements.

Also, due to the input rating reduction required at high altitudes, the output rating of the appliance is also reduced and should be compensated for in the sizing of the equipment for applications.

WIRING CONNECTIONS

1. CONVENTIONAL INSTALLATIONS

All electrical work must be electrically bonded to ground in accordance with the requirements of the authority having jurisdiction or, in the absence of such requirements, with the National Electrical Code, ANSI/NFPA 70 and/or the Canadian Electrical Code Part 1, CSA C22.1, Electrical Code.

The electrical connections must be made so that the circulator will operate before the gas valve opens. At no time may the controlling system allow the burner to fire when there is no water flow through the boilers.

AN ELECTRICAL GROUND IS REQUIRED TO REDUCE RISK OF ELECTRIC SHOCK OR POSSIBLE ELECTROCUTION. Make the ground connection to the screw provided in the electrical supply junction box on the boiler.

IF ANY OF THE ORIGINAL WIRE, AS SUPPLIED WITH THE APPLIANCE, MUST BE REPLACED, IT MUST BE REPLACED WITH TYPE 105°C WIRE OR ITS EQUIVALENT, EXCEPT FOR THE FLAME SENSOR AND IGNITION CABLE WHICH ARE 250°C.

SERVICING WIRING AND/OR CONTROL



Label all wires prior to disconnection when servicing controls. Wiring errors can cause improper and dangerous operation.

Verify proper operation after servicing.

SYSTEMS EQUIPMENT INSTALLATION

The following is a brief description of the equipment required for installations noted in this manual. All installations must comply with local codes.

The boilers described in this manual may be used for space heating or for the heating of potable water. If the heater is to be used for hydronic space heating, follow the descriptions given for equipment

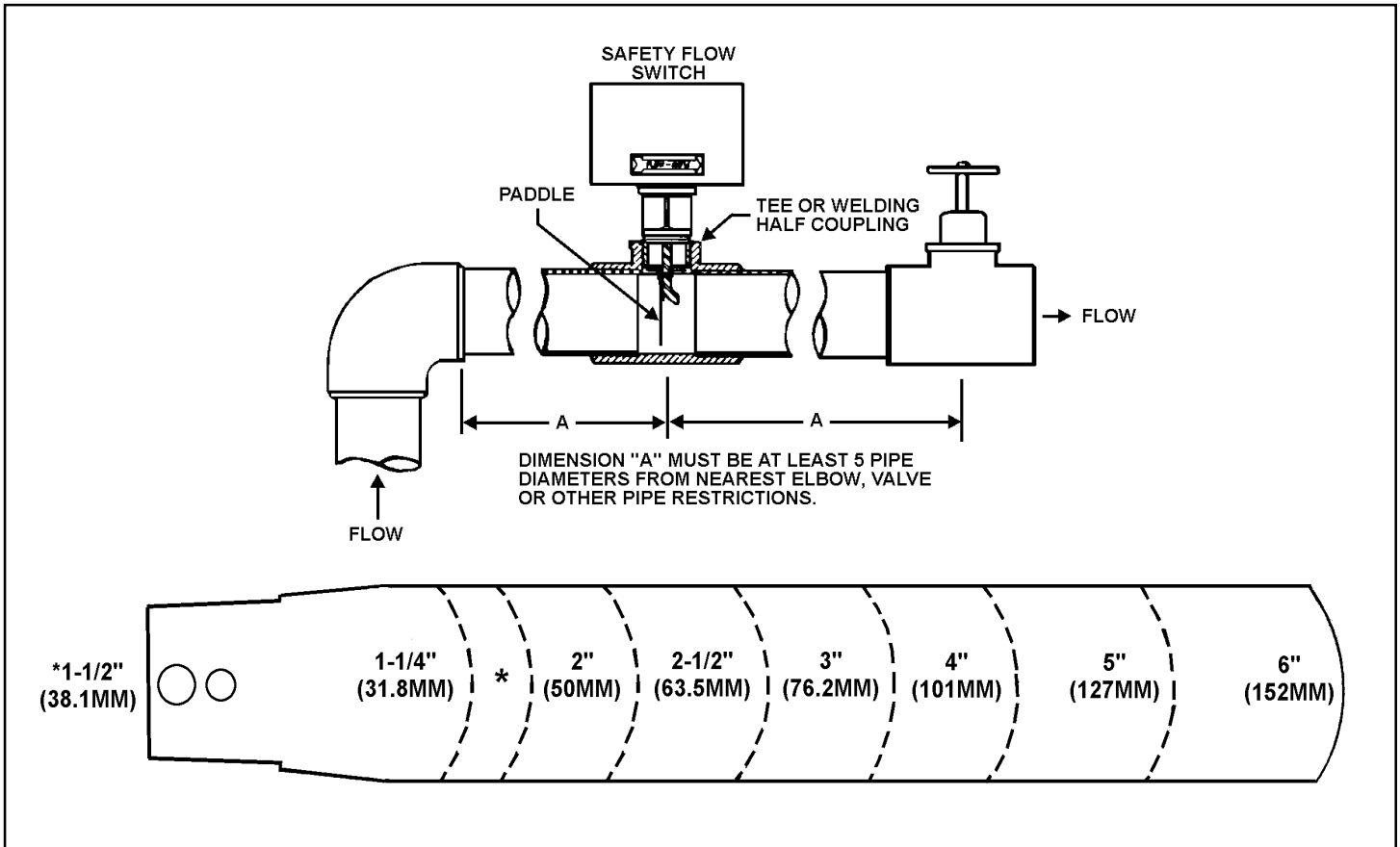

FIGURE 8

The flow switch shall be mounted in the top opening of the reducing tee and provide adequate paddle length in the flow stream. For example in a 2" pipe installation use a 2" x 2" x 1" reducing tee. For 2" or 3" pipe use the paddle segments as supplied. For other pipe sizes (i.e. 2-1/2") trim the paddle to the proper pipe size, see fig. 8. If a standard tee is used, install a face or hex bushing in the top opening. The paddle must be adjusted or trimmed to the size of the pipe in which it will be installed.

CAUTION

The paddle must not touch any part of the tee into which it is installed. Screw the flow switch in position so the flat of the paddle is at right angles to the flow. The arrow on the side case must point in the direction of the flow.

To adjust the flow rate setting:

1. Remove the flow switch cover.
2. For higher flow rate—turn the range adjusting screw clockwise.
3. For lower flow rate—turn the range adjusting screw counterclockwise.

Where units are installed in multiples, each boiler must be individually protected by a safety flow switch.

CIRCULATING PUMP

Dura-Max boilers are designed to operate over a wide range of temperatures and flow rates.

THE CIRCULATING PUMP MUST BE PROPERLY SIZED FOR YOUR APPLICATION.

Water hardness, system pressure drop and temperature rise across the boiler all affect how large a circulating pump must be.

Running "hard water" too slowly through the boiler can result in damage due to lime or scale accumulation.

Running "soft water" too quickly through the boiler can result in damage due to velocity flow erosion.

Table 4 has been designed to assist in determining operating ranges. Use this chart as a guide when sizing pumps.

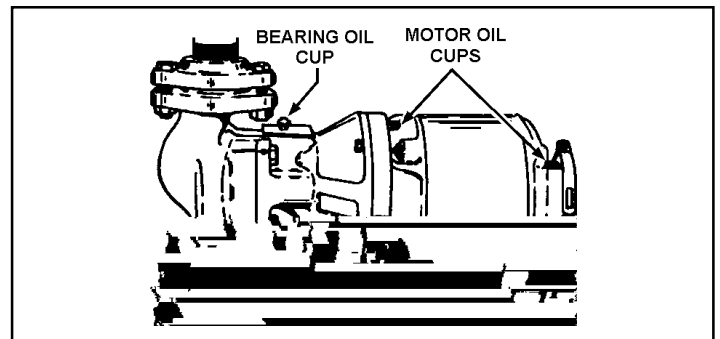

FIGURE 9

Although each circulator that requires oil is oiled and operated by the manufacturer, IT MUST BE OILED AGAIN BEFORE BEING OPERATED. Oil the three oil cups (2 on the motor, 1 on the pump) as instructed on the oil tube supplied with the unit, fig. 9.

Thereafter, during the heating season, lubricate the three oil cups
Theredrops in hreemotor ups

A system bypass should be installed as shown in fig. 10 to prevent boiler circulation starvation when the system zones call for reduced flow.

This bypass may also be used with multiple boilers manifolded for reverse-return flow. The system bypass would be installed from boiler outlet to suction side of pump.

Standard Dura-Max models are factory equipped for Single Stage Firing only.

Dura-Max models may be factory equipped for Dual Stage Firing. The gas valve automatically steps gas input down from full input to approximately 50% total input. System conditions will then

determine if boiler will shut down or if unit will return smoothly to full input.

Dura-Max models may also be equipped with modulation which automatically adjusts the boiler output to match the system heat loss and variations of system water flow. Minimum firing rate is 50%.

INSTALLATION AS BOILER REPLACEMENT

Installation as boiler replacement on an old system with large water volume may result in condensation within the boiler on cold starts. This condensing of water vapor in the combustion area can be prevented if a portion of the system water flow is diverted past the boiler to cause an increase in boiler temperature rise.

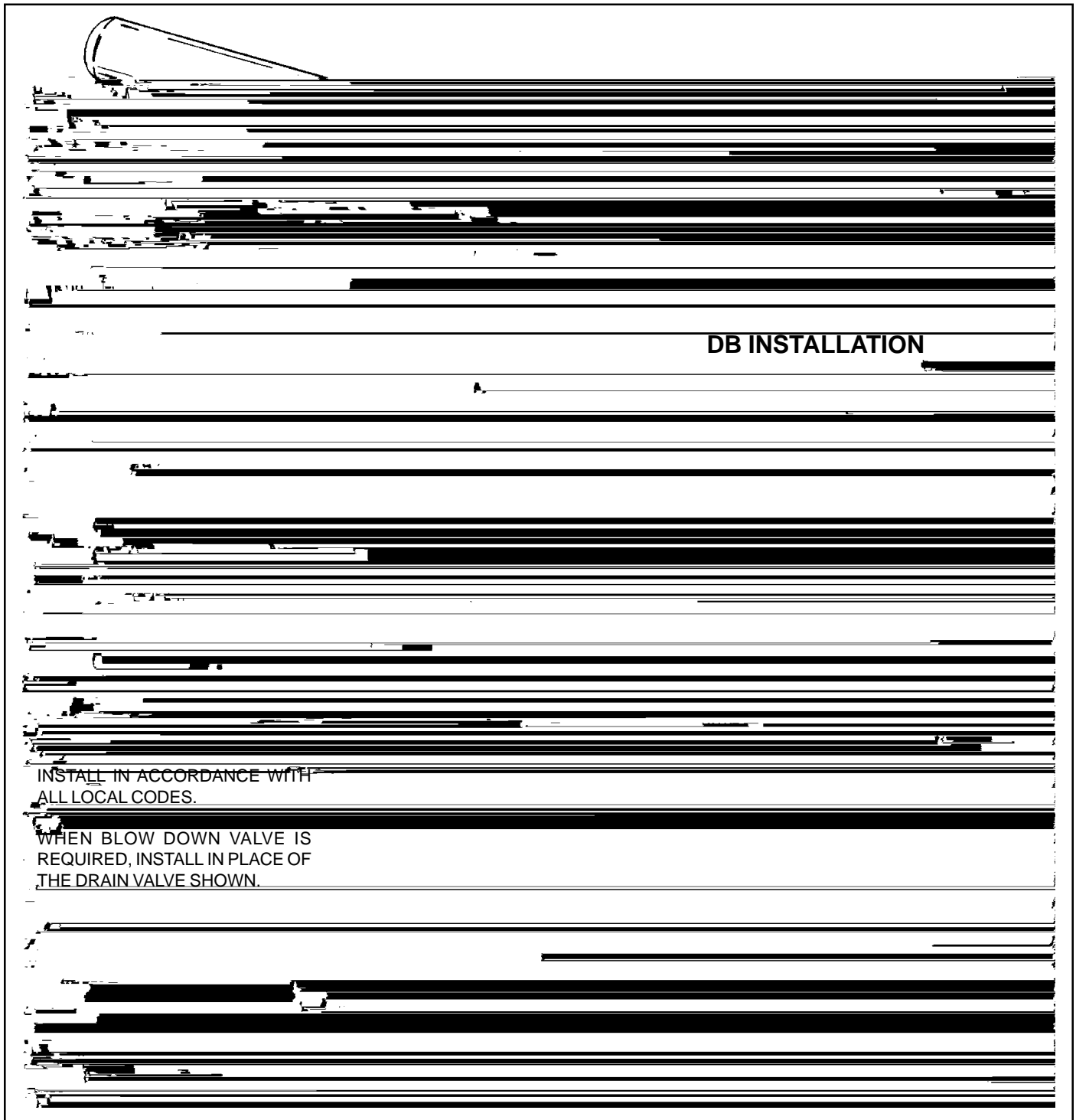
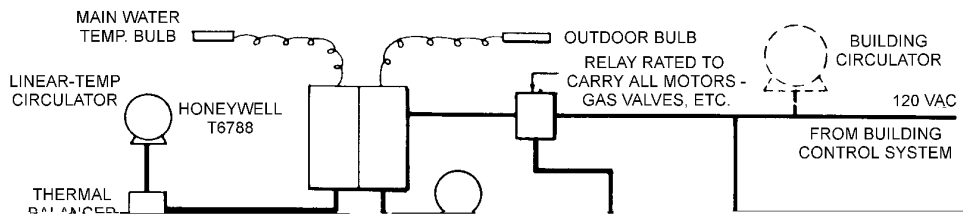

FIGURE 10



1. BUILDING TEMPERATURE CONTROLS SUPPLY ELECTRIC POWER TO BUILDING CIRCULATOR.
2. MAIN FLOW SWITCH PROVES MAIN WATER FLOW BEFORE ENERGIZING, SEQUENCING AND RESETTING CONTROLS.
3. OUTDOOR THERMOSTAT REQUIRED IF BUILDING CONTROLS DO NOT PROVIDE AUTOMATIC SHUT-DOWN OF RESET CONTROLS DURING WARM WEATHER.

BYPASS BALANCING

With systems where water temperature can be expected to drop appreciably due to long standby periods, or heavy draw down, a bypass pipe of at least 1" size with a balancing cock should be installed between the boiler inlet and outlet (see fig. 10). When the system first starts, the valve should be slowly opened until the condensing ceases. This adjustment remains at a permanent setting to establish required temperature rise across the boiler.

LINEAR-TEMP SPACE HEATING APPLICATIONS

Controlling of these systems is decided mainly by the type of building system controlling that is desired. A single boiler installation might be controlled directly from space temperature thermostat(s). Multiple boiler installations are more effective when the boilers are sequenced in and out of operation by some form of main water temperature controller. With one or two boilers, individual control set at progressive temperature may be used. For more than two boilers, electronic sequencing controlling is recommended.

Individual controls, or the separate stages of a step controller, should fire a boiler and also start the boiler loop circulator whenever that boiler is fired. Some large installations may require the firing of more than one boiler per stage.

The system or primary circulator may or may not be controlled by the boiler sequencer. When this pump is operated through the first switch of any type of step controller, care should be taken to determine if a motor starter is needed due to insufficient switch capacity.

If the primary pump is controlled by a manual switch or any other controllers, the electric current supply to the boiler group should be through the primary pump controller. The fast response of A.O. Smith boilers eliminates any need to maintain boiler temperature when the system is satisfied. Wiring should always prevent firing of boiler(s) when there is no water flow in the mains.

Installation diagrams show safety flow switches in the outlet piping from each boiler as good protection against any boiler being fired when the boiler loop circulator is not in operation.

These safety flow switches will also provide some protection if there is a loss of water.

LINEAR-TEMP multiple boiler installations are especially adapted to the use of outdoor reset for main water temperatures. This feature is not mandatory but offers smooth, efficient operation of a modern system.

Outdoor reset systems should utilize an automatic shutdown control if there is a continuous recirculating main and/or if the entire building is not under control of space temperature thermostats. A single bulb outdoor sensing control will serve this requirement. This precaution will prevent overheating of halls, stairways or other uncontrolled areas. There are occasions when outdoor temperatures are temporarily too warm for even a moderate amount of heating in these areas.

Space temperature controlling can be varied to meet the building requirements. Either the single thermostat, as shown, or multiple zone thermostats should control a common relay. This relay controls electric power to the system primary circulator and to the main water temperature controller. This provides for water movement in the system before the main temperature controller can start the secondary circulating pump or fire the boiler.

Figure 11 shows a typical field wiring diagram for a single stage boiler LINEAR-TEMP installation. The boiler may be controlled by a main temperature controller as shown or may include outdoor reset if desired.

The following fig's. 11 thru 13 are shown as layouts for various choices of controls often found in commercial heating. These layouts are not intended to be wiring diagrams and only show the relation of one device to another in the system.

Figure 11 is a typical layout of controls for two boilers with two circulators and thermal balancers plus optional outdoor reset control.

Figure 12 is shown as a typical control group for various multiple boiler installations, and is not intended to imply that this is the only arrangement to be considered. Commercial size installations are always best when designed to individual building requirements.

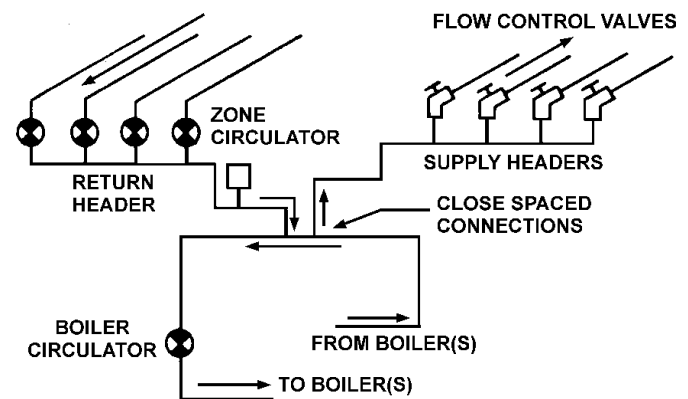

FIGURE 13

LINEAR-TEMP SPACE HEATING INSTALLATIONS

A. New Installation

The A.O. Smith LINEAR-TEMP system has been designed to provide efficient, trouble-free operation of these boilers with any of the following conditions:

- unknown system flow rate.
- varying flow rates as with zoned systems and 3-way valve system.
- multiple boiler installations.

Figure 14 shows piping and accessory arrangement for 14ith4(.3)A for 1

generator type boilers establish temperature rises. The deciding factor in choice of boiler temperature rise relates to the boiler inlet temperature. Boiler outlet, minus system temperature drop, is boiler inlet temperature. THE BOILER TEMPERATURE RISE SHOULD NOT RAISE THE OUTLET TEMPERATURE UP TO THE MAXIMUM 250°F (115°C) SETTING OF THE LIMIT CONTROL.

If inlet temperature (plus temperature rise) of any boiler on the group exceeds 240°F (115°C), that boiler and all downstream boilers will shut down (cycle on and off).

B. Commercial Boiler Replacements

Application of LINEAR-TEMP to a commercial boiler replacement with an old multiple pump installation is an excellent way to modernize the system. The A. O. Smith boiler(s) should be installed on a pipe loop with a separate circulating pump. Use table 7 to determine pipe sizes and operating ranges.

The following illustration shows how the system headers should be connected to pipe loop that is installed with the replacement

boiler(s). Make-up water connections, and accessories are not shown.

Supply and return headers of the old system should be connected to the boiler loop with a pair of tees set close together. The boiler loop pump and the boiler(s) should be wired to operate only when any of the system pumps are in operation. The number of zone pumps that may be in operation at any particular time will take their required flow rate out from the first tee in the boiler piping. This water will be circulated through the proper branches from the supply header to the zones calling for heat. The water will be brought back to the return header and then into the second tee in the boiler pipe loop. There will be no conflict between the boiler pump and the zone pumps when the two tees in the boiler loop are placed close together.

Normal use of flow control valves is required to prevent cross circulation of zones as with any multiple pump system.

Large systems with multiple boilers should include main water temperature controls (with or without outdoor reset) to sequence the boiler on and off, in relation to the load on the system.

TABLE 7, DuraMax Pump Performance Requirements

Model	Water Category	Temp Rise		Flow Rate		HdLoss*		Pipe Size Sched. 40	Taco Circulator Models
		F	C	GPM	LPM	ft	M		
DW-720	Soft	35	19.4	17	3.7	1.1	2"	#0012 (1/7 HP)	
	Normal	25	13.9	18	6.2	1.9	2"	#120 (1/6 HP)	
	Hard	18	10.0	18	12.6	3.8	2"	#1935 (1/3 HP)	
	Hard	18	10.0	18	7.4	2.3	2 1/2"	#121 (1/4 HP)	
DW-840	Soft	35	19.4	17	3.7	1.1	2"	#0012 (1/7 HP)	
	Normal	25	13.9	18	6.2	1.9	2"	#120 (1/6 HP)	
	Hard	18	10.0	18	12.6	3.8	2"	#1935 (1/3 HP)	
	Hard	18	10.0	18	7.4	2.3	2 1/2"	#121 (1/4 HP)	
DW-960	Soft	35	19.4	17	3.7	1.1	2"	#0012 (1/7 HP)	
	Normal	25	13.9	18	6.2	1.9	2"	#120 (1/6 HP)	
	Normal	25	13.9	18	6.2	1.9	2"	#120 (1/6 HP)	
	Hard	18	10.0	18	12.6	3.8	2"	#1935 (1/3 HP)	
DW-1080	Soft	35	19.4	17	3.7	1.1	2"	#0012 (1/7 HP)	
	Normal	25	13.9	18	6.2	1.9	2"	#120 (1/6 HP)	
	Normal	25	13.9	18	6.2	1.9	2"	#120 (1/6 HP)	
	Hard	19	10.0	18	12.6	3.8	2"	#1935 (1/3 HP)	
DW-1210	Soft	35	19.4	17	3.7	1.1	2"	#0012 (1/7 HP)	
	Normal	25	13.9	18	6.2	1.9	2"	#120 (1/6 HP)	
	Normal	25	13.9	18	6.2	1.9	2"	#120 (1/6 HP)	
	Hard	19	10.0	18	12.6	3.8	2"	#1935 (1/3 HP)	
DW-1350	Soft	35	19.4	17	3.7	1.1	2"	#0012 (1/7 HP)	
	Normal	25	13.9	18	6.2	1.9	2"	#120 (1/6 HP)	
	Normal	25	13.9	18	6.2	1.9	2"	#120 (1/6 HP)	
	Hard	18	10.0	18	12.6	3.8	2"	#1935 (1/3 HP)	
DW-1480	Soft	35	19.4	17	3.7	1.1	2"	#0012 (1/7 HP)	
	Normal	25	13.9	18	6.2	1.9	2"	#120 (1/6 HP)	
	Normal	25	13.9	18	6.2	1.9	2"	#120 (1/6 HP)	
	Hard	18	10.0	18	12.6	3.8	2"	#1935 (1/3 HP)	
DW-1610	Soft	35	19.4	17	3.7	1.1	2"	#0012 (1/7 HP)	
	Normal	25	13.9	18	6.2	1.9	2"	#120 (1/6 HP)	
	Normal	25	13.9	18	6.2	1.9	2"	#120 (1/6 HP)	
	Hard	20	11.0	18	12.6	3.8	2"	#1935 (1/3 HP)	
DW-1810	Soft	38	21.0	17	3.7	1.1	2"	#0012 (1/7 HP)	
	Normal	28	15.0	18	6.2	1.9	2"	#120 (1/6 HP)	
	Normal	28	15.0	18	6.2	1.9	2"	#120 (1/6 HP)	
	Hard	22	12.0	18	12.6	3.8	2"	#1935 (1/3 HP)	

* - Head loss includes the loss through

Pressure drop includes the loss through 40' (12 m) of pipe

- Water Category**
 Soft
 Normal
 Hard

Taco pumps shown. Equivalent Armstrong, Bell & Goss
 Always ensure adequate support for pump and piping.

TABLE 8.

NO.	SUGGESTED ITEMS FOR INSTALLATION
1.	SHORT PIPE NIPPLE AND PAIR OF BOILER LOOP TEES IN PIPING BETWEEN SYSTEM SUPPLY AND RETURN - ONE SET PER EACH BOILER
2.	BOILER PIPE LOOP (See Piping Sizing Data Table 3.)
3.	BOILER CIRCULATING PUMP (See Piping Sizing Data Table 3.)
4.	THERMOMETER
5.	PRESSURE GAUGE
6.	LOW WATER CUT-OFF (If Required By Local Code.)
7.	SAFETY FLOW SWITCH
8.	RELIEF VALVE (Furnished with Boiler)
9.	BOILER INLET - OUTLET
10.	SYSTEM SUPPLY TEMPERATURE THERMOMETER
11.	DRAIN OR BLOW-DOWN VALVE

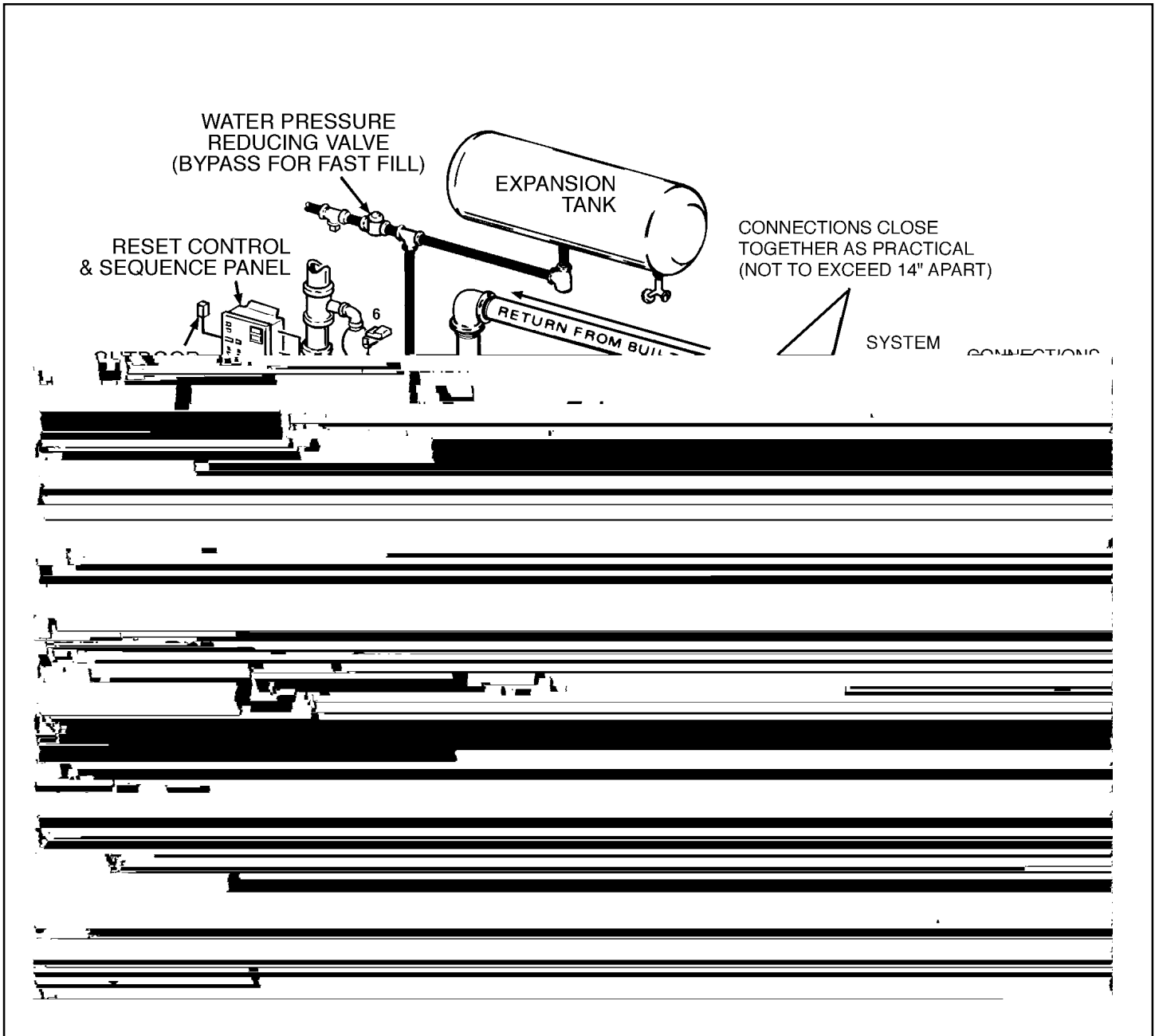
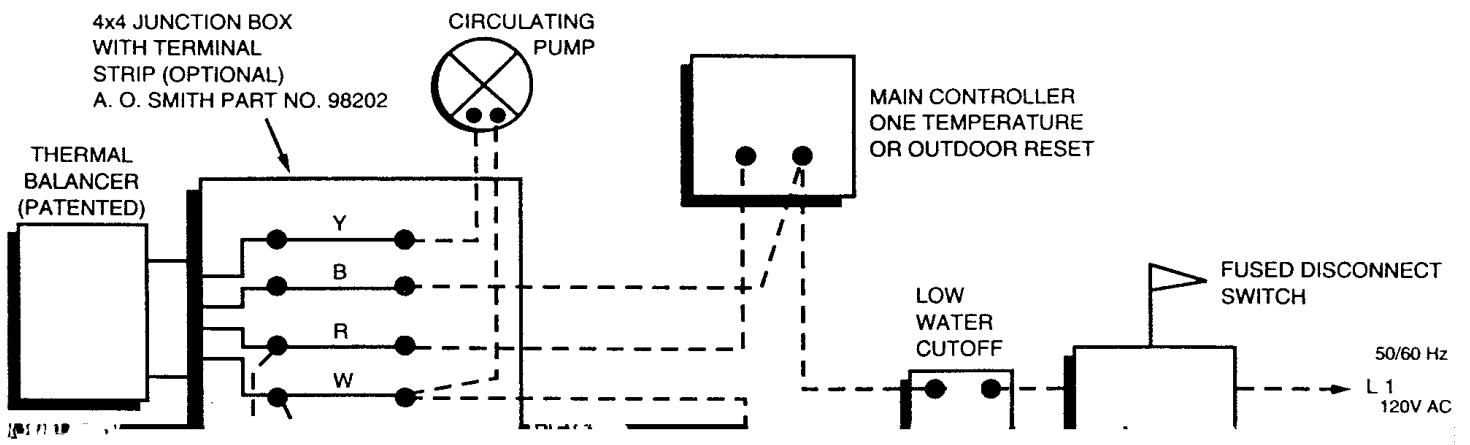
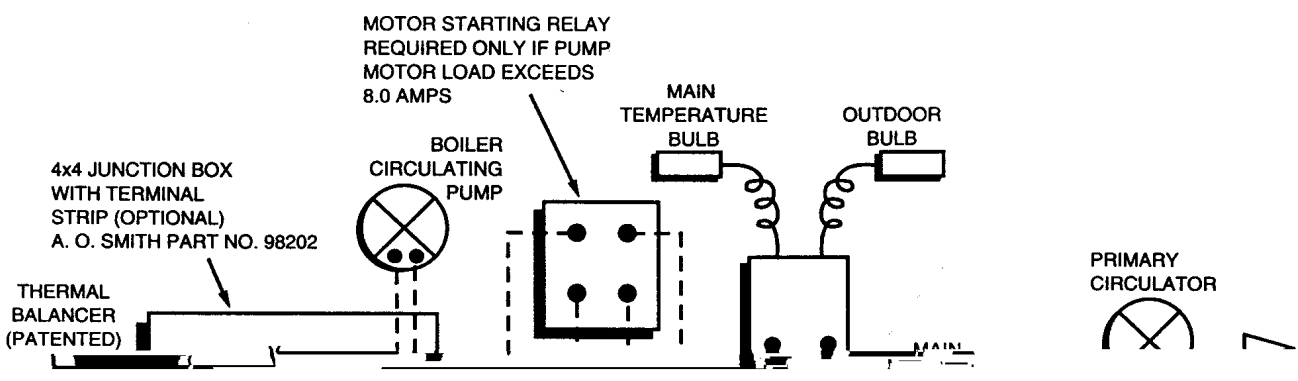

FIGURE 14



USE ONLY TYPE 105°C THERMOPLASTIC OR ITS EQUIVALENT
IF ANY OF THE ORIGINAL WIRES AS SUPPLIED MUST BE REPLACED.

BOILER CONVENTIONAL SYSTEM
FIGURE 15



USE ONLY TYPE 105°C THERMOPLASTIC OR ITS EQUIVALENT
IF ANY OF THE ORIGINAL WIRES AS SUPPLIED MUST BE REPLACED.

ONE BOILER LINEAR-TEMP SYSTEM
FIGURE 16

DURA-MAX - SINGLE STAGE FIRING - UNITED STATES MODELS WITH PUMP.

120 VOLT SYSTEM CONTROLLER

PUMP SIZE
PUMP BODY 1 1/2"

POWER VENT KIT (OPTIONAL)
200348-12 HS-4 1/3 HP
200348-13 HS-5 1 HP

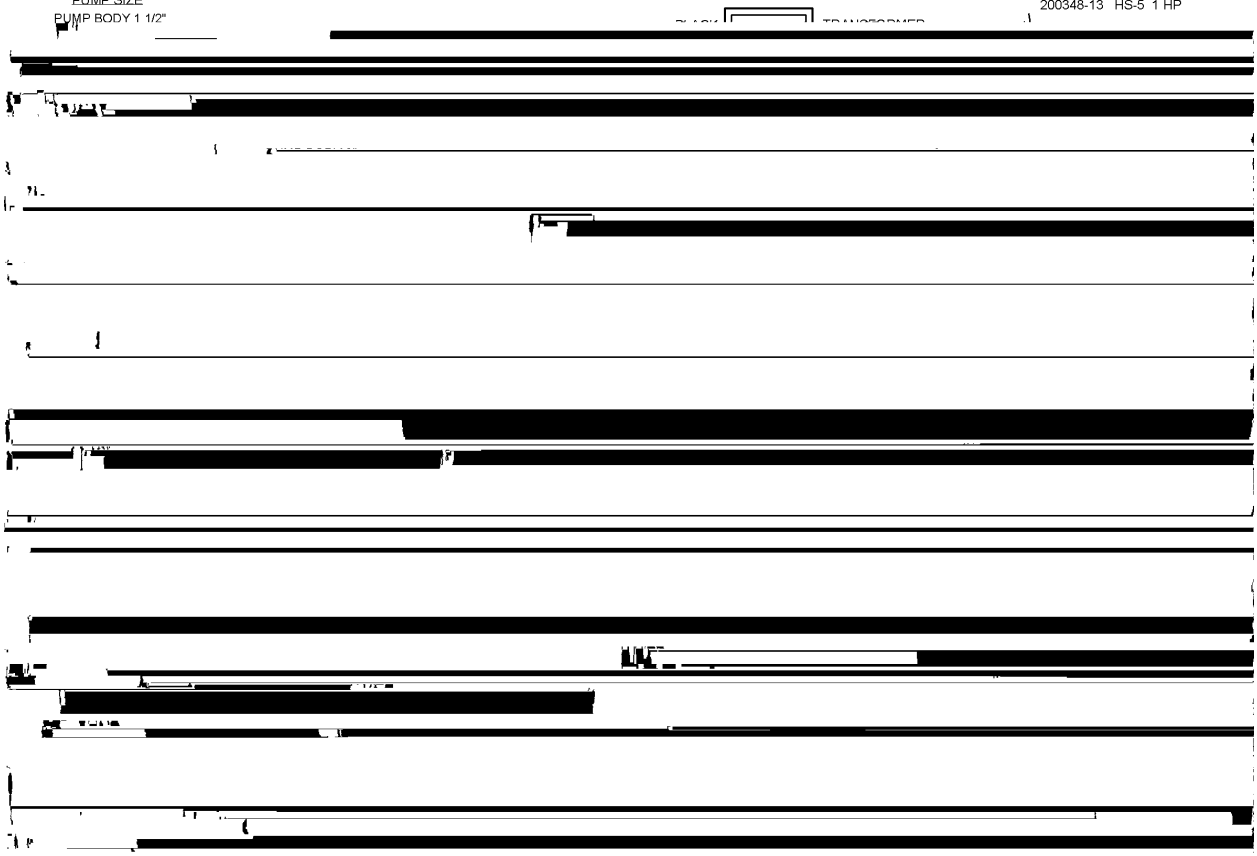

DURA-MAX - PUMP MOUNT - SINGLE STAGE - SCHEMATIC DIAGRAM

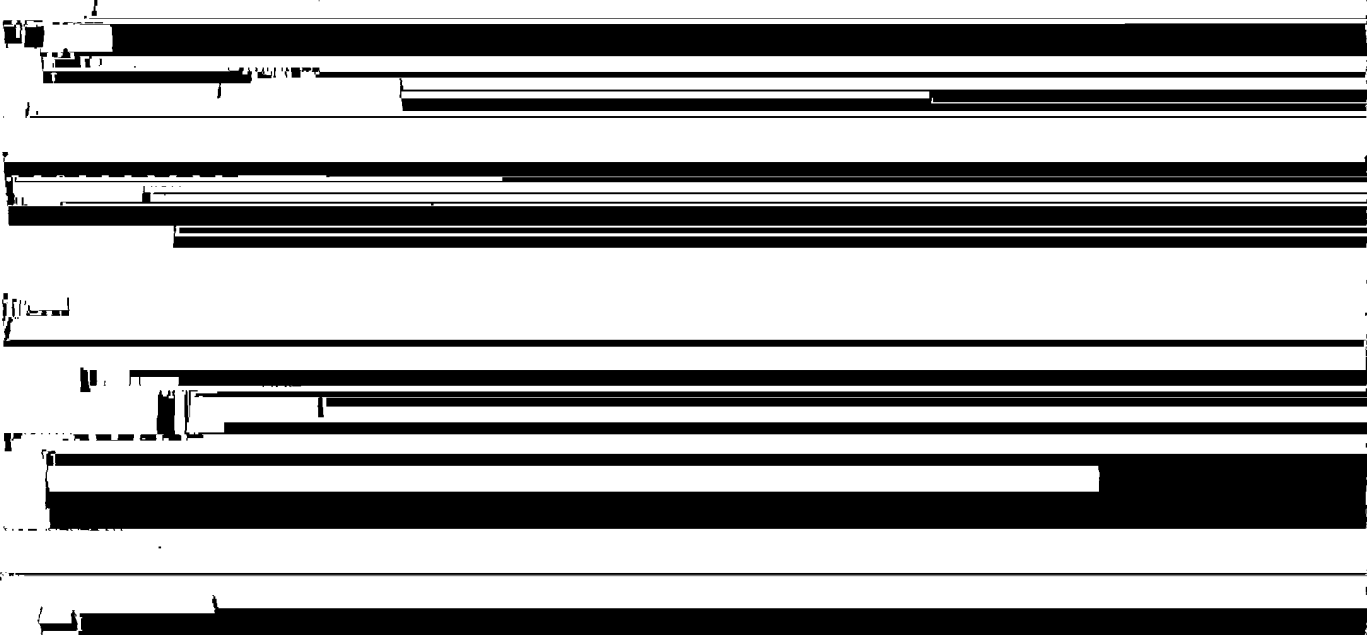
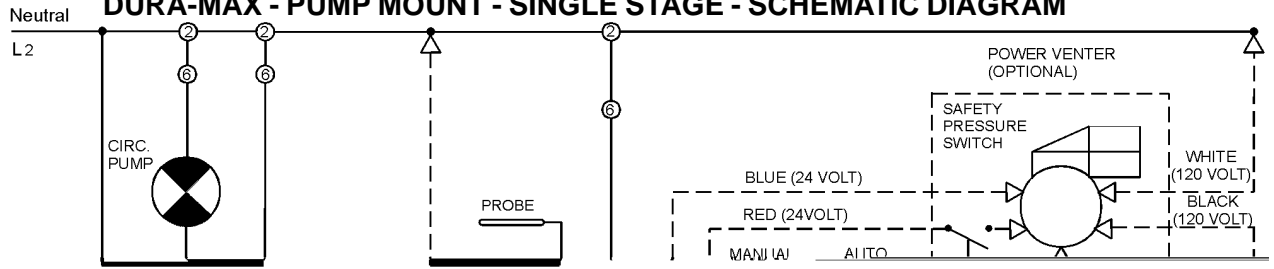

DURA-MAX - DUAL STAGE FIRING - UNITED STATES MODELS WITH PUMP.

120 VOLT SYSTEM CONTROLLER

PUMP SIZE
 PUMP BODY 1 1/2"
 PUMP BODY 2"
 PUMP BODY 2 1/2"

POWER VENT KIT (OPTIONAL)
 200348-12 HS-4 1/3 HP
 200348-13 HS-5 1 HP

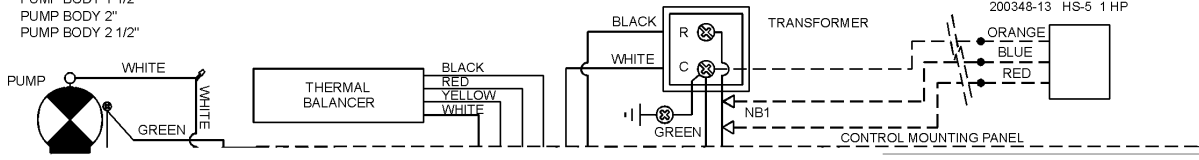

DURA-MAX - PUMP MOUNT - DUAL STAGE - SCHEMATIC DIAGRAM

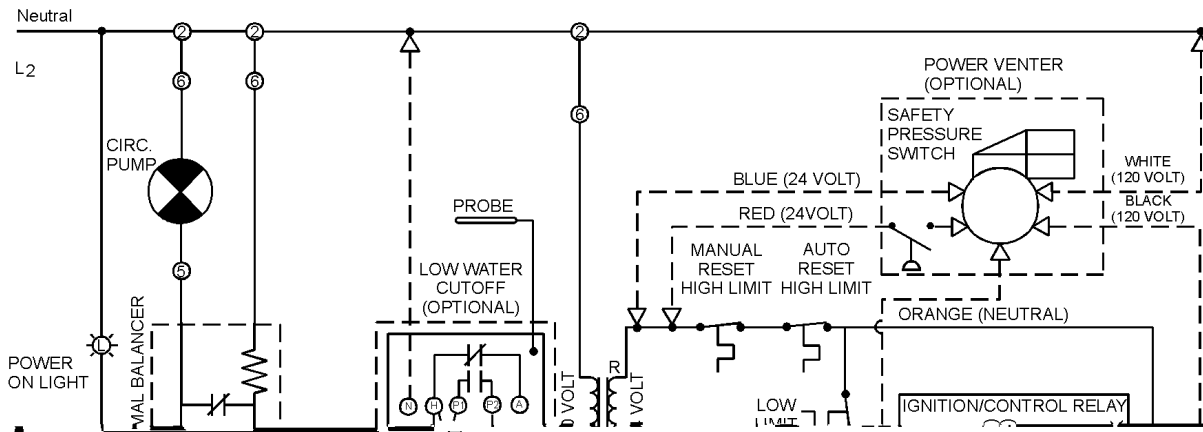

DUR [REDACTED] DELS
WITH PUMP - 120 VOLT SYSTEM CONTROLLER

DURA-MAX - PUMP MOUNTED - MODULATING - SCHEMATIC DIAGRAM

**DURA-MAX - SINGLE STAGE FIRING - UNITED STATES & CANADIAN MODELS
WITHOUT PUMP. 120 VOLT SYSTEM CONTROLLER**

DURA-MAX - SINGLE STAGE FIRING - SCHEMATIC DIAGRAM

DURA-MAX - DUAL STAGE FIRING - UNITED STATES & CANADIAN MODELS WITHOUT PUMP. 120 VOLT SYSTEM CONTROLLER

--- FIELD WIRED
 _____ FACTORY WIRED

TRANSFORMER

POWER VENT KIT (OPTIONAL)
 200348-12 HS-4 1/3HP CV
 200348-13 HS-5 1 HP CV

DURA-MAX - DUAL STAGE FIRING - SCHEMATIC DIAGRAM

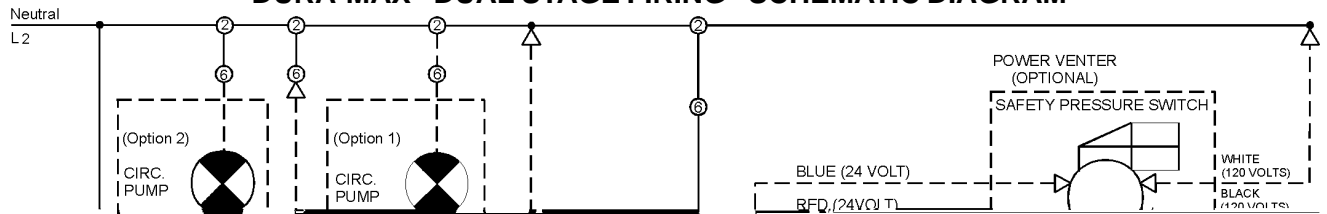

DURA-MAX - MODULATED FIRING - UNITED STATES & CANADIAN MODELS WITHOUT PUMP. 120 VOLT SYSTEM CONTROLLER

POWER VENT KIT (OPTIONAL)
200348-12 HS-4 1/8HP
200348-13 HS-5 1HP

WHITE (OPTIONAL)

GRAY

BLACK



DURA-MAX - MODULATED FIRING - SCHEMATIC DIAGRAM

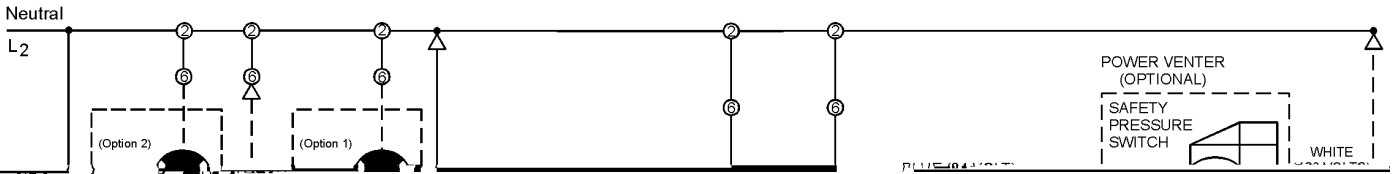

HOT WATER SUPPLY APPLICATIONS

Cer-Temp 80 Recovery Systems

WATER LINE CONNECTIONS

This section provides detailed installation diagrams for typical methods of application for the unit using a Cer-Temp 80 Recovery System (for one temperature water).

This equipment must be protected against loss of water or loss of water flow by the installation of a safety flow switch in the outlet piping from the boiler. Piping and wiring diagrams show the application of this accessory for this purpose.

These diagrams will serve to provide the installer with a reference for the materials and methods of piping necessary for installation. It is essential that all water and gas piping, vent connections, electrical wiring, and check and flow regulating valves be installed as shown on the diagrams.

Where excessive heat exchanger condensation exists due to continued low water inlet temperatures, a bypass balance loop must be installed (see page 15).

HARD WATER CONDITIONS

Where hard water conditions exist, water softening or the threshold type of water treatment is recommended. This will protect the dishwashers, coffee urns, water heaters, water piping and other equipment. When water softening or water treatment is not practical, a comparatively easy method of periodic lime removal from the unit must be employed.

WARNING

Lime accumulation can reduce the life of the equipment, reduce efficiency and waste fuel. Boiler failure due to lime or scale build-up voids the warranty.

These units are so constructed that lime removal is simple and complete, see PREVENTIVE MAINTENANCE.

ONE DURA-MAX (MODEL DW) COMMERCIAL BOILER WITH VERTICAL TANK

CAUTION

TO PREVENT CONDENSATION THE MINIMUM BOILER INLET TEMPERATURE IS 100°F (38°C)

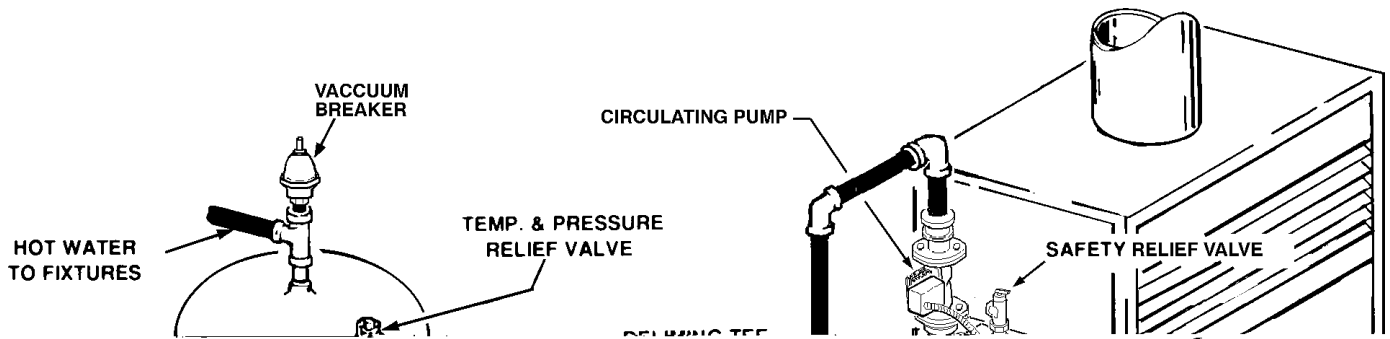

IMPORTANT

SAFETY FLOW SWITCH AS SHOWN TO PROTECT THE BOILER IN CASE OF WATER SERVICE INTERRUPTION OR CIRCULATOR FAILURE

SAFETY RELIEF VALVE RATING SHOULD NOT EXCEED PRESSURE CAPACITY OF ANY COMPONENT IN THE SYSTEM.

CAUTION

PUMP MUST BE RATED FOR SYSTEM OPERATING TEMPERATURES AND PRESSURE.

INSTALL IN ACCORDANCE WITH ALL LOCAL CODES.

SEE PAGE 31 FOR
ADDITIONAL PIPING INFORMATION.

SEE TABLE 7 FOR GUIDE TO PIPE AND PUMP SIZING.

+ BALL VALVES ARE SHOWN FOR SERVICING BOILER, HOWEVER, LOCAL CODES SHALL GOVERN THEIR USAGE.

ONE DURA-MAX (MODEL DW) COMMERCIAL BOILER WITH HORIZONTAL TANK



TO PREVENT CONDENSATION THE MINIMUM BOILER INLET TEMPERATURE IS 100°F (38°C)

IMPORTANT

SAFETY FLOW SWITCH AS SHOWN TO PROTECT THE BOILER IN CASE OF WATER SERVICE INTERRUPTION OR CIRCULATOR FAILURE.

INSTALL IN ACCORDANCE WITH ALL LOCAL CODES.

SEE PAGE 31 FOR
ADDITIONAL PIPING INFORMATION.



PUMP MUST BE RATED FOR SYSTEM OPERATING TEMPERATURES AND PRESSURE.

SEE TABLE 7 FOR GUIDE TO PIPE AND PUMP SIZING.

- * SAFETY RELIEF VALVE RATING SHOULD NOT EXCEED PRESSURE CAPACITY OF ANY COMPONENT IN THE SYSTEM.
- + BALL VALVES ARE SHOWN FOR SERVICING BOILER, HOWEVER, LOCAL CODES SHALL GOVERN THEIR USAGE.

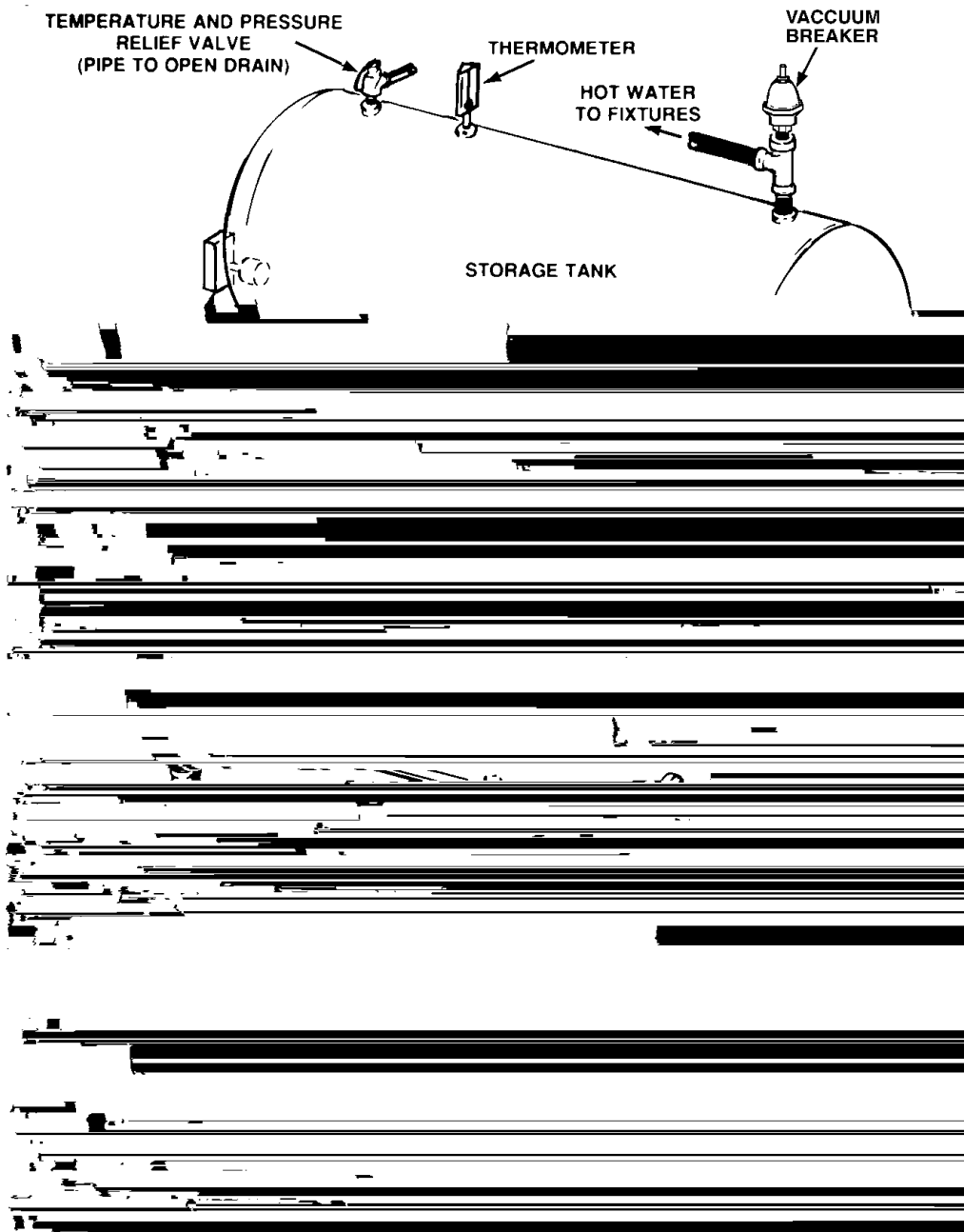

FIGURE 21

TWO DURA-MAX (MODEL DW) HOT WATER SUPPLY BOILERS WITH VERTICAL TANK



CAUTION

TO PREVENT CONDENSATION THE MINIMUM BOILER INLET TEMPERATURE IS 100°F (38°C)

SEE PAGE 31 FOR ADDITIONAL
PIPING INFORMATION.



CAUTION

PUMP MUST BE RATED FOR SYSTEM OPERATING
TEMPERATURE AND PRESSURE.

PRESSURCP

TWO DURA-MAX (MODEL DW) HOT WATER SUPPLY BOILERS WITH HORIZONTAL TANK



TO PREVENT CONDENSATION THE MINIMUM BOILER INLET TEMPERATURE IS 100°F (38°C)

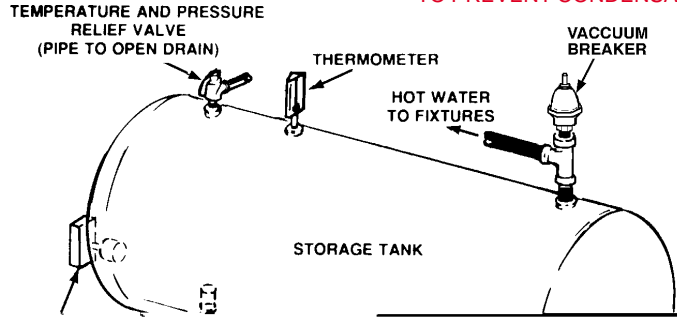

SEE PAGE 31 FOR ADDITIONAL PIPING INFORMATION.

IMPORTANT

THE INSTALLATION OF SAFETY FLOW SWITCHES AS SHOWN IS REQUIRED TO PROTECT THE BOILER IN CASE OF WATER SERVICE INTERRUPTION OR CIRCULATOR FAILURE.

NOTE: THERMOMETERS, RELIEF VALVES, CIRCULATORS, SAFETY FLOW SWITCHES AND TANK CONTROLS ARE AVAILABLE THROUGH A.O.SMITH.



PUMP MUST BE RATED FOR SYSTEM OPERATING TEMPERATURE AND PRESSURE.

- * SAFETY RELIEF VALVE RATING SHOULD NOT EXCEED PRESSURE CAPACITY OF ANY COMPONENT IN THE SYSTEM.

INSTALL IN ACCORDANCE WITH ALL LOCAL CODES.

- + BALL VALVES ARE SHOWN FOR SERVICING BOILER, HOWEVER, LOCAL CODES SHALL GOVERN THEIR USAGE.

ALL PIPING MUST BE SUPPORTED.

Guide To Pipe and Pump Sizing Two (2) Boiler Systems

Model	Common Manifold Pipe Size "A" (Min.)	Boiler Pipe Size "B" (Min.) and Pump
720, 840	2-1/2" NPT	See Table 7
960-1810	3" NPT	

Pipe and pump capacities for two (2) boiler systems based on 100 equivalent feet (30 meters) heater to tank loop.

FIGURE 23

WITH TWO VERTICAL TANKS

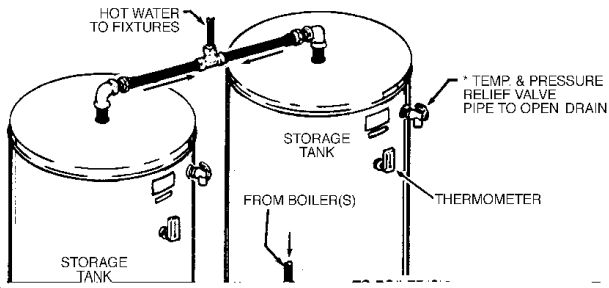

WITH THREE VERTICAL TANKS

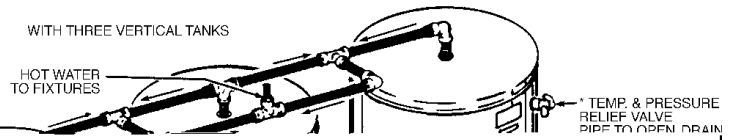

**MIXING VALVE APPLICATION
 FOR TWO TEMPERATURE WATER**

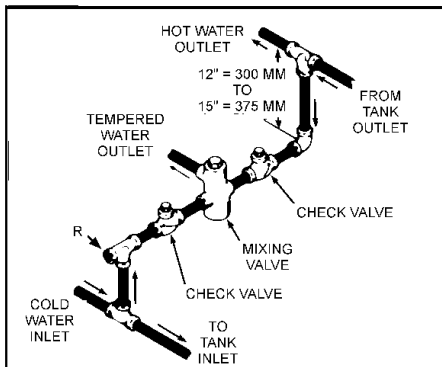

CIRCULATING RETURN LINE CONNECTIONS

- TEMPERED WATER LOOP, IF USED, CONNECT TO POINT R
- STORAGE TEMPERATURE WATER LOOP, IF USED, CONNECT TO ANY OPENING NEAR BOTTOM OF TANK.

**MODIFIED VERSION USING
 OTHER THAN A.O. SMITH STORAGE TANK**

ASSUMES 50 EQUIVALENT FEET OF PIPING OR LESS.

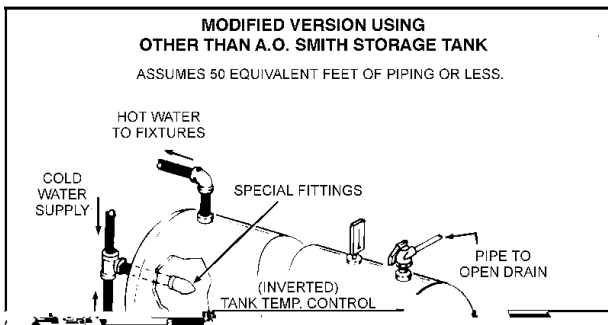

TWO HORIZONTAL TANK INSTALLATION

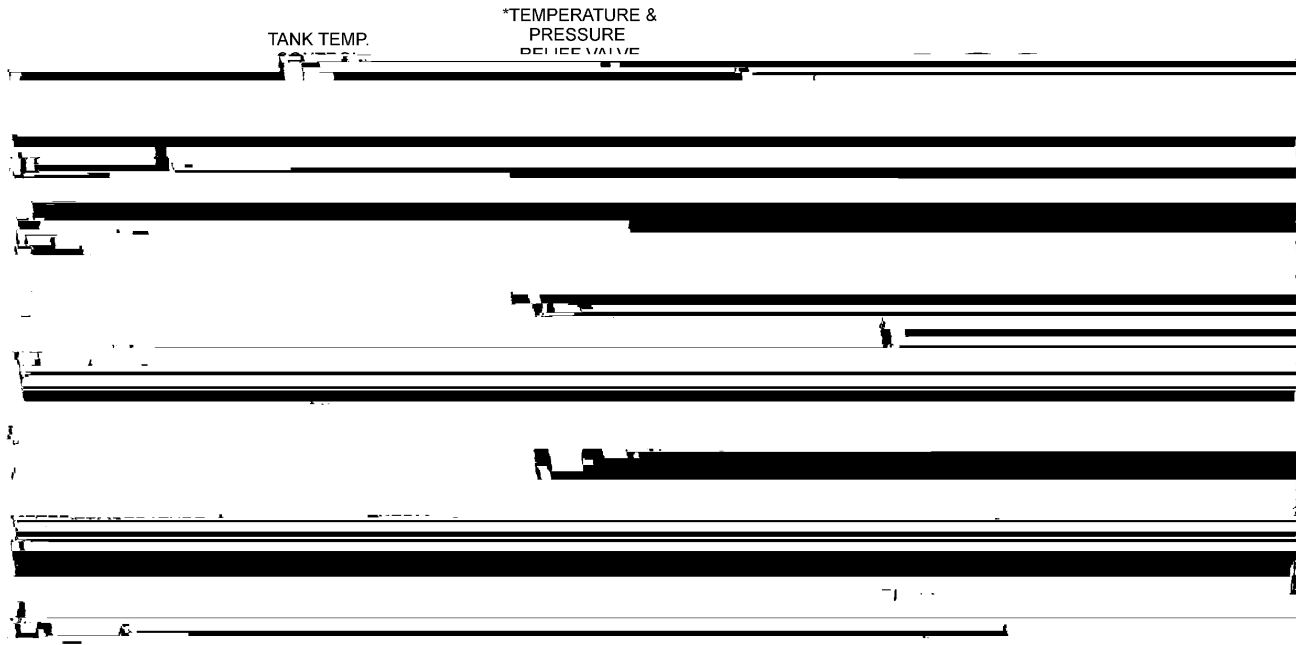

THREE HORIZONTAL TANK INSTALLATION

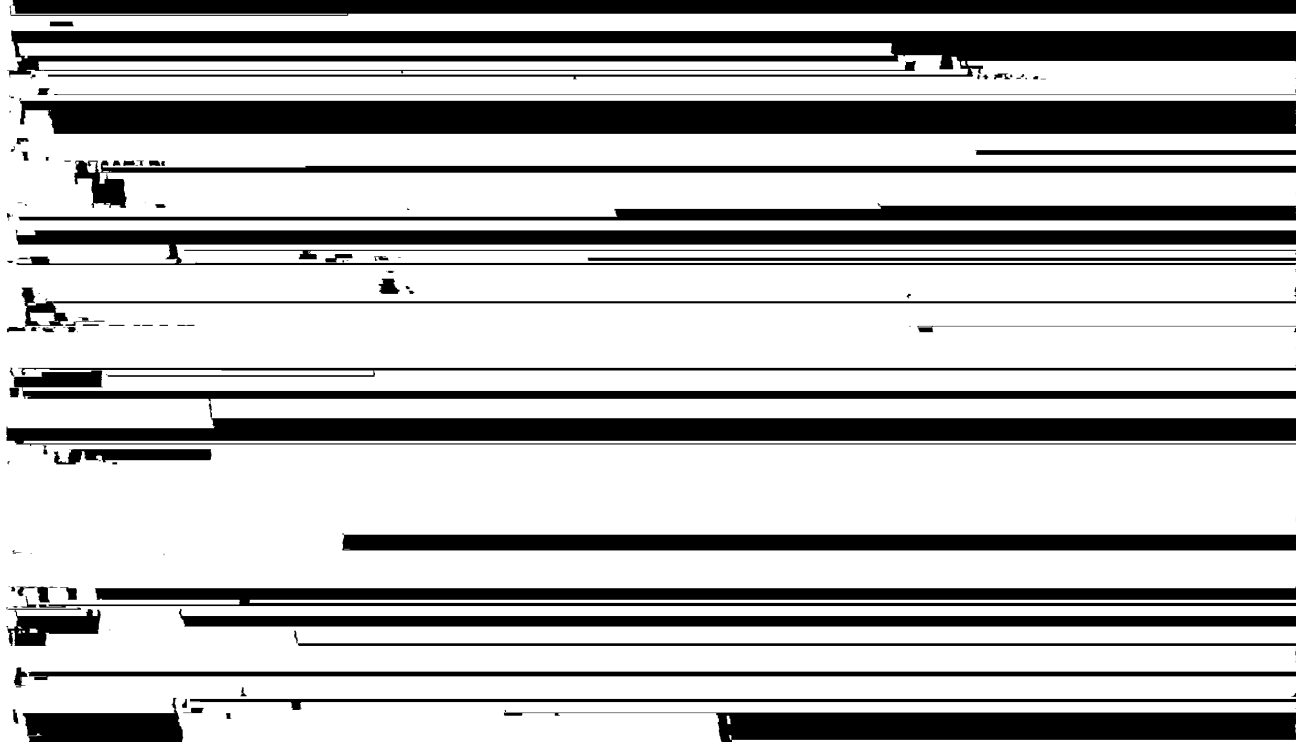

FIGURE 25

START-UP AND OPERATING INSTRUCTIONS

WARNING

After placing boiler into operation, the ignition system safety shutoff device must be tested by the following test method.

1. Reset Manual High Temperature Safety Limit Control (High Limit) to the lowest setting. (See figures 3 or 4, pages 5 or 6).

2. Reset System Controller to maximum setting, causing a call for heat and allowing unit to run until High Limit trips.
3. Reset Manual High Temperature Safety Limit Control to original temperature setting.
4. Push the reset button, unit should run.
5. Reset system controller to desired temperature.

If unit fails to run, see "TROUBLESHOOTING" section in this manual.

These units are so constructed that lime removal is simple and complete, see PREVENTIVE MAINTENANCE.

INTERNAL CONTAMINANTS

The system must be internally cleaned and flushed after a new or replacement unit has been installed to remove contaminants that may have accumulated during installation. This is doubly important when a replacement unit is installed into an existing system where Stop Leak or other boiler additives have been used.

All systems should be completely flushed with a grease removing solution to assure trouble-free operation. Pipe joint compounds, soldering paste, grease on tubing and pipe all tend to contaminate a system.

Failure to clean and flush the system can cause solids to form on the inside of the heat exchanger, can produce acid concentrations that become corrosive, can allow excessive amounts of air or other gases to form which could block circulation, foul system accessories and damage circulator seals and impellers.

It is recommended that after installation, the boiler and system when filled should include the proper percentage of cleaning solution related to approximate water volume of the system. Fire and circulate for about one hour and then flush clean with fresh water. Commercial grease removing solutions are available.

PRECAUTIONS

If the unit is exposed to the following, do not operate boiler until all corrective steps have been made by a qualified serviceman:

1. Exposure to fire.
2. If damaged.
3. Firing without water.
4. Sooting.

If the heater has been exposed to flooding it must be replaced.

IMPORTANT

ONLY QUALIFIED PERSONNEL SHALL PERFORM THE INITIAL FIRING OF THE HEATER. AT THIS TIME THE USER SHOULD NOT HESITATE TO ASK THE INSTALLER ANY QUESTIONS REGARDING THE OPERATION AND MAINTENANCE OF THE UNIT.

CHECKING AND ADJUSTING THE INPUT

NOTE: For high altitude installations, calculate the input rate in accordance with the procedure in the HIGH ALTITUDE INSTALLATIONS in the OPERATING INSTRUCTIONS section.

1. Attach a pressure gauge or a manometer to the gauge port. Check for correct manifold pressure. PRESSURE SHOULD NOT EXCEED VALUE INDICATED ON RATING PLATE.
2. Use this formula to "clock" the meter. Be sure that other gas consuming appliances are not ON during this interval.

$$\frac{3600}{T} \times H = \text{Btuh}$$

T = Time in seconds to burn one cubic foot of gas.

H = Gas heating value (Btu per cubic foot of gas).

Btuh = Actual boiler input per hour.

IMPORTANT

UNDER NO CIRCUMSTANCES SHALL THE GAS PRESSURE MEASURED AT THE BURNER MANIFOLD EXCEED THAT STATED ON THE BOILER RATING PLATE. OVERFIRING WILL RESULT IN DAMAGE TO THE BOILER, AS WELL AS INCREASED RISK OF FIRE, SOOTING AND ASPHYXIATION.

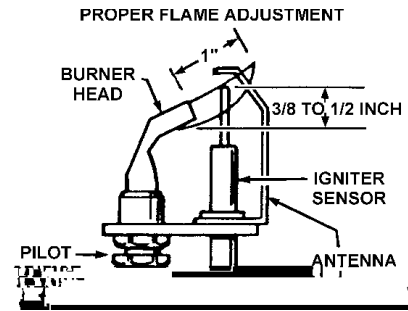

FIGURE 26

PILOT BURNER

The pilot flame should envelop 3/8 to 1/2 inch (10 to 12 mm) of the top of the insulated rod on the pilot burner, fig. 26. Normally, the pilot flame will be correct when the pilot manual valve is in the full "ON" position. Check pilot burner every 3 months for proper flame characteristics.

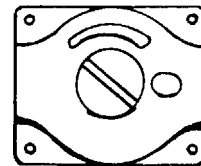
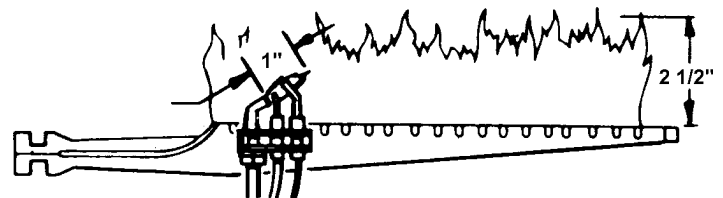

FIGURE 27

To adjust the pilot flame, remove the screw on the pilot gas regulator, fig. 27, to expose the adjustment screw. Turn the adjusting screw clockwise to increase the length of the flame or counterclockwise to decrease the length of the flame.

MAIN BURNER

Check main burner every three months for proper flame characteristics, fig. 28.



TYPICAL AND MAIN BURNER FLAMES
FIGURE 28

The main burner should display the following characteristics:

- Provide complete combustion of gas.
- Cause rapid ignition and carryover of flame across entire burner.
- Give reasonably quiet operation during initial ignition, operation and extinction.
- Cause no excessive lifting of flame from burner ports.

If the preceding burner characteristics are not evident, check for accumulation of lint or other foreign material that restricts or blocks the air openings to the burner or boiler.

NOTE: Cleaning of main burners.

Shut off all gas and electric to unit.

Complete burner tray assembly may be removed by disconnecting union assembly, pilot line connection at main burner and sliding tray out of cabinet.

1. Remove main burners from unit.
2. Check that burner venturi and ports are free of foreign matter.
3. Clean burners with bristle brush and/or vacuum cleaner 3/4" DO NOT distort burner ports or pilot location.
4. Reinstall burners in unit. Making sure front and rear of burners are installed correctly in burner support brackets.

Also check for good flow of combustion and ventilating air to the unit. Maintain a clear area around the boiler at all times.

After placing the boiler in operation check the ignition system safety shutoff devices for proper operation. To accomplish this with the main burners operating, close the pilot adjusting valve on the left side of the manifold. Within four seconds the main burners and pilot should extinguish and the spark igniter on the pilot assembly should begin sparking. If this does not occur immediately, discontinue gas supply by closing main manual shutoff and call a qualified serviceman to correct the situation. If the burners extinguish, and pilot assembly begins sparking, the system is operating correctly so discontinue electrical power, open pilot adjusting valve, and light boiler in accordance with lighting and operating instructions.

For installations above 2000 feet (600 m), refer to HIGH ALTITUDE INSTALLATIONS in the installation section.

PRE-TROUBLE-SHOOTING

Before any extensive trouble-shooting, perform the following:

Ensure that:

- Power (120 vac) is supplied to the appliance.
- System control (tank temperature control, thermostat, etc.) is calling for appliance operation (call for heat).
- Other contacts (switches) are closed (transformer relay, low water cutoff, flow switch, limit controls, pressure switches, etc.)
- Gas supply pressure is within the maximum and minimum operating ranges listed on the appliance rating plate/label.
- Voltage (24 vac) is supplied by transformer.
- Appliance is wired according to wiring diagram.

NOTE: Cross wiring the 24 volt circuit of the relay will short the transformer.

- All wire terminals/connectors are firmly attached to valves, modules, switches, limit controls, etc.
- There has been no damage caused by freezing, inoperative pumps, etc.

TROUBLE-SHOOTING

CHECKOUT SEQUENCE	SYSTEM OPERATION		CAUSE	REMEDY
	CORRECT	INCORRECT		
Set tank/system temperature control (thermostat) 20°F (12°C) below tank water temperature.	Circulating pump and burner shutoff.	Pump and burner remain on.	Temp. control (thermostat) defective.	Replace.
			System wiring incorrect	Correct wiring.
	With thermal balancer, pump off delay of approximately two minutes.	Circulating pump on.	Pump wired for continuous operation.	Correct wiring.
		Burner on.	Gas valve stuck or defective.	Correct or replace valve.
Set tank/system temperature control (thermostat) 20°F (12°C) above tank/system water temperature.	Circulating pump and burner on.	Circulating pump on.	Auto reset high limit control set too low.	Replace. (If problem proven to be at this control by applying jumper to terminals).
			Auto reset high limit control differential too wide.	
			System wiring is incorrect.	Correct wiring.
			Manual reset high limit switch has activated.	Depress reset button.
	Circulating pump and burner off.	Circulating pump and burner off.	Gas valve or wiring defective.	
			Power off or system wiring is incorrect.	Check power supply and wiring.
			Temp. control (thermostat) defective.	Replace.
			Burner on.	System wiring is incorrect.
Boiler outlet temperature exceeds 210°F (98°C) hot water supply, 250°F (120°C) hydronic supply.	Circulating pump.	Circulating pump and burner on.	Auto reset high limit control defective, or set too high (max. should be set at 200°F [93°C] hot water supply, 240°F [115°C] hydronic supply).	Replace.
Set tank/system temperature control (thermostat) for desired water temperature.	System maintains desired water temperature.			

CHECKING HONEYWELL S8600H OR S8610M (NAT. GAS) INTERMITTENT IGNITION CONTROLS

NO SPARK AT PILOT BURNER

Replace ignition module

NO

Is voltage (24 Vac) across the 24 V terminals on module during "call for heat"?

YES

NO

Is voltage (24 Vac) across the PV & MV/PV terminals on "call for heat"?

NOTE: S8610M will automatically reset every five (5) minutes. For S8600H pilot valve will be de-energized if module goes into lockout condition. Reset system by turning electrical power off or by turning system controller to off

SPARK AT PILOT BURNER BUT PILOT WILL NOT LIGHT

Ensure all manual shutoff valves are fully open; All filters are clean; All gas connections are gas tight; Pilot tubing is not damaged, obstructed or kinked; and pilot orifice is unclogged. Check for air in gas line, purge (bleed) line if necessary.

Are the wires securely attached to the pilot operator on the gas control and to the PV & MV/PV terminals on the ignition module?
 YES
 NO → Attach wires firmly.

Install a pressure gauge in the pilot tubing line between the gas control and the pilot burner assembly. Ensure that the pilot adjustment screw (under cap) is adjusted to a position that will permit gas to flow. Is pilot gas flowing during ignition attempt?
 YES
 NO → Replace gas valve.

Turn off power supply.

Is ignition cable firmly plugged into pilot assembly and module? Is ground wire firmly attached to pilot assembly and GND terminal on module?
 YES
 NO → Securely connect cable and/or ground wire.

Are ignition cable and ground wire in good condition (not brittle, burnt, or cracked)?
 YES
 NO → Replace cable and/or ground wire.

Ensure ground strap is the closest metal to the igniter/sensor rod (electrode) to prevent the spark from shorting out to other metal parts (pilot screen, pilot shield, etc.). Ignition cable must not touch metal surfaces or current carrying wires. Is there a 1/8" gap between ground strap and electrode?
 YES
 NO → Carefully bend downwards top of ground strap to achieve 1/8" spark gap.

Is the ceramic insulator surrounding the electrode in good condition (not cracked or broken)?
 YES
 NO → Replace pilot burner.

Is there excessive draft conditions that may cause pilot burner ignition problems?
 YES
 NO → Replace ignition module.

Correct draft problems in a manner that would ensure adequate combustion and ventilation air and proper pilot burner performance.

PILOT BURNER LIGHTS BUT MAIN BURNER DOES NOT LIGHT

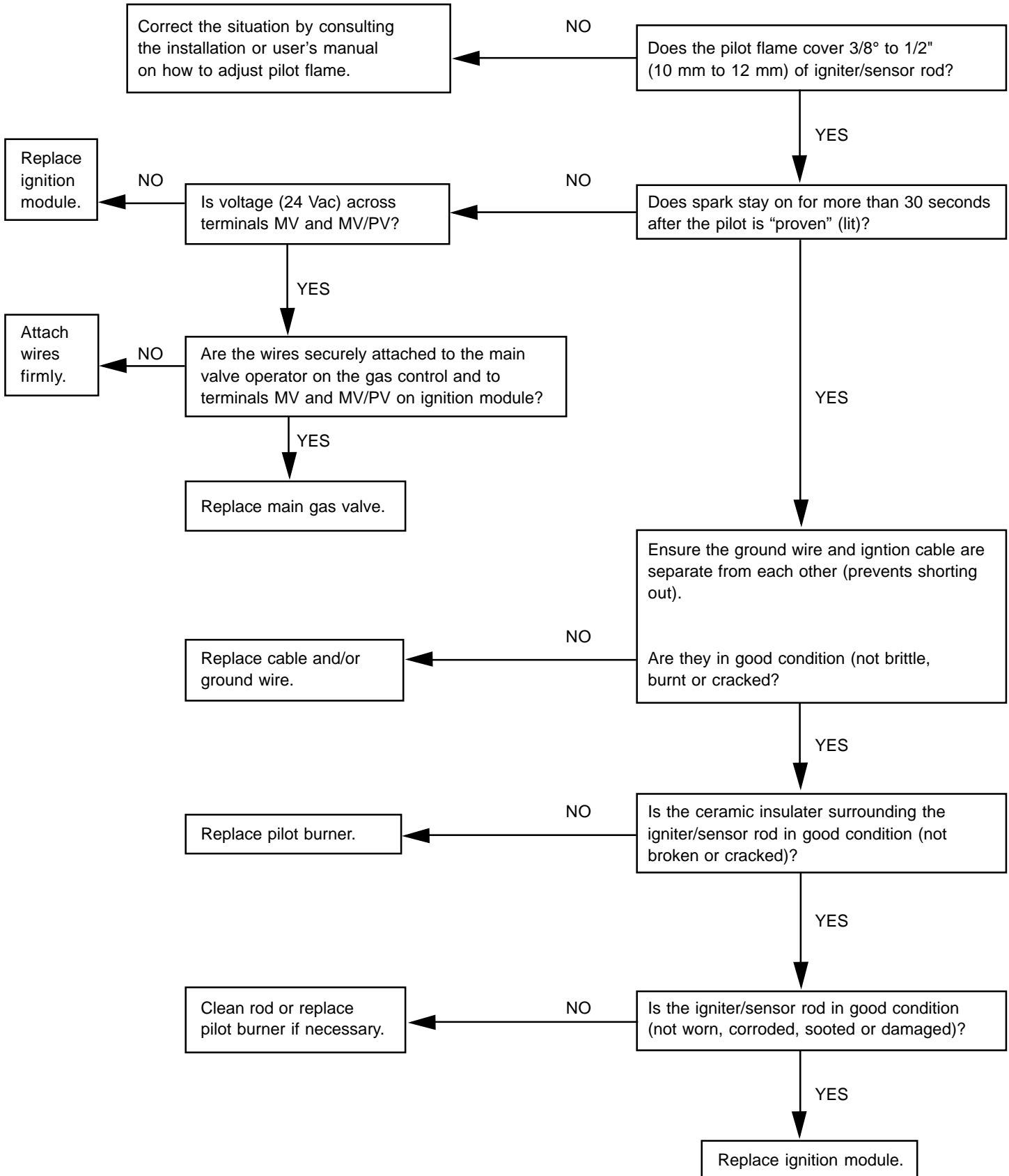

GENERAL MAINTENANCE

These boilers are designed to give many years of efficient and satisfactory service when properly operated and maintained. To assure continued good performance, the following recommendations are made.

The area around the unit should be kept clean and free from lint and debris. Sweeping the floor around the boiler should be done



DO NOT USE A NYLON BRUSH OR OTHER STATIC CREATING MATERIAL TO CLEAN DUST AND CARBON DEPOSITS FROM HEATING SURFACES AND VENT.

SUCH DEPOSITS ARE FLAMMABLE AND MAY BE IGNITED BY STATIC ELECTRICITY. USE A METAL BRUSH TO MINIMIZE THE DANGER OF EXPLOSION

1. Turn off the electrical power, main manual gas shutoff and pilot valves.
 - Allow boiler parts to cool before disassembly.
2. Remove the internal flue collector and vent pipe running to the chimney.
 - Check parts and chimney for obstructions and clean as necessary.
3. Remove burners from boiler and other metal parts as required to clean as necessary.
 - Refer to parts list supplied with this manual for disassembly aid.
4. Clean and reinstall the parts removed in steps 2 and 3.
 - Be sure the vent pipe has a minimum upward pitch of one quarter inch per foot of length and is sealed as necessary.
5. Restore electrical power and gas supply to boiler.
 - Check for gas leaks and proper boiler and vent operation.

HEAT EXCHANGER PREVENTIVE MAINTENANCE

In most water supply systems some solids exist. As the water is heated, these tend to drop out depositing as scale or lime. This scale is relatively easy to remove before the unit becomes clogged.



Lime accumulation can reduce the life of the equipment, reduce efficiency and waste fuel. Boiler failure due to lime or scale build-up voids the warranty.

See section on CIRCULATING PUMP to ensure you have selected the proper size pump for your situation.

DELIMING

The amount of calcium carbonate (lime) released from water is in direct proportion to water temperature and usage. The higher the water temperature or water usage, the more lime deposits are dropped out of the water. This is the lime scale which forms in pipes, boilers and on cooking utensils.

The usage of water softening equipment greatly reduces the hardness of water. However, this equipment does not always remove all of the hardness (lime). For this reason it is recommended that a regular schedule for deliming be maintained.

Figure 29 shows typical piping arrangement for gravity deliming of lime deposits. For systems using recirculating deliming pumps contact your A. O. Smith distributor.

Lime build-up may be seen when viewing the interior of the inlet/outlet manifold through the pressure relief valve tapping.

The time between cleaning will vary from two to six months depending upon water conditions and usage. A change of approximately 5°F in the normal temperature rise through the boiler is usually an indication that scale should be removed. For long life, copper or brass is recommended for all valves, pipe and fittings used between gate valves "A" and "B" and the boiler, see fig. 29.

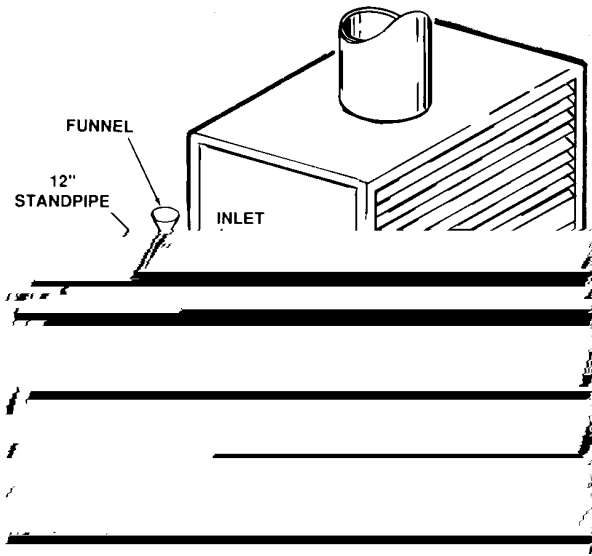

DELIMING SOLVENTS

A. O. Smith recommends the use of UN•LIME for deliming. UN•LIME is a patented food grade acid.

UN•LIME may be obtained from your dealer, distributor or the A.O. Smith Water Products Company, Part No. 4763 (1 gal. [4 L]) packed 4 gallons (16 L) per case, Part No. 4813 (5 gal. [20 L]) single container.



Read the instructions on the label of the UN•LIME container.

REMOVING LIGHT DEPOSITS OF SCALE

1. Shut off electric and gas supply to the burner.
2. Close gate valves "A" and "B", see fig. 29.
3. Open drain cock and drain unit.
4. Install standpipe in tee of inlet/outlet line, see fig. 29.
5. Close drain cock.
6. Slowly pour required amount of UN•LIME shown in table below into unit through standpipe. Direct solution into suitable container with hose.
7. Continue to fill until foaming action stops. For heavy deposits pour through twice.
8. When foaming action has stopped completely, allow 10 to 15 minutes for UN•LIME to dissolve any remaining scale in the unit.
9. Open the drain cock and drain all UN•LIME from unit.
10. Remove 12" standpipe and install plug fitting. Close drain cock. Open valve "A" allowing fresh water to flow through unit and drain out hose for 5 minutes.
11. Close valve "A", open drain cock, remove standpipe and hose assembly and install plug fitting.

12. Close drain cock and open valves "A" and "B". Purge system of air. Restore electric and gas supply.

AMOUNT OF UN•LIME REQUIRED	
720, 840, 960, 1080	3 gallons (12 L)
1210, 1350	4 gallons (16 L)
1480, 1610, 1810	6 gallons (24 L)

MECHANICAL REMOVAL OF DEPOSITS

To service heat exchanger tubes remove cover panel from far side of water connections. This will expose the heat exchanger return bends. Return bends may be removed using a standard 9/16" deep socket ratchet exposing the tube ends. Inspect to ensure tubes are free of scale and deposits. If scaled, remove deposits with a stiff wire brush or mechanical tube cleaner to bare metal. Install new "O" rings and install return bends. Flush system.

REMOVAL OF AN EXISTING BOILER FROM A COMMON VENTING SYSTEM

At the time of removal of an existing boiler, the following steps shall be followed with each appliance remaining connected to the common existing system placed in operation, while the other appliances remaining connected to the common venting system are not in operation.

Seal any unused openings in the common venting system.

Visually inspect the venting system for proper size and horizontal pitch and determine there is no blockage or restriction, leakage, corrosion and other deficiencies which could cause an unsafe condition.

Insofar as is practical, close all building doors and windows and all doors between the space in which the appliance remaining connected to the common venting system are located and other spaces of the building. Turn on clothes dryers and any appliance not connected to the common venting system. Turn on any exhaust fans, such as range hoods and bathroom exhausts, so they will operate at maximum speed. Do not operate a summer exhaust fan. Close fireplace dampers.

Place in operation the appliance being inspected. Follow the lighting instructions. Adjust thermostat so appliance will operate continuously.

Test for spillage at the draft hood relief opening after 5 minutes of main burner operation. Use the flame of a match or candle, or smoke from a cigarette, cigar or pipe.

After it has been determined that each appliance remaining connected to the common venting system properly vents when tested as outlined above, return doors, windows, exhaust fans, fireplace dampers and any other gas-burning appliance to their previous condition of use.

Any improper operation of the common venting system should be corrected so the installation conforms with the National Fuel Gas Code, ANSI Z223.1 and/or CAN/CSA B149, Installation Codes. When resizing any portion of the common venting system, the common venting system, the common venting system should be resized to approach the minimum size as determined using the appropriate tables in Appendix F in the National Fuel Gas Code, ANSI Z223.1 and/or CAN/CSA B149 Installation Codes.

DURA-MAX LIMITED WARRANTY

A. O. Smith Corporation, the warrantor, extends the following LIMITED WARRANTY to the owner of this hydronic boiler:

1. If within TEN years after initial installation of the boiler, the heat exchanger shall prove upon examination by the warrantor to be defective in material or workmanship, the warrantor, at his option will exchange or repair such part or portion. This term is reduced to FIVE years if this boiler is used for volume hot water supply purposes other than hydronic space heating.
 - a. This warranty is extended to the owner for all other parts or portion during the FIRST year following initial installation of this boiler.
 - b. The warranty on the repair or replacement of the part or portion will be limited to the unexpired term of the original warranty.

2. CONDITIONS AND EXCEPTIONS

This warranty shall apply only when the boiler is installed in accordance with local plumbing and building codes, ordinances and regulations, the printed instructions provided with it and good industry practices. In addition, an appropriately sized safety relief valve certified to the ASME Boiler and Pressure Vessel Code must have been installed and fresh water used for filling and makeup purposes;

- a. This warranty shall apply only when the boiler is used:
 - (1) owned by the original purchaser;
 - (2) in its original installation location;
 - (3) sized in accordance with proper sizing techniques for commercial boilers;
 - (4) bearing a rating plate which has not been altered, defaced or removed except as required by the warrantor;
 - (5) fired at the factory rated input using the fuel stated on the rating plate;
 - (6) maintained in accordance with the instructions printed in the manual included with the heater.
 - (7) at temperatures not exceeding the maximum setting of its operative and/or high limit control;
 - (8) at water pressure not exceeding the working pressure shown on the boiler;
 - (9) when filled with boiler water, free to circulate at all times and with the heat exchanger free of damaging scale deposits;
 - (10) in a non-corrosive and non-contaminated atmosphere;
 - (11) in the United States, its territories or possessions, and Canada;
 - (12) at a water velocity flow rate, not exceeding or below the boiler's designed rates;
 - (13) indoor installation only.
- b. Any accident to the boiler, any misuse, abuse (including freezing) or alteration of it, any operation of it in a modified form will void this warranty.

3. SERVICE AND REPAIR EXPENSE

Under this limited warranty the warrantor will provide only a replacement part. The owner is responsible for all other costs. Such costs may include but are not limited to:

- a. Labor charges for service removal, repair or reinstallation of the component part;
 - b. Shipping, delivery, handling, and administrative charges for forwarding the replacement part from the nearest distributor and returning the claimed defective part to such distributor.
 - c. All cost necessary or incidental for any material and/or permits required for installation of the replacement.
- ### 4. LIMITATIONS ON IMPLIED WARRANTIES
- Implied warranties, including any warranty of merchantability imposed on the sale of this boiler under state law are limited to one (1) year duration for the boiler or any of its parts. Some states or provinces do not allow limitations on how long an implied warranty lasts, so the above limitation may not apply to you.

5. CLAIM PROCEDURE

Any claim under the warranty should be initiated with the dealer who sold the boiler, or with any other dealer handling the warrantor's products. If this is not practical, the owner should contact:

U.S. Customers

A. O. Smith Corporation
5621 West 115th Street
Alsip, IL 60803
Telephone: 800 323-2636

Canadian Customers

A. O. Smith Enterprises Ltd.
P. O. Box, 310 - 768 Erie Street
Stratford, Ontario N5A 6T3
Telephone: 800 265-8520

- a. The warrantor will only honor replacement with identical or similar parts thereof which are manufactured or distributed by the warrantor.



REPLACEMENT PARTS

A. O. SMITH
WATER PRODUCTS
COMPANY

5621 W. 115TH STREET, ALSIP, IL 60803
PHONE: 800-433-2545 FAX: 800-433-2515
www.hotwater.com E-Mail: parts@hotwater.com