



GAS WATER HEATERS OWNER'S MANUAL

Thank you for buying this energy efficient water heater from A.O. Smith Water Products Company. We appreciate your confidence in our products.

You should thoroughly read this manual before installation and/or operation of this water heater. Please pay particular attention to the important safety and operating instructions as well as the WARNING and CAUTIONS.

GAS MODELS FPSH - 75 Series 271 with Hot Surface Ignition



WARNING: If the information in these instructions is not followed exactly, a fire or explosion may result causing property damage, personal injury or death.

— Do not store or use gasoline or other flammable vapors and liquids in the vicinity of this or any other appliance.

— **WHAT TO DO IF YOU SMELL GAS**

- Do not try to light any appliance.
- Do not touch any electrical switch; do not use any phone in your building.
- Immediately call your gas supplier from a neighbor's phone. Follow the gas supplier's instructions.
- If you cannot reach your gas supplier, call the fire department.

— Installation and service must be performed by a qualified installer, service agency or the gas supplier.

TABLE OF CONTENTS

	PAGE
GET TO KNOW YOUR WATER HEATER	2
GENERAL SAFETY INFORMATION	3-4
INSTALLATION	4-12
OPERATION	12-14
MAINTENANCE AND TROUBLESHOOTING	14-17
TROUBLESHOOTING WITH THE LED	18
WARRANTY	19

CAUTION

TEXT PRINTED OR OUTLINED IN RED CONTAINS INFORMATION RELATIVE TO YOUR SAFETY. PLEASE READ THOROUGHLY BEFORE INSTALLING AND USING THIS APPLIANCE.



A DIVISION OF A.O. SMITH CORPORATION
www.hotwater.com

KEEP THIS MANUAL IN THE POCKET ON THE HEATER FOR FUTURE REFERENCE
WHENEVER MAINTENANCE ADJUSTMENT OR SERVICE IS REQUIRED.



GET TO KNOW YOUR WATER HEATER

REPLACEMENT PARTS AND DELIMING PRODUCTS

Replacement parts and recommended delimer may be ordered through authorized servicers or distributors. Refer to the Yellow Pages for your A. O. Smith plumber or contact the A. O. Smith Water Products Company, 5621 W. 115th Street, Alsip, IL 60803, 1-800-433-2545. When ordering parts, provide complete model and serial numbers (see rating plate), quantity and name of part desired, as listed in Figure 1. Standard hardware items may be purchased locally.

- | | |
|------------------------------------|---|
| (A) VENT PIPE | (P) TEMPERATURE AND PRESSURE RELIEF VALVE |
| (B) ANODE | (Q) EMBLEM AND RATING PLATE |
| (C) HOT WATER OUTLET | (R) INSULATION |
| (D) OUTLET (120 VAC) | (S) VENT TERMINAL |
| (E) FLUE BAFFLE | (T) DRAIN VALVE |
| (F) GAS SUPPLY | (U) IGNITER AND MAIN BURNER |
| (G) MAIN MANUAL GAS SHUT OFF VALVE | (V) FLUE |
| (H) GROUND JOINT UNION | (W) DRAIN PAN |
| (J) DIRT LEG | (X) GAS VALVE |
| (K) OUTER DOOR | (Y) CONTROL HARNESS* |
| (L) UNION | (Z) AIR MIXING BOX |
| (M) INLET WATER SHUT OFF VALVE | (AA) MOTOR & BLOWER |
| (N) COLD WATER INLET | (BB) DISCHARGE AIR ECO |
| (O) INLET DIP TUBE | (CC) CONDENSATE FITTING |

***CAUTION HARNESS HAS 120 VAC. IN OPERATION**

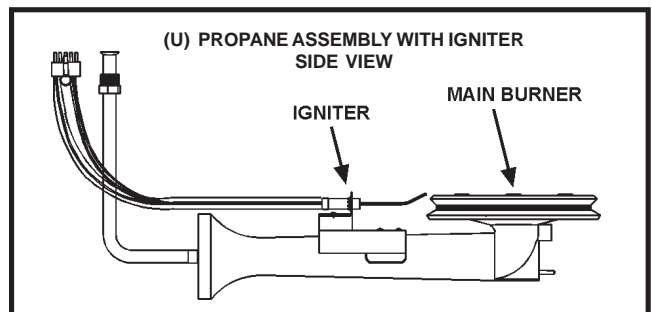
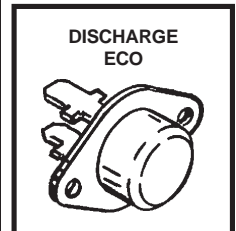
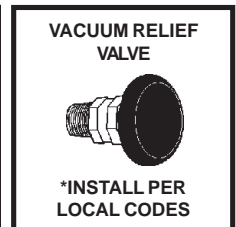
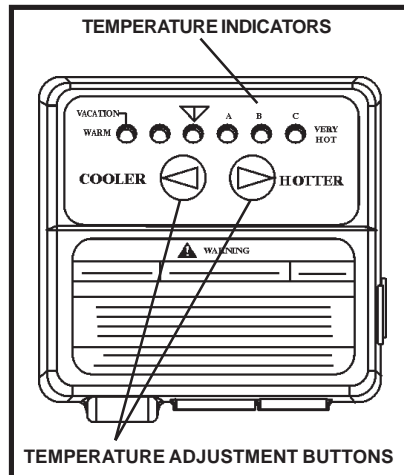
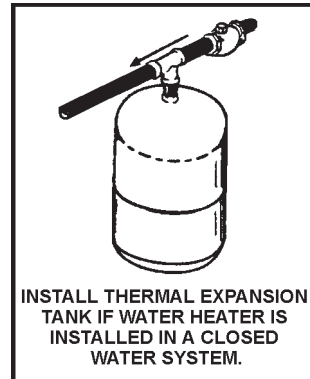
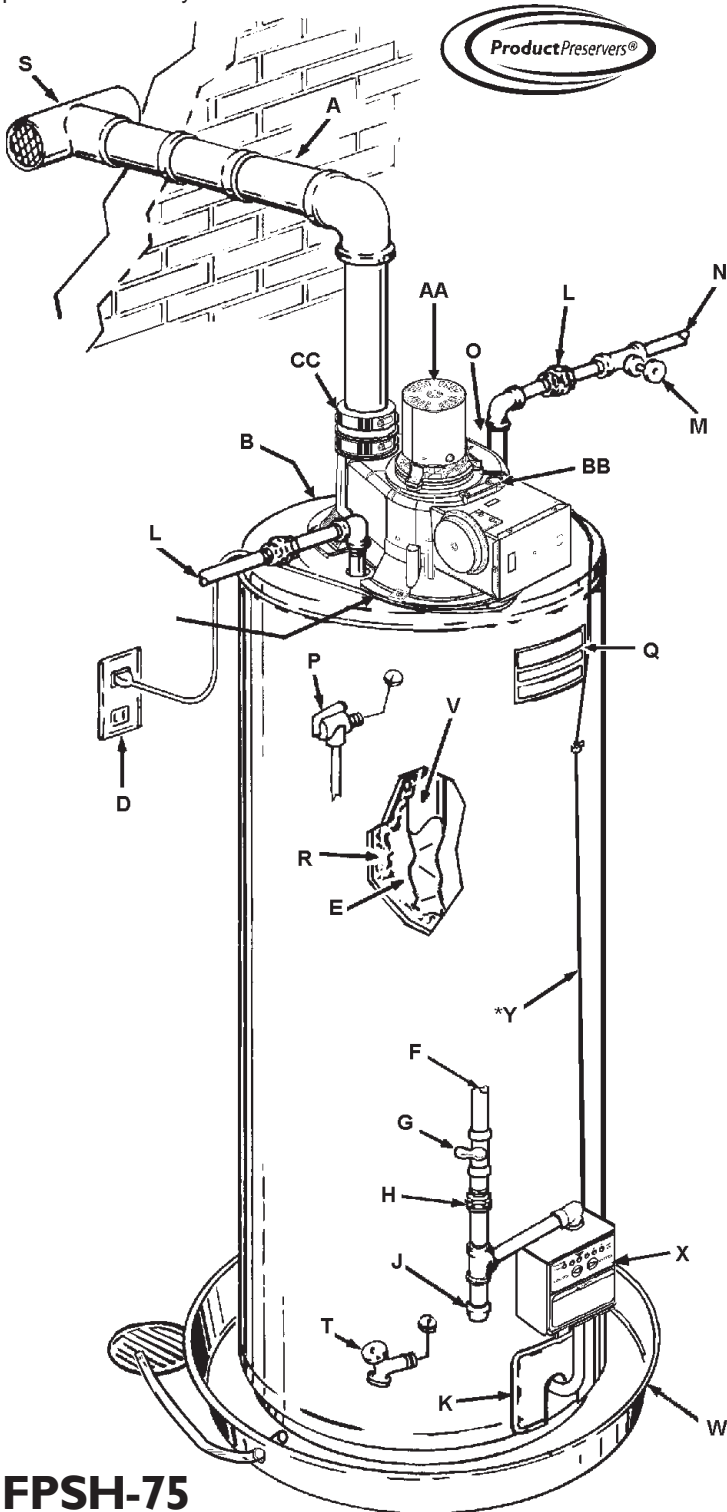

FPSH-75
with Hot Surface Ignition

FIGURE 1

A. O. SMITH
WATER PRODUCTS
COMPANY





GENERAL SAFETY INFORMATION

EXTERNAL DAMAGE

Do not operate the water heater until it has been fully checked out by a qualified technician, if the water heater:

- Has been exposed to fire or damage.
- Displays evidence of sooting.
- Produces steam or unusually hot water.

If the water heater has been subject to flooding it must be replaced.

CHEMICAL VAPOR CORROSION



CORROSION OF THE FLUEWAYS AND VENT SYSTEM MAY OCCUR IF AIR FOR COMBUSTION CONTAINS CERTAIN CHEMICAL VAPORS. SUCH CORROSION MAY RESULT IN FAILURE AND RISK OF ASPHYXIATION.

Spray can propellants, cleaning solvents, refrigerator and air conditioning refrigerants, swimming pool chemicals, calcium and sodium chloride (water softener salt), waxes, and process chemicals are typical compounds which are potentially corrosive.

Do not store products of this sort near the heater. Also, air which is brought in contact with the heater should not contain any of these chemicals. If necessary, uncontaminated air should be obtained from remote or outside sources. The limited warranty is voided when failure of water heater is due to a corrosive atmosphere. (See limited warranty for complete terms and conditions).

IMPROPER COMBUSTION



ATTIC AND/OR EXHAUST FANS OPERATING ON THE PREMISES WITH A WATER HEATER CAN RESULT IN CARBON MONOXIDE POISONING AND DEATH.

OPERATION OF THESE FANS CAN PRODUCE A NEGATIVE DRAFT IN THE AREA OF THE WATER HEATER PREVENTING THE PRODUCTS OF COMBUSTION FROM EXHAUSTING THROUGH THE VENT PIPE.

The venting of the water heater should be inspected by a qualified service technician at the time of installation and periodically thereafter to ensure a down-draft condition does not exist.

DO NOT OBSTRUCT THE FLOW OF COMBUSTION AND VENTILATING AIR. ADEQUATE AIR FOR COMBUSTION AND VENTILATION MUST BE PROVIDED FOR SAFE OPERATION.

LIQUID PETROLEUM MODELS



Water heaters for propane or liquefied petroleum gas (LPG) are different from natural gas models. A natural gas heater will not function safely on LP gas and no attempt should be made to convert a heater from natural gas to LP gas.

LP gas must be used with great caution. It is highly explosive and heavier than air. It collects first in the low areas making its odor difficult to detect at nose level. If LP gas is present or even suspected, do not attempt to find the cause yourself. Go to a neighbor's house, leaving your doors open to ventilate the house, then call your gas supplier or service agent. Keep area clear until a service call has been made.

At times you may not be able to smell an LP gas leak. One cause is odor fade, which is a loss of the chemical odorant that gives LP gas its distinctive smell. Another cause can be your physical condition, such as having a cold or a diminishing sense of smell with age. For these reasons, the use of a propane gas detector is recommended.

IF YOU EXPERIENCE AN OUT-OF-GAS SITUATION, DO NOT TRY TO RELIGHT APPLIANCES YOURSELF. Ask your LP delivery person to relight pilots for you. Only trained LP professionals should conduct the required safety checks in accordance with industry standards.

EXTENDED NON-USE PERIODS



HYDROGEN GAS CAN BE PRODUCED IN A HOT WATER SYSTEM SERVED BY THIS HEATER THAT HAS NOT BEEN USED FOR A LONG PERIOD OF TIME (GENERALLY TWO WEEKS OR MORE). HYDROGEN GAS IS EXTREMELY FLAMMABLE. To reduce the risk of injury under these conditions, it is recommended that the hot water faucet be opened for several minutes at the kitchen sink before using any electrical appliance connected to the hot water system. If hydrogen is present, there will probably be an unusual sound such as air escaping through the pipe as the water begins to flow. **THERE SHOULD BE NO SMOKING OR OPEN FLAME NEAR THE FAUCET AT THE TIME IT IS OPEN.**

INSULATION BLANKETS

Insulation blankets available to the general public for external use on gas water heaters are not necessary with A.O. Smith products. The purpose of an insulation blanket is to reduce the standby heat loss encountered with storage tank heaters. Your A.O. Smith water heater meets and exceeds the ASHRAE/IES 90.1b-1992 standards with respect to insulation and standby loss requirements, making an insulation blanket unnecessary.



Should you choose to apply an insulation blanket to this heater, you should follow these instructions (See Figure 1 for identification of components mentioned below). Failure to follow these instructions can restrict the air flow required for proper combustion, potentially resulting in fire, asphyxiation, serious personal injury or death.

- Do not cover the gas valve or temperature & pressure relief valve.
- Do not allow insulation to come within 2" of the dilution air inlet on the blower, to prevent blockage of the dilution air.
- Do not allow insulation to come within 2" of the floor to prevent blockage of combustion air flow to the burner.

- **Do not** cover the instruction manual. Keep it on the side of the water heater or nearby for future reference.
- **Do** obtain new warning and instruction labels from A.O. Smith for placement on the blanket directly over the existing labels.
- **Do** inspect the insulation blanket frequently to make certain it does not sag, thereby obstructing combustion air flow.



INSTALLATION

REQUIRED ABILITY

INSTALLATION OR SERVICE OF THIS WATER HEATER REQUIRES ABILITY EQUIVALENT TO THAT OF A LICENSED TRADESMAN IN THE FIELD INVOLVED. PLUMBING, ELECTRICAL AIR SUPPLY, VENTING AND GAS SUPPLY ARE REQUIRED.

GENERAL

The heater is designed to operate on natural or propane gases. HOWEVER, MAKE SURE the gas on which the heater will operate is the same as that specified on the heater model and rating plate.

The installation must conform to these instructions and the local code authority having jurisdiction. In the absence of local codes, the installation must conform to the latest edition of National Fuel Gas Code ANSI Z223.1/NFPA 54 and the National Electric Code, NFPA 70. The former is available from the Canadian Standards Association, 8501 East Pleasant Valley Road, Cleveland, OH 44131, and both documents are available from the National Fire Protection Association, 1 Batterymarch Park, Quincy, MA 02269.

GROUNDING

The water heater, when installed, must be grounded in accordance with local codes, or in the absence of local codes:

In the United States

The National Electric Code, ANSI/NFPA 70.

HIGH ALTITUDE INSTALLATION



CAUTION

INSTALLATIONS ABOVE 2000 FT. REQUIRE REPLACEMENT OF THE BURNER ORIFICE IN ACCORDANCE WITH THE NATIONAL FUEL GAS CODE (ANSI Z223.1/NFPA 54). FAILURE TO REPLACE THE ORIFICE COULD RESULT IN IMPROPER AND INEFFICIENT OPERATION OF THE APPLIANCE, PRODUCING CARBON MONOXIDE GAS IN EXCESS OF SAFE LIMITS, WHICH COULD RESULT IN SERIOUS PERSONAL INJURY OR DEATH. CONTACT YOUR GAS SUPPLIER FOR ANY SPECIFIC CHANGES WHICH MAY BE REQUIRED IN YOUR AREA.

A.O. SMITH BUILDS SOME MODELS SPECIFICALLY FOR HIGH ALTITUDE SERVICE.

PLEASE CHECK THE RATING PLATE BEFORE MAKING CHANGES.

LOCATION OF HEATER

When installing the heater, consideration must be given to proper location. Location selected should be as close to the wall as practicable with adequate air supply and as centralized with the water piping system as possible.

The heater is design certified by the Underwriter's Laboratory for installation on combustible flooring in a closet having minimum clearances from combustible material of: 0" clearance from sides and rear, 5" from the front and 12" from the top. (Standard clearance.) If clearances stated on the heater differ from standard clearances, install water heater according to clearances stated on heater.

A minimum clearance of 4" must be allowed for access to replaceable parts such as the thermostats, drain valve and relief valve. A top clearance of 24" should be allowed for blower assembly service.

Adequate clearance for servicing this appliance should be considered before installation, such as changing the anodes, etc. Minimum clearances for proper operation are given above.



WARNING

In cold climates provide protection against freeze-up.

THE HEATER SHOULD BE LOCATED IN AN AREA WHERE LEAKAGE OF THE TANK OR CONNECTIONS WILL NOT RESULT IN DAMAGE TO THE AREA ADJACENT TO THE HEATER OR TO LOWER FLOORS OF THE STRUCTURE. When such locations cannot be avoided, a suitable drain pan should be installed under the heater, see Figure 1. The pan must not restrict combustion air flow. Such pans should have a minimum length and width of at least 2 inches greater than the diameter of the heater and should be piped to an adequate drain. Drain pans suitable for these heaters are available from your dealer or A. O. Smith Water Products Company, 5621 W. 115th Street, Alsip, Illinois 60803.



WARNING

DO NOT INSTALL THIS WATER HEATER DIRECTLY ON A CARPETED FLOOR. A FIRE HAZARD MAY RESULT. Instead the water heater must be placed on a metal or wood panel extending beyond the full width and depth by at least 3 inches (76.2mm) in any direction. If the heater is installed in a carpeted alcove or closet, the entire floor shall be covered by the panel.

AIR REQUIREMENTS

In calculating the free area of a vent opening, the blocking effect of screens, louvers and grills should be considered. Screens shall not be of a mesh smaller than 1/4 inch square. If the free area is not known, the latest edition of National Fuel Gas Code ANSI Z223.1 recommends using figures of 20-25 percent free area for wood louvers or 60-75 percent for metal grills or louvers.

UNCONFINED SPACE

In buildings of conventional frame, brick or stone construction, unconfined spaces may provide adequate air for combustion, ventilation, and dilution air for power venter.

If the unconfined space is within a building of tight construction (building using the following construction: weather stripping, heavy insulation, caulking, vapor barrier, etc.), air for combustion, ventilation, and venter dilution must be obtained from outdoors. The installation instructions for confined spaces must be followed.

CONFINED SPACE

When drawing combustion and dilution air from inside a conventionally constructed building to a confined space, such a space shall be provided with two permanent openings. ONE WITHIN 12 INCHES OF THE ENCLOSURE TOP AND ONE WITHIN 12 INCHES OF THE ENCLOSURE BOTTOM. Each opening shall have a free area of one square inch per 1000 Btuh of the total input of all appliances in the enclosure, but not less than 100 square inches.

If the confined space is within a building of tight construction, air for combustion, ventilation and power venter dilution must be obtained from outdoors. When directly communicating with the outdoors or communicating through vertical ducts, two permanent openings, located in the above manner, shall be provided. Each opening shall have a free area of not less than one square inch per 4000 Btuh of the total input of all appliances in the enclosure. If horizontal ducts are used, each opening shall have a free area of not less than one square inch per 2000 Btuh of the total input of all appliances in the enclosure.

⚠ DANGER



⚠ Vapors from flammable liquids may explode and catch fire causing death or severe burns.

Water heater has a main burner and hot surface igniter. The hot surface igniter:

1. can come on at any time and
2. will ignite flammable vapors.

Do not use or store flammable products such as gasoline, solvents or adhesives in the same room or area near the water heater.

Vapors:

1. cannot be seen,
2. are heavier than air,
3. go a long way on the floor and
4. can be carried from other rooms to the pilot flame by air currents.

Keep flammable products:

1. far away from heater,
2. in approved containers,
3. tightly closed and
4. out of children's reach.

Installation:

Do not install water heater where flammable products will be stored or used unless the main burner and pilot

flames are at least 18" above the floor. This will reduce, but not eliminate, the risk of vapors being ignited by the main burner or pilot flame.

WATER CONNECTIONS

Refer to Figure 1 for typical installation. A suitable pipe thread sealant must be used to prevent leakage.

WATER (POTABLE) HEATING AND SPACE HEATING

1. All piping components connected to this unit for space heating applications shall be suitable for use with potable water.
2. Toxic chemicals, such as those used for boiler treatment, shall NEVER be introduced into this system.

3. This unit may NEVER be connected to any existing heating system or component(s) previously used with a non-potable water heating appliance.
4. When the system requires water for space heating at temperatures higher than required for domestic water purposes, a tempering valve must be installed. Please refer to Figure 2 for suggested piping arrangement.

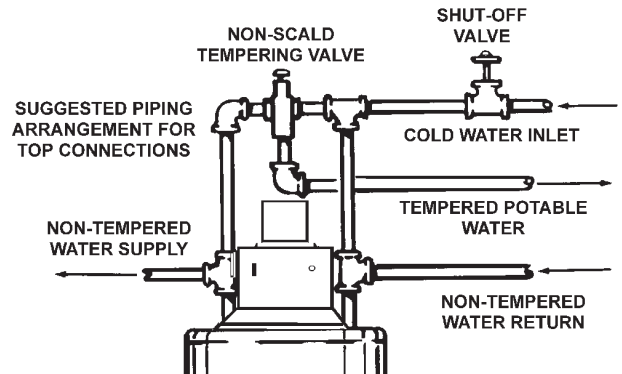

FIGURE 2

CLOSED WATER SYSTEM

A closed system will exist if a back-flow preventer (check valve), pressure reducing valve, or other similar device is installed in the cold water line between the water heater and the street main (or well). Excessive pressure may develop due to the thermal expansion of heated water causing premature tank failure or intermittent relief valve operation. This type of failure is not covered by the limited warranty. An expansion tank may be necessary in the cold water supply to alleviate this situation, see Figure 1. Contact the local plumbing authority.

If the temperature and pressure relief valve on the appliance discharges periodically, this may be due to thermal expansion in a closed water supply system. Contact the water supplier or local plumbing inspector on how to correct situation. **DO NOT PLUG THE TEMPERATURE AND PRESSURE RELIEF VALVE.**

GAS CONNECTIONS

The minimum gas supply pressure for input adjustment is 5.0" W.C. for natural gas (11.0" W.C. for propane).

THE HEATER IS NOT INTENDED FOR OPERATION AT HIGHER THAN 14" WATER COLUMN SUPPLY PRESSURE. EXPOSURE TO HIGHER GAS SUPPLY PRESSURE MAY CAUSE DAMAGE TO THE CONTROL WHICH COULD RESULT IN FIRE OR EXPLOSION. If overpressure has occurred such as through improper testing of gas lines or emergency malfunction of the supply system, the control must be checked for safe operation. Make sure that the outside vents on the supply regulators and the safety vent valves are protected against blockage. These are parts of the gas supply system not the heater. Vent blockage may occur during ice storms.

IT IS IMPORTANT TO GUARD AGAINST CONTROL FOULING FROM CONTAMINANTS IN THE GAS WAYS. SUCH FOULING MAY CAUSE IMPROPER OPERATION, FIRE OR EXPLOSION.

All piping must comply with local codes and ordinances or with the National Fuel Gas Code (ANSI Z223.1 NFPA-54) whichever applies.

WARNING
VENT HOOD(S) MAY BE
EXTREMELY HOT
DURING OPERATION.

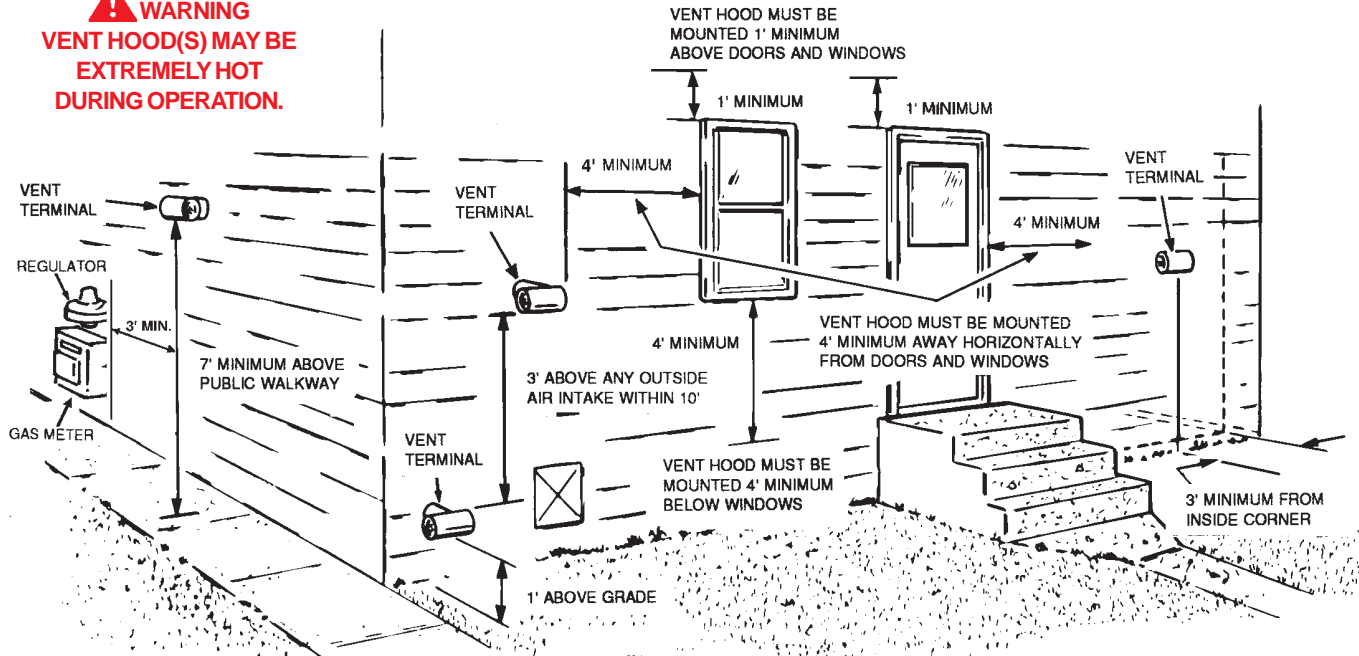

FIGURE 3

REFER TO FIGURE 1 FOR CONNECTION DETAILS. BEFORE ATTACHING THE GAS LINE BE SURE THAT ALL GAS PIPE IS CLEAN ON THE INSIDE.

TO TRAP ANY DIRT OR FOREIGN MATERIAL IN THE GAS SUPPLY LINE, A DIRT LEG (SOMETIMES CALLED DRIP LEG) MUST BE INCORPORATED IN THE PIPING, FIGURE 1. The dirt leg must be readily accessible. Install in accordance with recommendations of serving gas supplier. Refer to the latest edition of ANSI Z223.1.

To prevent damage, care must be taken not to apply too much torque when attaching gas supply pipe to thermostat gas inlet. The thermostat inlet has a pad for use with a backup wrench.

Apply joint compounds (pipe dope) sparingly and only to the male threads of pipe joints. Do not apply compound to the first two threads. Use compounds resistant to the action of liquefied petroleum gases. Do not use teflon tape on thermostat fittings.

CONNECTION OF GAS PIPE

1. When connecting gas pipe to unit, apply wrench to flange only. Note: Do not use wrench on gas valve or gas valve bracket.
2. **PERFORM THE GAS LEAK TEST ANY TIME WORK IS DONE ON A GAS SYSTEM TO AVOID THE POSSIBILITY OF FIRE OR EXPLOSION WITH PROPERTY DAMAGE, PERSONAL INJURY, OR LOSS OF LIFE.**

The Gas Leak Test is performed as follows: Paint pipe connections upstream of gas control with a rich soap and water solution to test for leaks before operating main burner. Bubbles indicate gas leak. To stop leak, tighten pipe connections. After piping connections are checked, turn on main burner. (See Lighting and Operating Installations in this manual or on water heater.) With main burner in operation, paint pipe joints (including flanges), pilot gas tubing connections and control inlet and outlet with rich soap and water solution. Bubbles indicate gas leak. To stop leak,

tighten flange screws, joints and pipe connections. Replace part if leak can't be stopped.

DISCONNECT THE APPLIANCE AND ITS INDIVIDUAL SHUT OFF VALVE FROM THE GAS SUPPLY PIPING SYSTEM DURING ANY SUPPLY PRESSURE TESTING EXCEEDING 1/2 PSI (3.5 kPa). GAS SUPPLY LINE MUST BE CAPPED WHEN DISCONNECTED FROM THE HEATER. FOR TEST PRESSURES AT 1/2 PSI (3.5 kPa) OR LESS, THE APPLIANCE NEED NOT BE DISCONNECTED, BUT MUST BE ISOLATED FROM THE SUPPLY PRESSURE TEST BY CLOSING THE MAIN MANUAL GAS VALVE.



BEFORE PLACING THE HEATER IN OPERATION, CHECK FOR GAS LEAKAGE. USE SOAP AND WATER SOLUTION OR OTHER MATERIAL ACCEPTABLE FOR THIS PURPOSE. DO NOT USE MATCHES, CANDLES, FLAME OR OTHER SOURCES OF IGNITION TO LOCATE GAS LEAKS.

RELIEF VALVE

A NEW TEMPERATURE AND PRESSURE RELIEF VALVE COMPLYING WITH THE STANDARD FOR RELIEF VALVES AND AUTOMATIC GAS SHUT OFF DEVICES FOR HOT WATER SUPPLY SYSTEMS, ANSI Z21.22 (LATEST EDITION) MUST BE INSTALLED IN THE HEATER IN THE MARKED OPENING PROVIDED. THE VALVE MUST BE OF A SIZE (INPUT RATING) THAT WILL BE ADEQUATE FOR YOUR SIZE HEATER.

Check the metal tag on the relief valve and compare it to the heater's rating plate. The pressure rating of relief valve must not exceed the working pressure shown on the rating plate of the heater. In addition the hourly Btu rated temperature steam discharge capacity of the relief valve shall not be less than the input rating of the heater. **NO VALVE IS TO BE PLACED**

BETWEEN THE RELIEF VALVE AND TANK. DO NOT PLUG THE RELIEF VALVE.

The drain line connected to this valve must not contain a reducing coupling or other restriction and must terminate near a suitable drain to prevent water damage during valve operation. The discharge line shall be installed in a manner to allow complete drainage of both the valve and line. **DO NOT THREAD, PLUG OR CAP THE END OF THE DRAIN LINE.**

VENTING



NEVER OPERATE THE HEATER UNLESS IT IS VENTED TO THE OUTDOORS AND HAS ADEQUATE AIR SUPPLY TO AVOID RISKS OF IMPROPER OPERATION, FIRE, EXPLOSION OR ASPHYXIATION.

VENT PIPE TERMINATION

The first step is to determine where the vent pipe will terminate, see Figures 3, 8 and 9. The vent may terminate through the roof as shown in Figure 9 or through a sidewall as shown in Figure 8.

IMPORTANT

The vent system must terminate so that proper clearances are maintained as cited in local codes or the latest edition of the National Fuel Gas Code, ANSI Z223.1, 7.3.4e and 7.8a, b.

For your convenience instructions on proper installation through a sidewall are provide in Figure 3 and the numbered points below:

1. The exit terminals of a mechanical vent system shall be not less than 7 feet above grade when located adjacent to public walkways.
2. A venting system shall terminate at least 3 feet above any forced air inlet located within 10 feet.
3. The venting system shall terminate at least 4 feet below, 4 feet horizontally from or, 1 foot above any door, window or gravity air inlet into any building.
4. The manufacturer also recommends that the vent system termination not be installed closer than 3 feet from an inside corner of an L shaped structure and not be less than 1 foot above grade. The vent shall terminate a minimum of 12" above expected snowfall level to prevent blockage of vent termination.
5. The vent termination shall not be mounted directly above or within 3 feet horizontally from an oil tank vent or gas meter to avoid potential freeze-up from condensation.

Plan the vent system layout so that proper clearances are maintained from plumbing and wiring.

Vent pipes serving power vented appliances are classified by building codes as "vent connectors". Required clearances from combustible materials must be provided in accordance with information in this manual under LOCATION OF HEATER and INSTALLATION OF VENT SYSTEM, and with the National Fuel Gas Code and local codes.

PLANNING THE VENT SYSTEM

Plan the route of the vent system from the discharge of the blower to the planned location of the vent terminal.

1. Layout the total vent system to use a minimum of vent pipe and elbows. Take into consideration that an elbow will be necessary to make the first vent pipe connection to the power venter outlet, see Figure 6.
2. This water heater is capable of venting the flue gases the equivalent of thirty (30) feet of 3 inch pipe or eighty-five (85) feet of 4 inch pipe as listed in Table 1.

TABLE 1

Number of 90° Elbows	3" Maximum Pipe (Feet)	4" Maximum Pipe Feet
ONE (1)	25	80
TWO (2)	20	75
THREE (3)	15	70
FOUR (4)	10	65
FIVE (5)	---	60

Minimum of 7 equivalent feet (one {1} elbow and 2 feet) must be installed for 3" and 4" pipe.

NOTE: The equivalent feet of pipe listed above are exclusive of the "Tee" termination. That is, the termination "Tee", with installed screens, is assumed to be in the system and the remainder of the system must not exceed the thirty (30) equivalent feet of 3 inch pipe or eighty five (85) equivalent feet of 4 inch pipe.

3. The blower discharge adapter is made to accept only straight sections of 3" pipe. To start a minimum of 2 inches of 3" pipe must be attached to the blower discharge, see Figure 6.

If using 3 inch vent pipe:

A minimum of 2 inches, maximum of 4 feet of 3" pipe must be attached to the blower before the first 3-inch elbow. After the first elbow add the additional venting required for the installation. The total system cannot exceed 30 equivalent feet of venting, where each elbow is equal to 5 feet of straight pipe.

If using 4 inch vent pipe:

Two inches of 3" pipe must be attached to the blower discharge. A 4" x 3" reducer is added and then up to maximum 4 feet of 4 inch pipe added before the first elbow. An additional 4" x 3" reducer and (1) foot of 3" pipe must be added to the end of the vent system before terminating into the 3" tee. The total system cannot exceed 85 equivalent feet of 4" venting, where each elbow is equal to 5 feet of straight pipe.

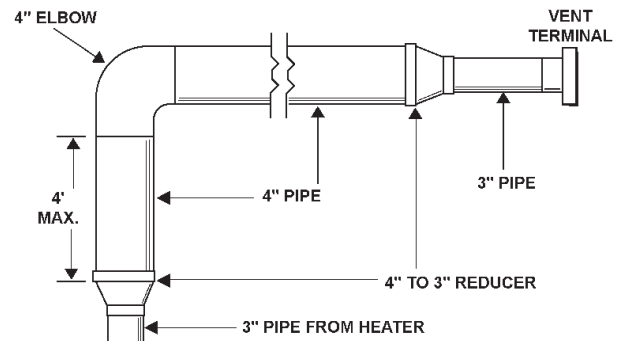

FIGURE 4

NOTE: This unit can be vented using only PVC (Class 160, ASTM D-2241; Schedule 40, ASTM D-1785; or Cellular Core Schedule 40 DWV, ASTM F-891), Schedule 40 CPVC/ASTM F-441), or ABS/ASTM D-2661) pipe. The fittings, other than the TERMINATION TEE should be equivalent to PVC-DWV fittings meeting ASTM D-2665 (Use CPVC fittings, ASTM F-438 for CPVC pipe and ABS fittings, ASTM D-2661/3311 for ABS pipe. If CPVC or ABS pipe and fittings are used, then the proper cement must be used for all joints, including joining the pipe to the Termination Tee (PVC Material). If local codes do not allow the use of the PVC termination when a material other than PVC is used for venting, than an equivalent fitting of that material may be substituted if the screens in the PVC terminal are removed and inserted into the new fitting.

PVC Materials should use ASTM D-2564 Grade Cement; CPVC Materials should use ASTM F-493 Grade Cement and ABS Materials should use ASTM D-2235 Grade Cement.

NOTE: A. For water heaters in locations with high ambient temperatures (above 100°F) and/or insufficient dilution air, it is recommended that CPVC or ABS pipe and fittings be used.
B. The SUPPLIED VENT TERMINAL must be used in all cases.

- The temperature of the flue gases leaving the blower is about 160°F after mixing the dilution air in the inlet adapter of the blower. Even with high concentrate of room air taken into the vent system for dilution air, there will be some installations where condensate will be formed in the horizontal runs of the vent system. This condensate will run into the condensate boot attached to the blower and out the fitting. The water heater is shipped with condensate hose that attaches to the fitting on the condensate boot. No other Tee or fitting is required. See Figures 8 and 9.

INSTALLATION OF VENT SYSTEM

Before beginning installation of piping system thoroughly read the section of this manual VENT PIPE PREPARATION.

If you are installing your system so that it vents through roof, please refer to following section titled INSTALLATION OF VERTICAL VENT SYSTEM.

VENT TERMINAL INSTALLATION, SIDEWALL

- Install the vent terminal by using the cover plate as a template to mark the hole for the vent pipe to pass through the wall. BEWARE OF CONCEALED WIRING AND PIPING INSIDE THE WALL.
- If the Vent Terminal is being installed on the outside of a finished wall, it may be easier to mark both the inside and outside wall. Align the holes by drilling a hole through the center of the template from the inside through to the outside. The template can now be positioned on the outside wall using the drilled hole as a centering point for the template.
- A) MASONRY SIDE WALLS
Chisel an opening approximately one half inch larger than the marked circle.

B) WOODEN SIDE WALLS

Drill a pilot hole approximately one quarter inch outside of the marked circle. This pilot hole is used as a starting point for a saws-all or sabre saw blade. Cut around the marked circle staying approximately one quarter inch outside of the line. (This will allow the vent to easily slide through the opening. The resulting gap will be covered up by the Vent Terminal cover plate.) Repeat this step on inside wall if necessary.

SEQUENCE OF INSTALLATIONS, FIGURE 5

Cut a length of 3" PVC pipe about 3.5 inches longer than the wall thickness at the opening. Glue the vent terminal "TEE" with screens to this section of pipe. Slide the wall plate over the pipe to stop against "TEE". Place a bead of caulking (not supplied) around the gap between the pipe and cover plate. Apply enough to fill some of the gap between the pipe and wall. Place some of the caulking on the back of the plate to hold it against the wall after installation. If the vent pipe is installed up to the wall, with a coupling on the end against the wall opening, the pipe with the vent terminal can be prepared for gluing before inserting through the wall. Slide the pipe through the wall and insert into the coupling on the other side of the wall, making sure that the vent terminal ends up pointed in the correct position, see Figure 5.

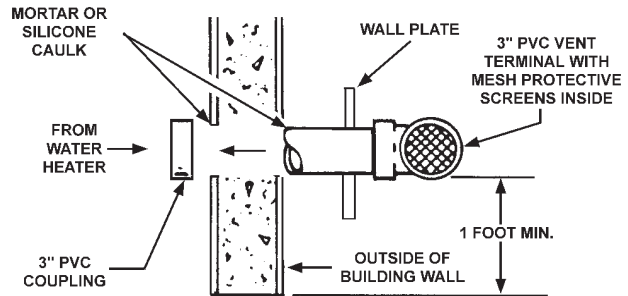

VENT TERMINATION - FIGURE 5

PREPARATION OF BLOWER ASSEMBLY

- Check to make sure that the wire harness is attached to the gas valve and blower control box.
- Make sure no material is still attached to the outside or inside of blower assembly.

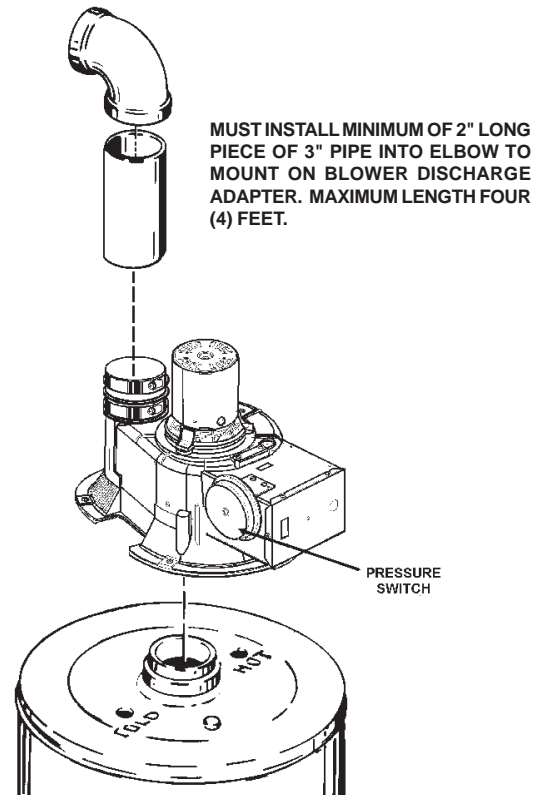

FIGURE 6

3. Make sure that plastic tubing is still attached to the pressure switch and fan housing. Also make sure that wiring connector from motor to control box is securely attached.
4. Do not plug in power cord until vent system is completely installed. The Power Vent operates on 120 Vac, therefore a grounded outlet must be within reach of the 6 foot flexible power cord supplied with the vent, see Figure 1. The power cord supplied may be used on unit only where local codes permit. If local codes do not permit use of flexible power supply cord:
 - A. Remove screws that hold cover plate on control box and remove plate.
 - B. Cut flexible power cord on inside of control box, as close to inside wall as possible.
 - C. If flexible cord and strain relief are removed, then opening in box must be covered plastic cap on the side of the control box.
 - D. Remove plastic cap on the right side of control box and

- E. install suitable conduit fitting in enclosure.
- E. Splice field wiring into existing wiring using code authorized method (wire nuts, etc).
- F. Be certain that neutral and line connections are not reversed when making these connections.
- G. Ground heater properly. This water heater must be grounded on accordance with the National Electric Code ANSI/NPA70 and/or local codes. These must be followed in all cases.

The water heater must be connected to a grounded metal, permanent wiring system; or an equipment grounding conductor must be run with the circuit conductors and connected to the equipment grounding terminal or lead on the water heater, see Figure 7.

- H. Replace cover plate and secure with two screws.
5. The blower discharge boot is made to accept only straight sections of 3" pipe. To start off with an elbow, a short section of the furnished pipe, a minimum of 2 inches, must be cut and glued into the end of the elbow that will mount on the discharge boot, see Figure 6.



LABEL ALL WIRES PRIOR TO DISCONNECTION WHEN SERVICING CONTROLS. WIRING ERRORS CAN CAUSE IMPROPER AND DANGEROUS OPERATION. VERIFY PROPER OPERATION AFTER SERVICING.

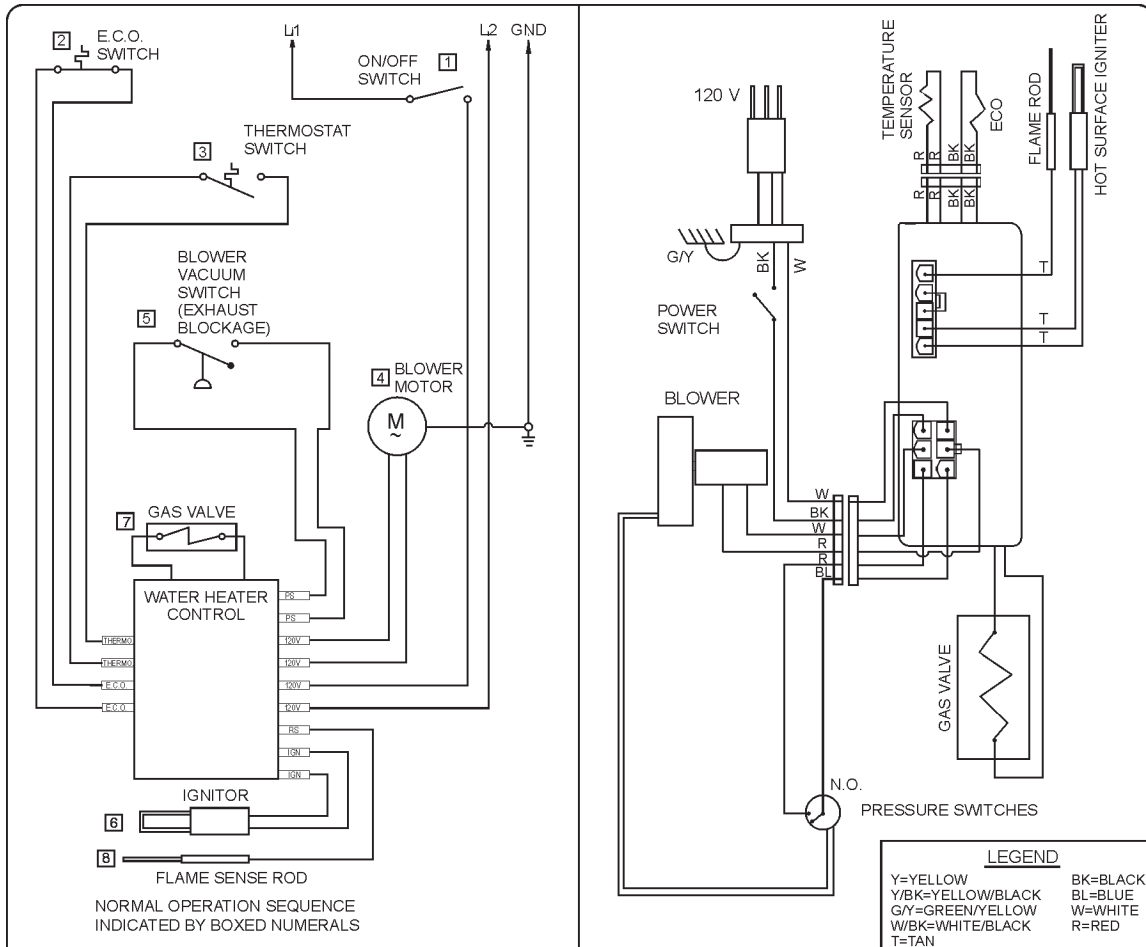

WARNING

DISCONNECT FROM ELECTRICAL SUPPLY BEFORE SERVICING UNIT.
REPLACE ALL DOORS AND PANELS BEFORE OPERATING HEATER.

IF ANY OF THE ORIGINAL WIRES SUPPLIED WITH THE APPLIANCE MUST BE REPLACED, IT MUST BE REPLACED WITH APPLIANCE WIRE MATERIAL WITH MINIMUM TEMPERATURE RATING OF 105°C AND A MINIMUM SIZE OF NO. 18 AWG.

POWER VENT WIRING SCHEMATIC - FIGURE 7

INSTALLATION OF VENT SYSTEM, SIDEWALL

With the route of the venting system and selection of materials completed, as discussed in section of this manual titled PLANNING THE VENT SYSTEM, the through the wall vent terminal in place and the first section of piping, up to first elbow, installed at the blower it is time to complete the installation of the venting system for the sidewall installation.

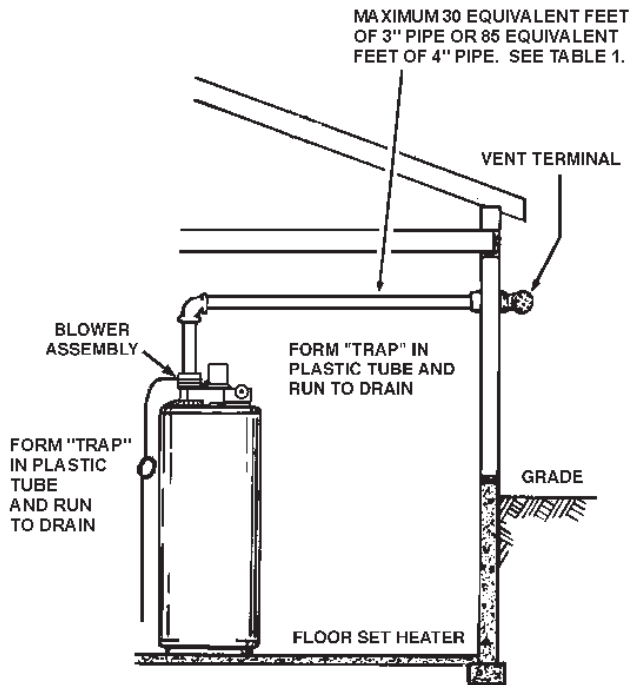

FIGURE 8

Before completing the installation of the venting system be sure to read the sections of this manual discussing the proper method of cutting and cementing PVC pipe and fittings: VENT PIPE PREPARATION.

It is recommended that the completion of the venting system start at the blower assembly and run to the coupling on the inside wall of the vent terminal, Figure 5.

The vent system piping should be supported every 5 feet of vertical run and every 3 feet of horizontal run. All piping and fittings must be joined by the proper procedures as described under: VENT PIPE PREPARATION.

INSTALLATION OF VERTICAL VENT SYSTEM

This unit is approved for venting through the roof with only the vent terminal that is included with the unit, see Figure 9. A proper flashing or "BOOT" should be used to seal the pipe where it exits the roof. The total vent system should not exceed the thirty (30) equivalent feet of 3 inch pipe or eighty five (85) equivalent feet of 4 inch pipe as listed in Table 1.

NOTE: The equivalent feet of pipe listed above are exclusive of the "TEE" termination with installed screens.

Provide support for all pipe protruding through the roof. All piping should be properly secured. The vent system piping should be supported every 5 feet of vertical run and every 3 feet of horizontal run. All piping and fittings must be joined by the proper procedures as described under: VENT PIPE PREPARATION.

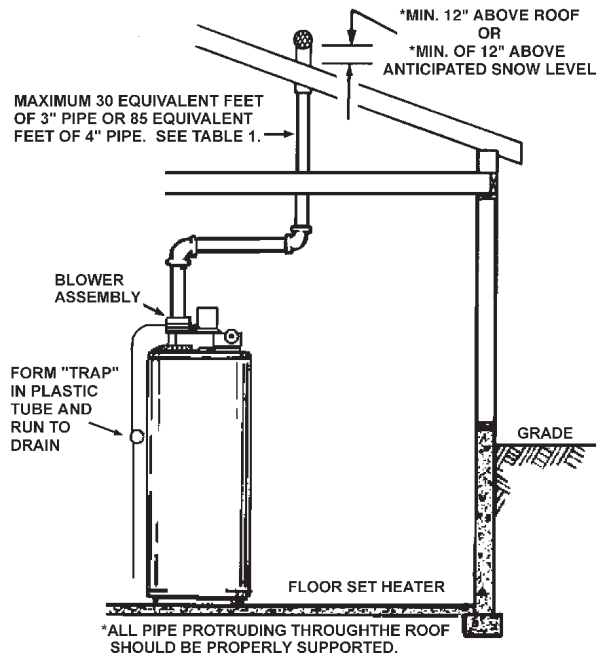

FIGURE 9

IMPORTANT

The vent system must terminate so that proper clearances are maintained as cited in local codes or the latest edition of the National Fuel Gas Code, ANSI Z223.1 and as listed below:

1. Vent Termination must extend a minimum of 12 inches above roof or 12 inches above the anticipated snow level to prevent blockage of the vent termination.
2. The venting system shall terminate at least four (4) feet from or one (1) foot above any gable, dormer or other roof structure with building interior access; i.e., vent, window, etc.
3. The venting system shall terminate three (3) feet above any forced air inlet located within ten feet.

VENT PIPE PREPARATION

1. INITIAL PREPARATION

- A. Make sure the solvent cement you are planning to use is designed for the specific application you are attempting.
- B. Know the physical and chemical characteristics and limitations of the PVC and CPVC piping materials that you are about to use.
- C. Know the reputation of your manufacturer and their products.
- D. Know your own qualifications or those of your contractor. The solvent welding technique of joining PVC and CPVC pipe is a specialized skill just as any other pipe fitting technique.
- E. Closely supervise the installation and inspect the finished job before start-up.
- F. Contact the manufacturer, supplier, or competent consulting agency if you have any questions about the application or installation of PVC and CPVC pipe.
- G. Take the time and effort to do a professional job. Shortcuts will only cause you problems and delays in start-up. By far, the majority of failures in PVC and CPVC systems are the result of shortcuts and/or improper joining techniques.

2. SELECTION OF MATERIALS

- Cutting Device - Saw or Pipe Cutter
- Deburring Tool, Knife, File, or Beveling Machine (2" and above)
- Brush - Pure Bristle
- Rag - Cotton (Not Synthetic)
- Primer and Cleaner
- Solvent Cement - PVC for PVC Components and CPVC for CPVC Components
- Containers - Metal or Glass to hold Primer and Cement. Select the type of PVC or CPVC materials to be used on the basis of their application with respect to chemical resistance, pressure rating, temperature characteristics, etc.
- Insertion Tool - Helpful for larger diameter pipe and fittings (6" and above).

PRIMER

It is recommended that Tetrahydrofuran (THF) be used to prepare the surfaces of pipe and fittings for solvent welding. Do not use water, rags, gasoline or any other substitutes for cleaning PVC or CPVC Surfaces. A chemical cleaner such as MEK may be used.

CEMENT

The cement should be a bodied cement of approximately 500 to 1600 centipoise viscosity containing 10-20% (by weight) virgin PVC material solvated with tetrahydrofuran (THF). Small quantities of dimethyl formamide (DMF) may be included to act as a retarding agent to extend curing time. Select the proper cement; Schedule 40 cement should be used for Schedule 40 pipe. Never use all-purpose cements, commercial glues and adhesives or ABS cement to join PVC or CPVC pipe and fittings.

SAFETY PRECAUTION: PRIMERS AND CEMENTS ARE EXTREMELY FLAMMABLE, AND MUST NOT BE STORED OR USED NEAR HEAT OR OPEN FLAME. ALSO, USE ONLY IN A WELL-VENTILATED AREA.

APPLICATORS

Select a suitable pure bristle type paint brush. Use a proper width brush or roller to apply the primer and cement (see chart below). Speedy application of cement is important due to its fast drying characteristics. **IMPORTANT NOTE:** A dauber type applicator should only be used on pipe sizes 2" and below. For larger diameter pipe, a brush or roller must be used.

3. MAKING THE JOINT

A. Cutting

Pipe must be squarely cut to allow for the proper interfacing of the pipe end and the fitting socket. This can be accomplished with a miter box saw or wheel type cutter. Wheel type cutters are not generally recommended for larger diameters since they tend to flare the corner of the pipe end. If this type of cutter is used, the flare on the end must be completely removed.

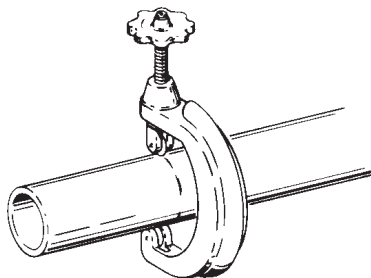

STEP A

NOTE: Power saws should be specifically designed to cut plastic pipe.

B. Deburring

Use a knife, plastic pipe deburring tool, or file to remove burrs from the end of small diameter pipe. Be sure to remove all burrs from around the inside as well as the outside of the pipe. A slight chamfer (bevel) of about 10°-15° should be added to the end to permit easier insertion of the pipe into the end of the fitting. Failure to chamfer the edge of the pipe may remove cement from the fitting socket, causing the joint to leak.

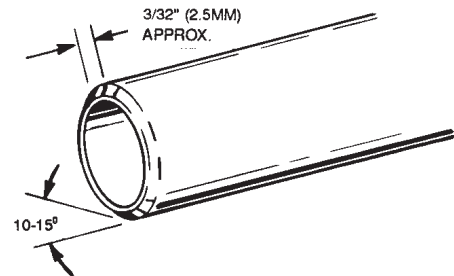

STEP B

C. Test dry fit of the joint

Tapered fitting sockets are designed so that an interference fit should occur when the pipe is inserted about 1/3 to 2/3 of the way into the socket. Occasionally, when pipe fitting dimensions are at the tolerance extremes, it will be possible to fully insert dry pipe to the bottom of the fitting socket. When this happens, a sufficient quantity of cement must be applied to the joint to fill the gap between the pipe and fitting. The gap must be filled to obtain a strong, leak-free joint.

D. Inspection, cleaning, priming

Visually inspect the inside of the pipe and fitting sockets and remove all dirt, grease or moisture with a clean dry rag. If wiping fails to clean the surfaces, a chemical cleaner must be used. Check for possible damage such as splits or cracks and replace if necessary.

Depth-of-entry mark

Marking the depth of entry is a way to check if the pipe has reached the bottom of the fitting socket in step F. Measure the fitting depth and mark this distance on the pipe O.D. You may want to add several inches to the distance and make a second mark as the primer and cement will most likely destroy your first one.

Apply primer to the surface of the pipe and fitting socket with a natural bristle brush (see chart). This process softens and prepares the PVC or CPVC for the solvent cementing step. Move quickly and without hesitation to the cementing procedure while the surfaces are still wet with primer.

E. Application of solvent cement

- Apply the solvent cement evenly and quickly around the outside of the pipe at a width a little greater than the depth of the fitting socket.
- Apply a light coat of cement evenly around the inside of the fitting socket. Avoid puddling.
- Apply a second coat of cement to the pipe end.

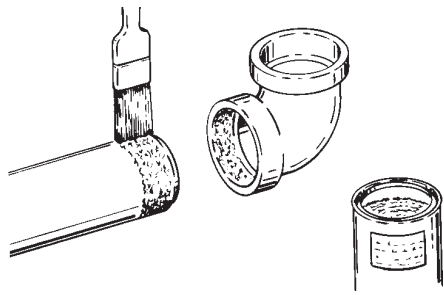

STEP E

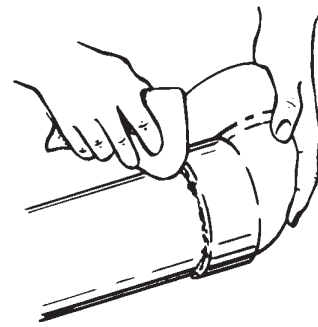

STEP G

NOTE: Cans of cement and primer should be closed at all times when not in use to prevent evaporation of chemicals and hardening of cement. They are also very flammable and should be kept away from heat or flame.

F. Joint assembly

Working quickly, insert the pipe into the fitting socket bottom and give the pipe or fitting a 1/4" turn to evenly distribute the cement. Do not continue to rotate the pipe after it has hit the bottom of the fitting socket. A good joint will have sufficient cement to make a bead all the way around the outside of the fitting hub. The fitting will have a tendency to slide back while the cement is still wet so hold the joint together for about 15 seconds.

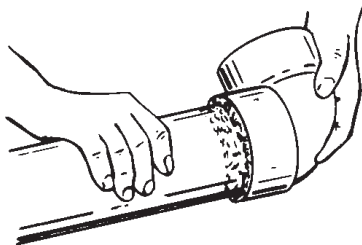

STEP F

G. Cleanup and joint movement

Remove all excess cement from around the pipe and fitting with a dry cotton rag. This must be done while the cement is still soft.

The joint should not be disturbed immediately after the cementing procedure, and sufficient time should be allowed for proper curing of the joint. Exact drying time is difficult to predict because it depends on variables such as temperature, humidity and cement integrity. For more specific information, you should contact your solvent cement manufacturer.



OPERATION

! WARNING

DO NOT ATTEMPT TO OPERATE WATER HEATER WITH COLD WATER INLET VALVE CLOSED.

NEVER OPERATE THE HEATER WITHOUT FIRST BEING CERTAIN IT IS FILLED WITH WATER AND A TEMPERATURE AND PRESSURE RELIEF VALVE IS INSTALLED IN THE RELIEF VALVE OPENING OF THE HEATER.

TO OPERATE THE HEATER

1. Close the heater drain valve by turning handle clockwise ↻
2. Open a nearby hot water faucet to permit the air in the system to escape.
3. Fully open the cold water inlet pipe valve allowing the heater and piping to be filled.
4. Close the hot water faucet as water starts to flow.
5. The heater is ready to be operated.

! CAUTION

THE "ON/OFF" SWITCH ON THE CONTROL BOX SHOULD NOT BE TURNED TO THE "OFF" POSITION UNLESS THE UNIT IS BEING SERVICED.

FOR YOUR SAFETY READ BEFORE LIGHTING



WARNING: If you do not follow these instructions exactly, a fire or explosion may result causing property damage, personal injury or loss of life.



BEFORE OPERATING: ENTIRE SYSTEM MUST BE FILLED WITH WATER AND AIR PURGED FROM ALL LINES.

- A. This appliance does not have a pilot. It is equipped with an ignition device which automatically lights the burner. **Do NOT try to light the pilot by hand.**
- B. **BEFORE OPERATING** smell all around the appliance area for gas. Be sure to smell next to the floor because some gas is heavier than air and will settle on the floor.
- WHAT TO DO IF YOU SMELL GAS:**
- Do not try to light any appliance.
 - Do not touch any electric switch; do not use any phone in your building.
 - Immediately call your gas supplier from a neighbor's phone. Follow the gas supplier's instructions.
- If you cannot reach your gas supplier, call the fire department.
- C. Use only your hand to push in the control buttons. Never use tools. If the control buttons will not push in, don't try to repair them, call a qualified service technician. Force or attempted repair may result in a fire or explosion.
- D. Do not use this appliance if any part has been under water. Immediately call a qualified service technician to inspect the appliance and to replace any part of the control system and any gas control which has been under water.

OPERATING INSTRUCTIONS

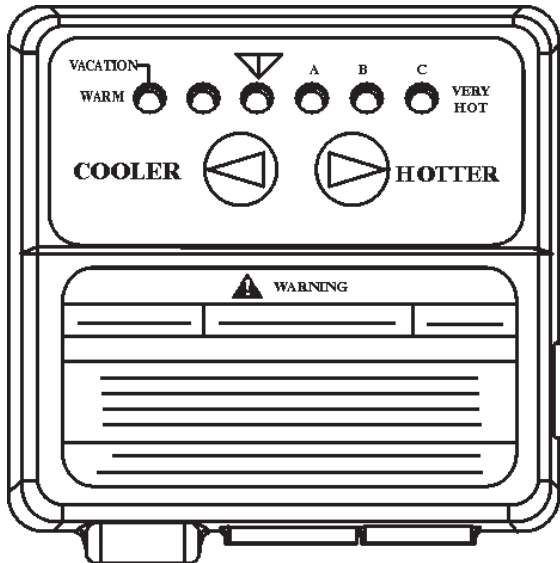

1.  STOP! Read the safety information above on this label.
2. Set the thermostat to the lowest setting.
3. Turn the "ON/OFF" switch on the blower control box to the "OFF" position.

4. This appliance is equipped with a device which automatically lights the burner.

DO NOT TRY TO LIGHT THE BURNER BY HAND.

5. Wait five (5) minutes to  clear out any gas. If you then smell gas, STOP! Follow "B" in the safety information above on this label. If you don't smell gas, go to the next step.
6. Turn on all electrical power to the appliance.
7. Set thermostat to desired setting.
8. If the appliance will not operate, follow the instructions "TO TURN OFF GAS TO APPLIANCE" and call your technician or gas supplier.
9. WATER TEMPERATURE ADJUSTMENT

▼ is approximately 120°F.



CAUTION: Hotter water increases the risk of scald injury. Consult the instruction manual before changing temperature.



WARNING: TURN OFF ALL ELECTRIC POWER BEFORE SERVICING

TO TURN OFF GAS TO APPLIANCE

- A. Set thermostat to the lowest setting.
- B. Turn off all the electric power to the appliance if service is to be performed.

TEMPERATURE REGULATION

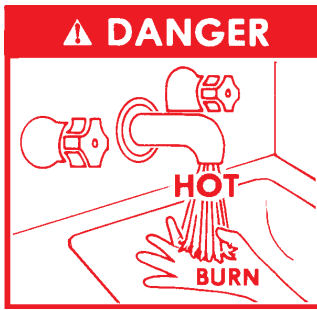

CAUTION

THIS WATER HEATER IS EQUIPPED WITH AN ADJUSTABLE THERMOSTAT TO CONTROL WATER TEMPERATURE. HOT WATER TEMPERATURES REQUIRED FOR AUTOMATIC DISHWASHER AND LAUNDRY USE CAN CAUSE PAINFUL SCALDING WITH POSSIBLE SERIOUS AND PERMANENT INJURY. THE TEMPERATURE AT WHICH INJURY OCCURS VARIES WITH THE PERSON'S AGE AND THE TIME OF EXPOSURE. THE SLOWER RESPONSE TIME OF CHILDREN, AGED OR DISABLED PERSONS INCREASES THE HAZARDS TO THEM. NEVER ALLOW SMALL CHILDREN TO USE A HOT WATER TAP OR TO DRAW THEIR OWN BATH WATER. NEVER LEAVE A CHILD OR DISABLED PERSON UNATTENDED IN A BATHTUB OR SHOWER.

THE WATER HEATER SHOULD BE LOCATED IN AN AREA WHERE THE GENERAL PUBLIC DOES NOT HAVE ACCESS. IF A SUITABLE AREA IS NOT AVAILABLE, A COVER SHOULD BE INSTALLED OVER THE THERMOSTAT TO PREVENT TAMPERING. Suitable covers are available through A.O. Smith Water Products Company, 5621 W. 115th Street, Alsip, IL 60803.

It is recommended that lower water temperatures be used to avoid the risk of scalding. It is further recommended, in all cases, that the water temperature be set for the lowest temperature which satisfies your hot water needs. This will also provide the most energy efficient operation of the water heater. The water temperature adjustment was factory set at the lowest temperature. Pressing the "COOLER" button decreases temperature and pressing the "HOTTER" button increases the temperature.

SETTING THE WATER HEATER TEMPERATURE AT 120°F (APPROX. "▼" MARK ON TEMPERATURE SETTING OF GAS VALVE) WILL REDUCE THE RISK OF SCALDS. Some states require settings at specific lower temperatures.

Figure 10 shows the approximate water temperatures produced at various thermostat settings. Short repeated heating cycles caused by small hot water uses can cause temperatures at the point of use to exceed the thermostat setting by up to 30°F. If you experience this type of use you should consider using lower temperature settings to reduce scald hazards.

Valves for reducing the point-of-use temperature by mixing cold and hot water are available, see Figure 2. Also available are inexpensive devices that attach to faucets to limit hot water temperatures. Contact a licensed plumber or the local plumbing authority.

To avoid any unintentional changes in water temperature settings, the control has a tamper resistant feature for changing the temperature setting. To change the temperature setting follow these instructions:

1. "Wake Up" the temperature indicators by holding down both the "COOLER" and "HOTTER" temperature adjustment buttons at the same time for one second, see Figure 10. One or two of the temperature indicators will light up. These indicators will only remain on for 30 seconds if no further buttons are pressed. After 30 seconds the control will go back to "Sleep" mode.

2. Release both of the temperature adjustment buttons.
 - A. To decrease the temperature press and release the "COOLER" button until desired setting is reached.
 - B. To increase the temperature press and release the "HOTTER" button until the desired setting is reached.

NOTE: Holding down the button will not continue to lower or raise the temperature setting. The button must be pressed and released for each temperature change desired.

SHOULD OVERHEATING OCCUR OR THE GAS SUPPLY FAIL TO SHUT OFF, TURN OFF THE MAIN MANUAL GAS SHUTOFF VALVE TO THE APPLIANCE. SEE FIGURE 1 (G).

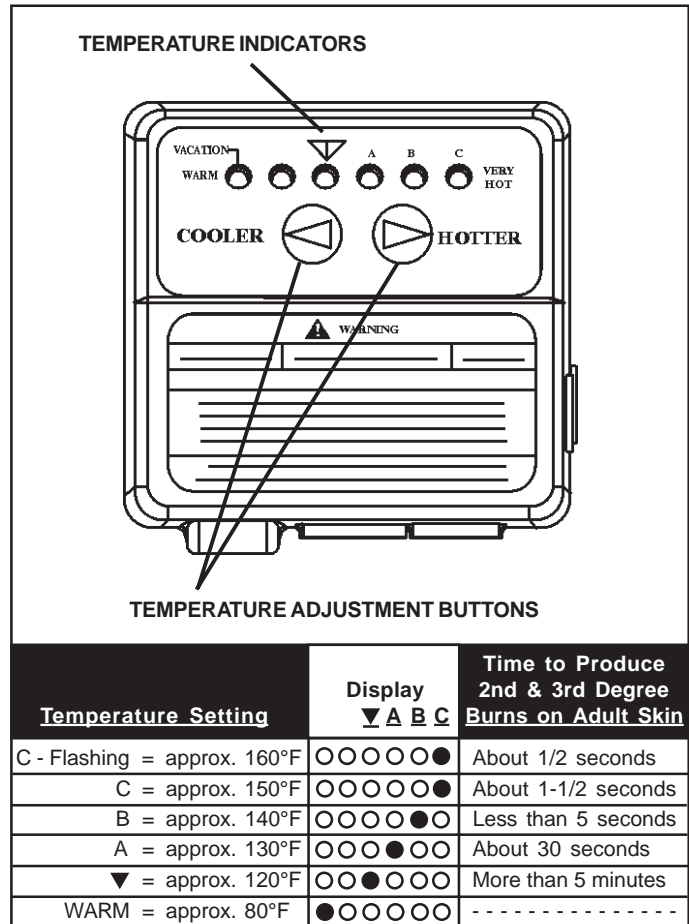

FIGURE 10



MAINTENANCE

CAUTION

DISCONNECT FROM ELECTRICAL SUPPLY BEFORE SERVICING UNIT. FOR YOUR SAFETY, WATER HEATER

SERVICE SHOULD BE PERFORMED ONLY BY A QUALIFIED SERVICE TECHNICIAN. READ THE GENERAL SAFETY INFORMATION SECTION FIRST.

USERS OF THIS APPLIANCE SHOULD BE AWARE THAT GAS COMPONENTS WEAR OUT OVER A PERIOD OF TIME. THE GAS CARRYING COMPONENTS OF THIS APPLIANCE SHOULD BE INSPECTED FOR PROPER OPERATION PERIODICALLY BY A QUALIFIED SERVICE TECHNICIAN.

MAIN BURNER

Check main burner every 12 months for proper flame characteristics. This is done by removing door(s) on heater, see Figure 1. The main burner should provide complete combustion of gas; ignite rapidly; give reasonably quiet operation; cause no excessive flame lifting from burner ports. Make sure that the flow of combustion and ventilation air is not blocked.

If proper flame characteristics are not evident, check for accumulation of lint or other foreign material that restricts or blocks the air openings in the heater or burner. Also check AIR REQUIREMENTS.

! WARNING

SOOT BUILD-UP INDICATES A PROBLEM THAT REQUIRES CORRECTION BEFORE FURTHER USE. Consult with a qualified service technician.

Should the main burner or burner air openings require cleaning, turn the control switch to "OFF" position and allow the burner to cool. Remove the burner and clean with a soft brush. Clean main burner orifice with a suitable soft material.

HIGH TEMPERATURE LIMIT SWITCH

The thermostat has a single use built-in limit switch which will shut off gas to burner in case of excessive water temperatures. The thermostat must be replaced if the limit switch opens.

VENTING SYSTEM

HAVE VENTING SYSTEM CHECKED EVERY SIX MONTHS FOR OBSTRUCTIONS AND/OR DETERIORATION IN VENT PIPING.

- A. Insofar as is practical, close all doors, windows and air inlets to the building. Turn on all exhaust fans (range hood, bathroom exhaust, etc.) so they will operate at their maximum speed. Close fireplace dampers.
- B. Turn water temperature adjusting knob to full, counterclockwise and open water faucet if necessary to keep burner in operation.
- C. "CHECKING THE DRAFT." Operate the water heater for several minutes and check to see if it is venting properly by passing a lit match or paper near the opening of the Air Mixing Box, see Figure 11. If the draft is proper, the match flame will be drawn into the Air Mixing Box. If not, the combustion products will tend to extinguish the flame. If an improper draft exists, do not operate the water heater until proper adjustments or repairs are made to provide adequate draft through the gas vent.
- D. Next, turn on all other fuel burning appliances within the same room so they will operate at their full input.

Repeat step C above.

POWER VENTER MAINTENANCE

The FPSH-75 must be inspected quarterly. Points of inspection are:

1. MOTOR - Motor must rotate freely. This is a sealed motor and no oiling is required.
2. WHEEL - Wheel must be clean of soot, ash or any other coating which inhibits either rotation or air flow. Remove all foreign material from vent system before operating.
3. AIR SUPPLY BOX - Every month check operation and make sure nothing is blocking dilution air entrance.
4. The pressure switch part inside the power venter must be open and free from deposits of soot, carbon, etc.

For safety and satisfactory operation it is recommended that the heater be checked once a year by a competent service person.

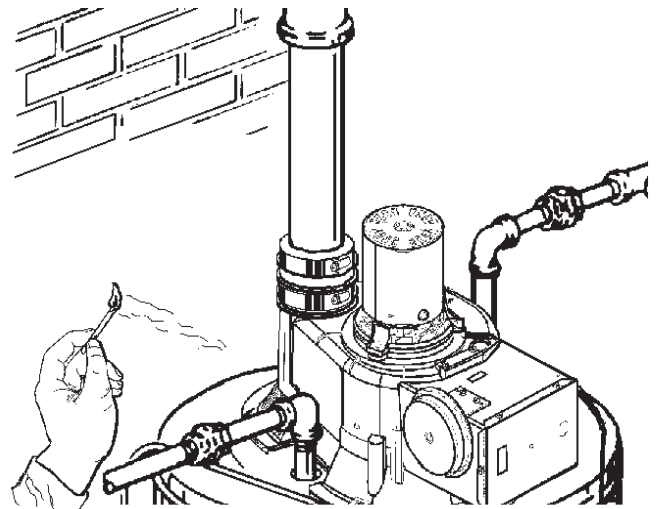

FIGURE 11

T & P VALVE

At least once a year, the temperature and pressure relief valve must be checked to ensure that it is in operating condition. Lift the lever at the top of the valve several times until the valve seats properly and operates freely.

! WARNING

THE WATER PASSING OUT OF THE VALVE DURING THIS CHECKING OPERATION MAY BE EXTREMELY HOT. AVOID CONTACT AND DISCHARGE SAFELY TO PREVENT WATER DAMAGE.

DRAINING

Periodically open the drain valve and allow the water to run until it flows clean. This will help prevent sediment build-up in the tank.

It is normal for lime and scale deposits to form within the tank and on the heat exchanger surfaces. Such deposits will not be removed by periodic draining. It is necessary to chemically delime the affected parts in water areas where such deposits are encountered. Contact your dealer or plumber for deliming information.

If the heater is to be shut off and exposed to freezing temperatures, it must be drained. Water, if left in the tank and allowed to freeze, will damage the heater.

- Turn off the gas and cold water inlet valve to the heater.
- Open a nearby hot water faucet and the heater drain valve.
- BE CAREFUL TO GRASP THE DRAIN VALVE HANDLE SO THAT THE HAND IS NOT EXPOSED TO HOT WATER. IF DESIRED, A HOSE MAY BE CONNECTED TO THE DRAIN VALVE TO CARRY THE WATER AWAY.

 **WARNING: The water CAN BE HOT.**

The drain valve must be left open during the shutdown period.

- To restart heater, refer to the instructions under OPERATION.

CONDENSATION

Water vapor can condense on the cooler surfaces of the tank forming droplets, these drip into the fire or run out on the floor. This is common at the time of startup after installation, during periods of time when incoming water is very cold, or the heater may be undersized for the requirements.

Droplets from the bottom of the flue may be due to corrosive combustion products or improper vent. Check with your dealer for more information.

CATHODIC PROTECTION-ANODE

The anode rod within the tank is designed to be slowly consumed cathodically, minimizing corrosion in the glass lined tank. The anode rod is used to protect the tank from corrosion. Most hot water tanks are equipped with an anode rod. The submerged rod sacrifices itself to protect the tank. Instead of corroding the tank, water ions attack and eat away the anode rod. This does not effect the water's taste or color. The rod must be maintained to keep the tank in operating condition. Failure to inspect and/or replace the anode rod will result in voiding the warranty. Anode deterioration depends on water conductivity, not necessarily water condition. It may be necessary to have the anode rod inspected a few times during the first year to see what effect the water has had. A corroded or pitted rod, in the first year, indicates high water conductivity and should be checked and/or replaced more often than an anode rod that appears to be fairly clean. Inspection should be conducted by a qualified technician.

A hydrogen sulfide (rotten egg) odor may result if water contains high sulfate and/or minerals. Chlorinating the water supply should minimize the problem. (See EXTENDED NON-USE PERIODS).

NOTE: Anode must remain installed (except for inspection) to avoid shortening tank life. See LIMITED WARRANTY. Replace as necessary.

SERVICE AND REPAIR

The A.O. Smith water heater requires no special care other than the normal maintenance as noted above. If you are having a problem with your water heater, before calling for service please refer to the following TROUBLESHOOTING sections. If service becomes necessary, contact your dealer, installer or an authorized service agent. Do not attempt to repair the water

heater yourself. Any work performed by unauthorized personnel may void the warranty.

If you are having a problem with your A.O. Smith water heater and are not pleased with the service you received:

- First, please contact your dealer or the A.O. Smith authorized service agent in your area and explain to them why you are not satisfied. This will usually correct the problem.
- If after working with your dealer or service agent the problem has not been resolved to your satisfaction, please let us know by either writing to us at:

A.O. Smith Water Products Company
Service Department
500 Lindahl Parkway
Ashland City, TN 37015-1299

or, going to our website at: www.hotwater.com
Please click on: "Contact us",
then click on: "Service"
and leave us a message.

Please be sure to provide the following information when writing or e-mailing:

- Model Number
- Serial Number
- Date of Original Purchase
- Date Problem Originated
- Explanation of Problem

Also, please be sure to include a daytime telephone number.

TROUBLE SHOOTING

Water heater may exhibit problems that are unrelated to a malfunction of the water heater itself. The following information and tables may serve to answer your question about a problem that you are having without having to call a service agent.

For your safety, water heater service should be performed only by a qualified service technician. Read the GENERAL SAFETY INFORMATION section first.

WATER HEATING IGNITION SEQUENCE

(Make sure gas and electric power are connected properly)

- 1) The ignition control module is powered and monitors the system, waiting for a call for heat from the thermostat.
- 2) The thermostat calls for heat by reading a resistance value within a given range directly proportional to water temperature.
- 3) The Control Module:
 - a) Check the pressure switches for an open circuit.
 - b) Energizes the blower.
 - c) Checks the pressure switches for a closed circuit to prove draft.
 - d) Sends line voltage to the hot surface igniter with a 20-second warm up period.
 - e) Opens the gas valve and check the sensing rod for flame.
- 4) The burner heats the water to the desired thermostat setting.
 - a) The resistance in the thermostat rises to the value selected by the temperature control knob.
 - b) The control module closes the gas valve and 5 seconds later, removes power from the blower.
- 5) Cycle is completed.

! WARNING: DO NOT BY-PASS ANY CONTROLS TO MAKE HEATER OPERATE. OPERATE ONLY AS WIRED FROM FACTORY.

TROUBLESHOOTING

For your safety, water heater service should be performed only by a qualified service technician.
Read the GENERAL SAFETY INFORMATION section first.

PROBLEM	POSSIBLE MALFUNCTION	SERVICE TO BE PERFORMED
NOT ENOUGH OR NO HOT WATER	1) Blower will not run	
	A) "ON/OFF" control switch turned off	Turn switch to the "ON" position.
	B) Blower unplugged	Plug blower back into 115 vac. outlet.
	C) No power at outlet	Repair service to outlet.
	D) "ON/OFF" switch defective	Replace switch.
	E) Control harness defective	Replace control harness.
	F) Blower motor defective	Replace blower and motor.
	2) Blower running, burner not on	Replace switch.
	A) Fan not running fast enough to close air switch contacts	Check for low voltage, less than 102 vac., have service checked and repaired. If voltage is above 102 vac., make sure there is not more than 30 Equivalent feet of 3 inch pipe or 85 equivalent feet of 4 inch pipe installed or vent terminal blockage. If at least 102 vac., less than 30 equivalent feet of 3 inch pipe or 85 equivalent feet of 4 inch pipe and not terminal blockage, replace blower.
	B) Air pressure switch defective	Replace switch.
	C) Gas valve defective	Replace gas valve.
	D) Control harness defective	Replace harness.
	E) Igniter defective	Replace igniter.
	F) Unit has completed three trials to light and failed	Reset cycle by turning switch off and then back on. If unit does not light in three trials, call an authorized A.O. Smith service representative.
	G) Discharge air limit tripped	Verify dilution air openings are free of obstructions. Make sure there is no more than 30 equivalent feet of 3 inch pipe or 85 equivalent feet of 4 inch pipe. Check for low voltage, less than 102 vac., have service checked and repaired. Make sure vent terminal is not blocked.
	3) Thermostat problems	
	A) Thermostat set too low	Turn temperature control higher.
	B) Thermostat or ECO defective	Replace thermostat.
	C) High limit control circuit open	Replace.
	4) Others	
A) Heater undersized	Reduce hot water use.	
B) Low gas pressure	Contact an authorized A.O. Smith service representative.	
C) Incoming water is unusually cold	Allow more time for heater to re-heat.	
D) Leaking hot water pipes or fixtures	Have plumber check and repair leaks.	
E) Polarity reversed	Correct wiring	
F) Heater not grounded	Correct	
VENT PIPE TOO HOT (ABOVE 170° F)	A) Blower does not run when heater fired	Take unit out of service immediately, call an authorized A.O. Smith service representative.
	B) Not enough dilution air to mix with flue gases in "Tee"	Proper air circulation must be provided for combustion and dilution of flue temp. Refer to "INSTALLATION" section.
	C) Air in room too hot for mixing with flue gases	Room air to be used for dilution with combustion products in flue should be less than 90°F.
	D) Wrong burner orifice	Install correct orifice.
YELLOW FLAME	A) Dirt in burner ports	Turn off heater and gas, clean burner head.
	B) Combustion air path restricted	Clear area around heater and check under heater, remove any debris under heater and in openings in bottom cover.
	C) Not enough room air for proper combustion	Refer to installation manual - Confined and Unconfined Space statements on page 4 and 5 for required openings.
CONDENSATION	A) Water on the floor under heater	See "CONDENSATION."
WATER LEAKS	Improperly sealed, hot or cold supply connections, relief valve, drain valve or thermostat threads	Turn off heater & water, repair unit.
	Leakage from other appliances or water lines	Inspect other appliances near water heater.
	Condensation of flue products	Refer to "CONDENSATION."
LEAKING T&P VALVE	Thermal expansion in closed water system Improperly seated valve	Install thermal expansion tank (DO NOT plug T&P valve). Check relief valve for proper operation (DO NOT plug T&P valve).
HOT WATER ODORS OR COLOR (Refer to CATHODIC PROTECTION)	High sulfate or mineral content in water supply or iron or sulfate reducing bacteria in water supply	Drain and flush heater thoroughly, chlorinate, refill and flush again then chlorinate water supply.
HEATER LIGHT GOES OUT IN 4-5 SECONDS	Outlet polarity is reversed	Test polarity and correct.

TROUBLE SHOOTING

Water heater may exhibit problems that are unrelated to a malfunction of the water heater itself. The following information and tables may serve to answer your question about a problem that you are having without having to call a service agent.

⚠ WARNING: DO NOT BY-PASS ANY CONTROLS TO MAKE HEATER OPERATE. OPERATE ONLY AS WIRED FROM FACTORY.

TROUBLE SHOOTING GUIDE

Please check guidelines below. For your safety, water heater service should be performed only by a qualified service technician. Read the GENERAL SAFETY INFORMATION section first.

LED STATUS	PROBLEM	SOLUTION
	An open earth ground circuit to the ignition system.	<ol style="list-style-type: none"> 1. Check that the earth ground connection is properly connected. 2. Check that the ground conductor on the water heater is properly connected.
	Wiring error or a high resistance to earth ground.	<ol style="list-style-type: none"> 1. Check for proper connection of line neutral and hot wires. 2. Check that the water heater is securely connected to earth ground.
	Pressure switch remained closed longer than 5 seconds after the call for heat began.	<ol style="list-style-type: none"> 1. Pressure switch wiring is incorrect. 2. Replace pressure switch.
	Pressure switch remained open longer than 5 seconds after the combustion blower was energized.	<ol style="list-style-type: none"> 1. Pressure switch wiring is incorrect. 2. Pressure switch tubing not connected correctly. 3. Air intake or exhaust obstructed.
	Error in the hot surface ignitor circuit.	<ol style="list-style-type: none"> 1. Check that all wiring is correct and secure. 2. Replace hot surface ignitor.
	System in lockout.	<ol style="list-style-type: none"> 1. Gas supply is off or too low to operate. 2. Hot surface ignitor not positioned correctly. 3. Low voltage to the water heater. 4. Electric polarity to unit is incorrect - test and correct.
	Problem in the gas valve driver circuit.	<ol style="list-style-type: none"> 1. Turn power to the water heater off for 10 seconds and then back on. 2. Replace gas control valve.
	Problem with the internal circuit.	<ol style="list-style-type: none"> 1. Turn power to the water heater off for 10 seconds and then back on. 2. Replace gas control valve.
	Problem with the internal circuit.	<ol style="list-style-type: none"> 1. Turn power to the water heater off for 10 seconds and then back on. 2. Replace gas control valve.
	Flame signal sensed out of proper sequence.	<ol style="list-style-type: none"> 1. Replace gas control valve.
	ECO activated.	<ol style="list-style-type: none"> 1. Replace gas control valve.
	One of the temperature adjust buttons stuck closed.	<ol style="list-style-type: none"> 1. Press and release each of the buttons once. 2. Replace gas control valve.
	Water temperature sensor is either open or short circuited.	<ol style="list-style-type: none"> 1. Check that all wiring is correct and secure. 2. Replace gas control valve.

WATER HEATER CONTROL

LIMITED RESIDENTIAL GAS WARRANTY

THIS WARRANTY IS APPLICABLE TO THE ORIGINAL OWNER ONLY. If the glass lined tank in this water heater shall prove upon examination by A. O. Smith Corporation (the warrantor) to have leaked during the warranty period in normal residential use, due to natural corrosion from potable water therein, the warrantor will furnish the ORIGINAL OWNER a replacement A. O. Smith water heater of equivalent size and current model, or a replacement part for any component part which fails in normal use, in accordance with the warranty terms and conditions specified below. THE A. O. SMITH REPLACEMENT MODEL OR PART WILL BE WARRANTED FOR ONLY THE UNEXPIRED PORTION OF THE ORIGINAL WARRANTY. The warranty period will be determined by the original installation date of the water heater. PROOF-OF-PURCHASE AND PROOF-OF-INSTALLATION ARE NECESSARY TO VALIDATE THIS WARRANTY. This warranty is not transferable and applies to models listed in Table 1 which are produced after December 31, 1996.

MODEL	WARRANTY PERIOD	PARTS ²
FPSH-175	TANK ¹ 6 YEARS	2 YEARS

When the water heater has been used for other than single family residential application: 1. The tank warranty shall be reduced to 1 year. 2. The parts warranty shall be reduced to one year for all models. Returned parts which meet any of the following conditions are not covered by this warranty: 1) improper installation or removal, 2) damaged by other than normal wear, 3) replaced for cosmetic purposes, or 4) returned with defaced date codes.

CONDITIONS AND EXCEPTIONS

This warranty shall apply only when the water heater is installed and operated in accordance with 1) all local fire codes and plumbing codes, ordinances and regulations, 2) the printed instructions provided with it, 3) good industry practices, and 4) proper safety practices such as but not limited to a properly sized drain pan if installed in an area where leakage from connections of the tank would result in damage to the area adjacent to the heater. In addition, a new temperature and pressure relief valve, certified by the American Gas Association must have been properly installed and piped to the nearest drain.

This warranty shall apply only when the heater is:

- owned by the original purchaser;
- used at temperatures not exceeding the maximum calibrated setting of its thermostat;
- not subjected to excessive water pressure fluctuations and not subject to an operating pressure greater than 150 P.S.I.;
- filled with potable water, free to circulate at all times and with the tank free of damaging water sediment or scale deposits;
- used in a non-corrosive and non-contaminated atmosphere;
- used with factory approved anode(s) installed;
- in its original installation location;
- in the United States, its territories or possessions, and Canada;
- sized in accordance with proper sizing techniques for residential water heaters;
- bearing a rating plate which has not been altered, defaced or removed except as required by the warrantor;
- used in an open system or in a closed system with a properly sized and installed thermal expansion tank;
- fired at the factory rated input using the fuel stated in the face of the rating plate;
- operated with the inner and outer combustion chamber doors in place;
- maintained in accordance with the instructions printed in the manual included with the heater.

Any accident to the water heater or any part thereof (including freezing, fire, floods, or lightning), any misuse, abuse or alteration of it, any operation of it in a modified form, or any attempt to repair tank leaks or parts, will void this warranty.

SERVICE AND LABOR RESPONSIBILITY

UNDER THIS LIMITED WARRANTY, THE WARRANTOR WILL PROVIDE ONLY A REPLACEMENT WATER HEATER OR PART THEREOF. THE OWNER IS RESPONSIBLE FOR ALL OTHER COSTS. Such costs may include but are not limited to:

- a. Labor charges for service, removal, or reinstallation of the water heater or part thereof.

- b. Shipping and delivery charges for forwarding the new water heater or replacement part from the nearest distributor and returning the claimed defective heater or part to such distributor except in the state of California where such charges are the manufacturer's responsibility.
- c. All cost necessary or incidental for handling and administrative charges, and for any materials and/or permits required for installation of the replacement heater or part.

LIMITATION ON IMPLIED WARRANTIES

Implied warranties, including any warranty of merchantability imposed on the sale of this heater under state law are limited to one year duration for the heater or any of its parts. Some states do not allow limitations on how long an implied warranty lasts, so the above limitations may not apply to you.

CLAIM PROCEDURE

Any claim under this warranty should be initiated with the dealer who sold the heater, or with any other dealer handling the warrantor's products. If this is not practical, the owner should contact: A. O. Smith Water Products Company, 5621 West 115th Street, Alsip, Illinois, 60803 (800) 323-2636. Canadian customers should contact A. O. Smith Enterprises, Ltd., P.O. Box 310-768 Erie Street, Stratford, Ontario N5A 6T3, (800) 265-8520.

The warrantor will only honor replacement with identical or similar water heater or parts thereof which are manufactured or distributed by the warrantor.

Dealer replacements are made subject to in-warranty validation by warrantor.

PROOF-OF-PURCHASE AND PROOF-OF-INSTALLATION DATES ARE REQUIRED TO SUPPORT WARRANTY FOR CLAIM FROM ORIGINAL OWNER. THIS FORM DOES NOT CONSTITUTE PROOF-OF-PURCHASE OR PROOF-OF-INSTALLATION.

DISCLAIMERS

NO EXPRESS WARRANTY HAS BEEN OR WILL BE MADE IN BEHALF OF THE WARRANTOR WITH RESPECT TO THE MERCHANTABILITY OF THE HEATER OR THE INSTALLATION, OPERATION, REPAIR OR REPLACEMENT OF THE HEATER OR PARTS. THE WARRANTOR SHALL NOT BE RESPONSIBLE FOR WATER DAMAGE, LOSS OF USE OF THE UNIT, INCONVENIENCE, LOSS OR DAMAGE TO PERSONAL PROPERTY, OR OTHER CONSEQUENTIAL DAMAGE. THE WARRANTOR SHALL NOT BE LIABLE BY VIRTUE OF THIS WARRANTY OR OTHERWISE FOR DAMAGE TO ANY PERSONS OR PROPERTY, WHETHER DIRECT OR INDIRECT, AND WHETHER ARISING IN CONTRACT OR IN TORT.

Some states do not allow the limitation or exclusion of incidental or consequential damages, so the above limitation or exclusion may not apply to you.

This warranty gives you specific legal rights, and you may also have other rights which vary from state to state.

Fill out and keep with water heater.

IMPORTANT INFORMATION	
Model Number	_____
Serial Number	_____
Installation Information:	
Date Installed	_____
Company's Name	_____
Street or P.O. Box	_____
City, State, and Zip Code	_____
Phone Number	_____
Plumber's Name	_____



A.O. SMITH
WATER PRODUCTS
COMPANY

Alsip, IL

A.O. SMITH WATER PRODUCTS CO., INC.
5621 W. 115TH STREET • ALSIP, ILLINOIS 60803
PHONE: 1-800-433-2545 • FAX: 1-800-433-2515
www.hotwater.com • E-MAIL: parts@hotwater.com